

AccuLazr™ AL5010

Laser Bar Code Scanning Solutions

Product Line Manual



AccuLazr™ AL5010 Product Line Manual

PN 1000068393 2.0 | CMS 11-0023 | 2012.03.25 | LSM-RAY

Document Revision Control

This document is under revision control in accordance with Accu-Sort's Quality System. Any addenda or other documents associated with this manual are under separate revision controls. A revision number is changed by 0.1 whenever technical information is changed or added to a document.

Copyright Information

Copyright © 2011-2012 ACCU-SORT® SYSTEMS, INC. All rights reserved.

No part of this document is to be reproduced or utilized in any form or by any means, electronic or mechanical, including photocopying, recording, or by an information storage and retrieval system without prior written consent of Accu-Sort Systems, Inc. All drawings and specifications contained in this manual are the property of Accu-Sort Systems, Inc. and shall not be reproduced, copied or used in whole or in part as the basis for the sale or manufacture of products without the written permission.

Accu-Sort® and DRX® are registered trademarks and the AS logotype, AccuLazr™ and 1-800-BAR-CODE™ are trademarks of Accu-Sort® Systems, Inc.

All other company or product names are mentioned for purposes of identification only, and may be trademarks of their respective owners.

Disclaimer Information

The information contained in this manual is subject to change without notice. Supplemental information or documentation may be required for certain applications or usage.

The examples and diagrams in this manual are included solely for illustrative purposes. Because of the many variables and requirements associated with any particular installation, Accu-Sort cannot assume responsibility or liability for actual use based on the examples and diagrams.

No patent liability is assumed by Accu-Sort with respect to use of information, circuits, equipment, or software described in this manual.

In no event will ACCU-SORT® SYSTEMS, INC. be responsible or liable for indirect or consequential damages resulting from the use or application of this equipment.

Contents

Preface

Intended Audience	vii
Thank You.....	vii
Overview of Contents.....	viii
Other Sources of Information.....	viii
Conventions	viii
Customer Service	viii

1 Introduction

AL5010 Product Line Overview	9
The AL5010 Scan Head	10
The AL5010 Mounting Base	10
The AL5010 Interface Module	11
AccuLazr™ User Interface.....	12
Typical AL5010 Mid-Range Bar Code Reading Applications.....	13
Options and Accessories	14

2 Safety

Symbols	15
General Precautions	16
Unpacking, Mounting and Installation Recommendations	16
Compliance Requirements	17
Electrical Safety	17
Electrical Grounding Requirements.....	18
Electrostatic Discharge	18
Basic Rules for ESD Control.....	18
Laser Safety.....	19
Safety Labels and Locations.....	20

3 Mechanical Installation

Prerequisites	21
Tools Required.....	21
Additional Information	21
Unpacking Instructions	21
Installation Sequence.....	22
Orientation Considerations	23
Read Range.....	23
Bar Code Orientation to Scanning Area	24
General Mounting Guidelines	25
Reader Positioning.....	25
Dimensions and Clearances.....	26
Attaching the Mounting Base.....	26
Attaching the Universal Mounting Bracket (UMB)	27
Installing an AL5010 Scan Head	28
Mounting the Trigger Photoeye	29
Mounting the Tachometer.....	30
Mounting the Interface Module	31
Mounting the I/O Modules.....	34

4 Electrical Installation

Prerequisites	37
Tools Required.....	37
Additional Information	37
Installation Sequence(s)	38
Installing Multiple Readers.....	38
General Electrical Installation Guidelines and Precautions.....	39
Cable and Conduit Connections	40
Wiring the AL5010 Interface Modules.....	41
Power Requirements	45
Power Supply Connections.....	45
Trigger Connections.....	46
Tachometer Connections.....	47
Serial Communications Connections (COM1 and COM2)	48
Ethernet Communications Connections	50
I/O Module Connections	51
DeviceNet	53
Profibus	53
Connecting the AL5010	53
Wiring to the AL5010 without an Interface Module.....	54
Check Installation.....	55

5 Setup

Getting Started	57
AccuLazr User Interface Basics.....	60
Getting Help	60
Modify Settings	61
Configuration	62
Bar Codes.....	63
Modulo Checks.....	65
Stripping/Padding	66
Match Codes	67
Serial Communications	68
Network	71
Trigger	74
Relay	75
Tracking.....	76
FAST Monitor™	77
Advanced.....	79
Save / Retrieve	80
Diagnostics	81
Monitor.....	82
Log Viewer.....	83
Update Firmware.....	90

6 Operations

First-time Startup	91
Default Parameters	91
First-time Setup.....	92
Check Operations using Test Mode	92
Operations Checklist.....	93
Control Panel Indicators	94
Backup / Restore Procedures.....	99
Checking Operations with User Interface	100

Standalone Operation	102
Tracking Operation	103
Dual X-Scanning Operation	104
Multiple-Reader Network Operation	105
Scanning Array / Tunnel Operation	106

7 Maintenance

Laser Shutoff Procedure	107
Maintenance Tasks	108
Cleaning Exit Window	109
Cleaning Trigger Photoeye	110
Cleaning Tachometer	110
Tighten Mounting Hardware	111
Checking Interface Module Connections	111
Verify Reader Operation	112
Verify Photoeye Operation	112
Verify Tachometer Operation	112

8 Troubleshooting

Test Mode	113
Status Indicators	113
Control Panel Indicators	114
Diagnostics	117
Log Viewer	120
Update Firmware	126
Troubleshooting Tables	131

9 Service

Replacement Procedures	129
AL5010 Field Replaceable Units (FRUs) Spare Parts	130
Interface Module FRU Spare Parts	131

Appendices

A Specifications

AL5010 Technical Specifications	133
Basic Interface Module Technical Specifications	133
Enhanced Interface Module Technical Specifications	134
Power Supply	134
Output Modules	135
Input Modules	135
Certifications	136

B Read Charts

AL5010 Read Charts	137
--------------------------	-----

C User Interface

AccuLazr User Interface	149
Modify Settings	150
Configuration	151

Bar Codes.....	153
Modulo Checks.....	155
Stripping/Padding	156
Match Code Patterns.....	157
Serial Communications	161
Network	166
Trigger	170
Relay	172
Tracking.....	174
FAST Monitor™	176
Advanced.....	177
Save / Retrieve	179
Diagnostics	181
Monitor.....	182
Log Viewer.....	184
Update Firmware.....	185
D Networking Guide	187
E FAST Monitor Configuration	207
F Installation Drawings	209
G Test Label for Adjustable Raster Setup	231

Preface

Welcome to the **AccuLazr™ AL5010 Product Line Manual** from Accu-Sort Systems, Inc. This user manual includes the information you need to integrate effectively the **AL5010 Bar Code Reader** with your application. It contains detailed information about the following:

- Product features, capabilities, specifications and accessories
- Safety information
- Installation guidelines and procedures
- Configuring the AL5010 for your application
- Maintenance and Troubleshooting

This preface explains how this user manual is organized and introduces other sources of information that you will find useful.

Intended Audience

You should have a basic understanding of bar code scanning. Equipment installers must be familiar with standard wiring techniques and terminology. Because the AccuLazr user interface software runs on a web browser in the Microsoft® Windows® environment, you should know how to use a mouse, choose commands, and work with windows and dialog boxes.

This manual contains some terms that may be unfamiliar. Use the glossary at the back of this manual for assistance.

Thank You

Thank you for using an AL5010 bar code scanning solution and this manual.

We value your comments and feedback. Feel free to let us know what you like or dislike about AL5010 (or this manual) by e-mailing us at *info@accusort.com*.

You can also mail your comments to our corporate headquarters address or call us directly at 1-800-BAR-CODE™ or (215) 723-0981.



NOTE: There may be additional material that was not available when this product manual was produced. To learn if there is a documentation update, go to our web site's corresponding product page at www.accusort.com.

Other Sources of Information

You can choose from many information sources, including documentation, training, and support services, to increase your knowledge and understanding of the AL5010 bar code scanning solutions. If this manual refers you to other documentation, use only the latest versions unless otherwise specified.

Conventions



WARNINGS or CAUTIONS: This symbol identifies a hazard or procedure that, if incorrectly performed, could cause personal injury or result in equipment damage. It is also used to bring the user's attention to details that are considered IMPORTANT.



HIGH VOLTAGE CAUTION: This symbol alerts the user they are about to perform an action involving, either a dangerous level of voltage, or to warn against an action that could result in damage to devices or electrical shock.



LASER CAUTION: This symbol alerts the user they are about to perform an action involving possible exposure to laser light radiation.



ESD CAUTION: This symbol identifies a procedure that requires you take measures to prevent Electrostatic Discharge (ESD) e.g., use an ESD wrist strap. Circuit boards are most at risk. Please follow ESD procedures.



NOTES: This symbol draws attention to details or procedures that may be useful in improving, maintaining, or enhancing the performance of the hardware or software being discussed.

NOTE REGARDING DIMENSIONAL REFERENCES: This manual provides all dimensional references in inches and in most cases Metric referenced in brackets, for example 10 inches [254 mm].

Customer Service

Training

Accu-Sort Systems offers a complete set of training courses to help you and your staff get the most out of your investment. We can help you develop a training plan that provides thorough training for both your project team and your end users. We will work with you to organize courses appropriate to your job or area of responsibility. Training professionals can show you how to plan your training throughout the implementation process so that the right amount of information is delivered to key people when they need it the most. You can attend courses at our training center, or you can arrange for our trainers to teach at your facility. In addition, we can tailor standard courses or develop custom courses to meet your needs.

Support

From on-site support to central support, our team of experienced professionals provides the help and information you need to keep your equipment working for you. This team includes your Account Manager and Accu-Sort's large staff of support specialists with expertise in your business area and managing your hardware and software environment.



NOTE: If you have any problems or questions that require Accu-Sort's assistance, direct your calls to **Customer Service** at 1-800-BAR-CODE™ or (215) 723-0981.

1 Introduction

This chapter presents an introductory description of the **AccuLazr™ AL5010** laser barcode scanner product line including:

- AL5010 Product Line Overview
- AccuLazr User Interface

AL5010 Product Line Overview

The AL5010 line of laser barcode readers is designed with industrial and manufacturing applications in mind, providing high-speed scanning and high reliability in a rugged industrial enclosure. The entire AL5010 product line offers a large depth of field that provides accurate barcode reading from as little as 4 inches up to 48 inches.

The AccuLazr AL5010 Mid-Range Laser Barcode Readers include:

- AL5010 Scan Head
- AL5010 Mounting Base
- AccuLazr Interface Module (optional)
- Power Supply Module (optional)



AL5010 Barcode Reader

AccuLazr Basic Interface Module

AL5010 Scan Head

The AL5010 Scan Head incorporates the optics and laser module(s) for scanning barcodes as well as the decoding engine and parameter storage module. The control panel provides several LED status indicators and three function buttons.

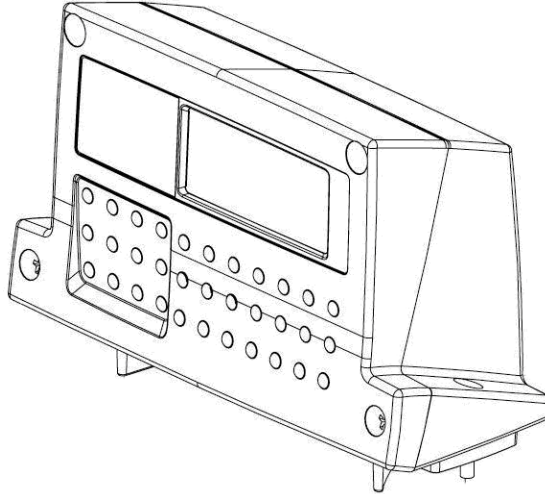

There are five models of the **AL5010 Scan Head** (each available with optional adjustable raster):

- One-laser models for standard and high-density
- Two-laser models for standard, near-focus high-density and high-density

An optional **Adjustable Raster** (adjustable up to 20-degrees above or below 0-degrees, variable DOF) is available in the existing scan head housing. **No bolt-on additions are required.**

AL5010 Mounting Base

The AL5010 Mounting Base provides for the mounting of the AL5010 as well as the wiring interface between the scan head and AccuLazr Interface Module. It includes a parameter storage module that enables parameters to be uploaded/downloaded with the 'hot-swappable' scan head.

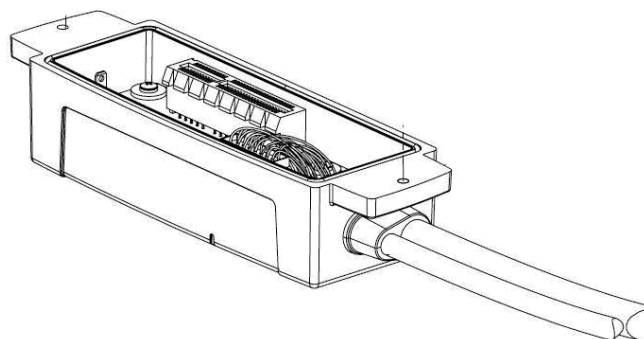

AccuLazr Interface Module

The AccuLazr Interface Module is fully compatible with the AL5010 line of barcode readers and is available in both a Basic and Enhanced version.

The AccuLazr **Basic Interface Module** provides the following connections:

- Scanner (15-pin and RJ45)
- Ethernet / EtherNet/IP (1)
- Serial ports (2)
- Trigger Input
- Power



The **Enhanced Interface Module** provides the following additional connections:

- Tach Input
- Up to four Opto22 I/O modules
- Fieldbus communications (either DeviceNet or Profibus)



AccuLazr™ User Interface

The AccuLazr User Interface lets you configure an AL5010 through a series of intuitive, user-friendly menus, tools and dialog boxes accessed via a web browser. Context sensitive help is available to assist with use of the software.

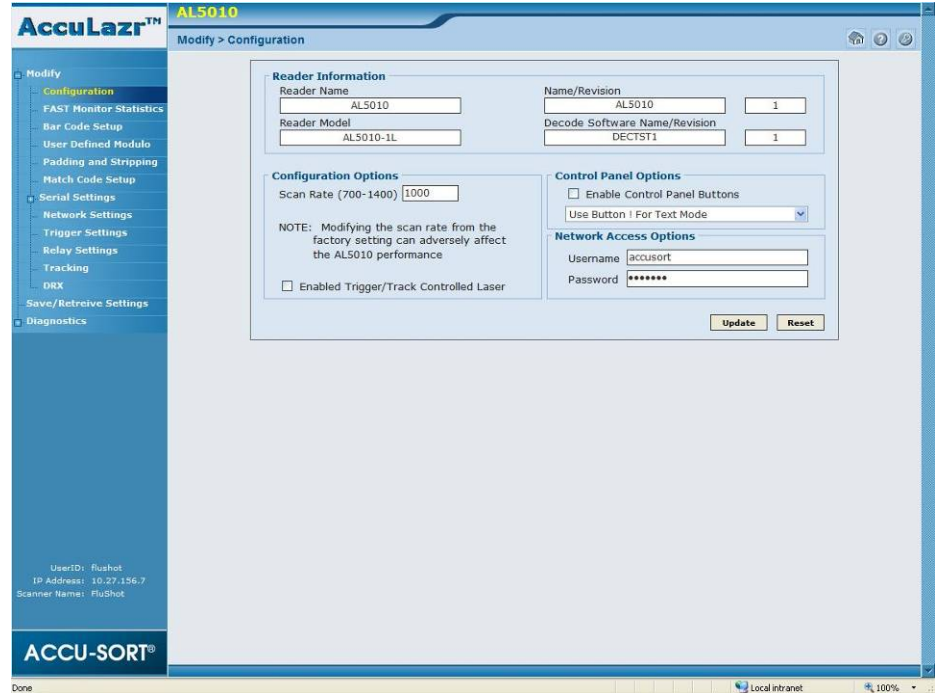

With the user interface, you can:

- Integrate AL5010 to your system and application without custom software.
- Modify output messages to accommodate your system needs.
- Add or modify the barcode symbologies read by AL5010.
- Define up to four (4) relay input/outputs.
- Monitor AL5010 performance using diagnostic tools.
- Fine-tune optional adjustable raster.

You can easily configure your AL5010 reader by using a desktop or laptop computer, an Ethernet network connection and the browser-based interface.

Typical AL5010 Mid-Range Barcode Reading Applications

Use the AL5010 in the following applications:

- single-reader applications (side or top)
- pick module scanning
- multi-sided scanning
- retail distribution centers
- industrial manufacturing

With optional Adjustable Raster:

- pallet scanning
- hard-to-read barcodes
- plastic shrink-wrapped barcodes
- unknown label positioning

Options and Accessories

Contact your sales representative for assistance in determining which options and accessories will be applicable to your application.

If you know which items are needed, contact *Accu-Sort's Customer Service Department* (ask for the *Spare Parts Coordinator*) between 8 AM and 4:30PM (EST) Monday through Friday at 1-800-BAR-CODE (Fax: 215-723-1515).

2 Safety

Please follow the safety precautions and warnings found in this manual when installing, setting up, operating, maintaining, troubleshooting or replacing any Accu-Sort products, parts, or related equipment. Following these precautions will prevent personal injury or damage to the unit. Failure to follow these precautions may also void your warranty.

This section provides important information regarding safety and your AL5010, especially involving issues regarding:

- General Precautions during Mounting and Installation
- Compliance Requirements
- Electrical Safety
- Electrical Grounding Requirements
- Electrostatic Discharge Precautions and Control
- Laser Safety

Contact Accu-Sort at 1-800-BAR-CODE™ if you need more information.

Symbols

Throughout this manual, special safety alerts are indicated by the following symbols:



WARNINGS or CAUTIONS: This symbol identifies a hazard or procedure that, if incorrectly performed, could cause personal injury or result in equipment damage.



HIGH VOLTAGE CAUTION: This symbol alerts the user they are about to perform an action involving, either a dangerous level of voltage, or to warn against an action that could result in damage to devices or electrical shock.



LASER CAUTION: This symbol alerts the user they are about to perform an action involving possible exposure to laser light radiation.



ESD CAUTION: This symbol identifies a procedure that requires you take measures to prevent Electrostatic Discharge (ESD) e.g., use an ESD wrist strap. Circuit boards are most at risk. Please follow ESD procedures.

Alerts help you to:

- Identify a hazard and its consequences
- Avoid a hazard by taking adequate safety precautions
- Get the most out of your bar code solution

General Precautions

Installation and Service by Qualified Service Technician Only



WARNING: All procedures involving exposure to the inside of the AL5010 Interface Module must be performed by a trained technician because of possible exposure to emitted laser radiation, high voltage, and could reduce the effectiveness of the device's IP rating. There are no user-serviceable parts inside. Do not attempt to open the unit or perform any installation/service procedures unless you are a trained technician! **DO NOT REMOVE** the faceplate from the scan head enclosure. Opening the AL5010 will void the factory warranty.

Refer all servicing and advanced troubleshooting to a qualified service technician. Technical training is available from Accu-Sort Systems.

Furthermore, even trained technicians should always reference the specific product documentation for more detailed service procedures that may not be described in the *AL5010 Product Manual*.

Unpacking, Mounting and Installation Recommendations



CAUTION: Firmly fasten mounting structures in place before installing the equipment to any mounting structure. Avoid using freestanding mounting structures. If your application requires a freestanding mounting structure, avoid making the structure top-heavy.

- Follow all procedures regarding electrical safety, laser safety, and electrostatic discharge safety (ESD) as outlined in this manual.
- Save all packing material in case you have to transport your readers.
- Use steel or aluminum as a mounting structure. An Accu-Sort mounting structure is recommended for optimum system performance.
- Check mounting hardware periodically for tightness and stability.
- Do not use sheet rock, plaster board, wood, or other unstable mounting surfaces.
- Do not use mounting surfaces that are subject to high vibrations.
- Do not create any obstructions of airflow around the modules. Keep the area around the modules clean to provide for cooling. (Refer to specific product manuals for minimum clearances.)
- Avoid dropping the readers during unpacking and installation.
- Do not touch the window glass of the scan head.

Compliance Requirements



FCC NOTICE: The AL5010 has been tested and found to comply with the limits for a Class A digital device, pursuant to *Title 47, Part 15 of the FCC Rules*. These limits are designed to provide a reasonable protection against harmful interference when the equipment is operated in a commercial environment. This equipment generates, uses, and can radiate radio frequency energy and, if not installed and used in accordance with the instruction manuals, may cause harmful interference to radio communications. Operation of this equipment in a residential area is likely to cause harmful interference in which case the user will be required to correct the interference at his own expense.



WARNING: These are Class A products. In a domestic environment, these products can cause radio interference, in which case the user may be required to take adequate measures. (Ref. CISPR 22 = EN 55 022:1995.)



IMPORTANT: Follow the guidelines below to maintain Electromagnetic Compatibility (EMC) Compliance:

- Interconnecting cables must be twisted pair cables.
- All shielded I/O cables shall have the shield terminated to the chassis.
- **NOTE: DRAIN WIRE SHIELDING IS NOT ADEQUATE.**
- Do not remove the shielding covers.
- Refer to the details on making custom cables as provided in the specific technical manual for the component.

Electrical Safety

AL5010 must be installed in accordance with Canadian Electrical Code, Part I, CSA C22.1; CSA C22.2 No. 0; and the National Electrical Code, NFPA 70. For complete requirements, National Electrical Code, ANSI/NFPA 70, Canadian Electrical Code, Part I, C22.1, or other national standard must be consulted.

- For PERMANENTLY CONNECTED EQUIPMENT/RACK MOUNTED, incorporate a readily accessible disconnect device in the fixed wiring.
- For PLUGGABLE EQUIPMENT/RACK MOUNTED, install the socket-outlet near the equipment so it is easily accessible.
- Make sure that all personnel who work with the equipment know where the disconnect switches or circuit breakers are located.
- Before performing any type of maintenance, turn off power to the unit and disconnect the power cord.
- Be certain your hands and the floor of your work area are dry before touching electrical equipment or connecting cords.
- Routinely check all power cords, plugs, wiring, and cable connections for any signs of exposed wire or deteriorating insulation. If you notice any damage, make arrangements with service personnel to repair or replace the damaged item immediately.

Electrical Grounding Requirements

Before applying power to any device, ALL components MUST be electrically grounded. Follow these precautions:

- Ensure all AC power outlets have a properly grounded receptacle.
- ALL components MUST be properly cabled and grounded with three-conductor AC power cords.
- Use the correct power cord for your country.
- Reference specific grounding instructions for each component.
- Do not use a two-prong adapter.
- Do not cut/remove the round grounding prong from any plug.
- Do not use an extension cord to defeat any ground.

Electrostatic Discharge



ESD CAUTION: Measures must be taken to prevent Electrostatic Discharge (ESD) at all times when handling any product, equipment, unit or part (e.g. use a grounded ESD wrist strap). It should be noted that circuit boards are at greatest risk to damage from ESD. Please follow standard ESD precautions!

Electrostatic discharge (ESD), the transfer of static electricity from one object to another, is an often-unnoticeable hazard to electronic components. Boards and other devices with integrated circuits are particularly sensitive to ESD damage. Product failures may not occur until days or weeks after the component was damaged.

Static damage to units can take the form of upset failures or catastrophic failures (direct and latent).

An upset failure occurs when an electrostatic discharge is not significant enough to cause total failure, but may result in intermittent gate leakage, causing loss of software or incorrect storage of information.

Direct catastrophic failures occur when a unit is damaged to the point where it is permanently damaged.

Basic Rules for ESD Control

Below are some keys to effectively control unnecessary ESD damage when working with ESD-sensitive devices:

- Define an ESD protective area and work on the ESD-sensitive devices in this area only.
- Define static sensitivity of devices to be handled in ESD protective area.
- Establish suitable static control program that limits static generation to less than the damage threshold of the most sensitive device and provides a safe, defined path for static charge dissipation.
- Prevent contamination of the protective area by unnecessary non-static controlled materials.
- Audit the ESD protective area regularly to ensure that static control is maintained. Document the findings for future reference.

- Refer to the specific ESD precautions for each component.

Laser Safety

The AL5010 uses visible laser diodes and emits a “moving” red beam. Do not stare into the AL5010’s exit window at the laser light source. Avoid unintentional exposure to laser light whenever possible. The laser light level does not constitute a health hazard, however staring at the laser light for prolonged periods could result in eye damage.

The following appears next to the AL5010 laser exit window:

WARNING! LASER LIGHT EMITTED FROM THIS APERTURE



Warning on AL5010 Laser Exit Window to Avoid Exposure



WARNING: Use of controls, adjustments, or procedures other than those specified in this document may result in hazardous laser light exposure.

The **AL5010 Line Scanning Bar Code Reader** is rated as a **Class 1** Laser Product by the International Electrotechnical Commission. Compliances are as follows: Class 1 Laser Product (IEC-60825-1) 2007.

Before performing any maintenance or service procedures, perform the laser shutoff procedure provided in Chapter 7.

Safety Labels and Locations

Refer to the following figures for specific label locations and warnings. When operating, repairing, or replacing an AL5010, note all label content on the unit. These labels provide special precautions for operation, usage specifications, product identification, and service information.



WARNING: LASER LIGHT EMITTED FROM THIS APERTURE.



Label Placement AL5010 Scan Head

3 Mechanical Installation



IMPORTANT: The AL5010 contains electronics that may be affected by electrostatic discharge (ESD). To prevent personal injury or damage to the unit, please follow the safety precautions and warnings found in *Chapter 2*. Failure to follow these precautions may void your warranty.



WARNING: *There are no user serviceable parts inside the AL5010.* No internal components of the AL5010 are field replaceable units (FRUs). Opening the unit will potentially expose the user to emitted laser radiation, high voltage, and could reduce the effectiveness of the device's IP rating. **DO NOT REMOVE** the faceplate from the scan head enclosure. Opening the AL5010 will also void the factory warranty.

Prerequisites

- Read all instructions before beginning your installation.
- Define and confirm the accuracy of your application's requirements.
- Review all installation-specific drawings.
- Review and plan the mechanical installation of all devices used in your application. Be sure to allow adequate clearance for maintenance.
- Review and plan the power requirements for your application.
- Check the contents of the shipping cartons against the packing list.
- Record all product serial numbers.

Tools Required

- 5/32" Allen Wrench
- 10mm Nut Driver or box wrench
- Phillips Screw Driver (1 x 80 [#1])
- Tape Measure
- Pencil or Marker

Additional Information

See also: **Quick Reference Guides** for Installation

- AL5010 with Basic Interface Module (1000070256)
- AL5010 with Enhanced Interface Module (1000070257)
- Establishing A Connection to the User Interface (1000070258)

These guides are available online at:

http://www.accusort.com/en/about/regform_downloads_al5010.php

Unpacking Instructions



IMPORTANT: The AL5010 packaging is designed to protect the unit(s) during shipment. Do not throw it away. Save all packing material in case you need to transport your unit(s).

Installation Sequence



NOTE: Everything should be MECHANICALLY INSTALLED before performing any ELECTRICAL INSTALLATION. Reference *Chapter 4* for electrical installation details.

Installing a Single Unit

To install a single unit, follow this sequence of steps:

- **Complete mechanical installation.**
 - Review the details of your application's requirements.
 - Determine and mark the reader mounting location.
 - Erect mounting frame or other supporting structures.
 - Attach the Universal Mounting Bracket (UMB) to the frame. (UMB and mounting frame options are available from Accu-Sort.)
 - Install the mounting base to the UMB (or frame, if UMB not used).
 - Mount the AccuLazr Basic or Enhanced Interface Module to structure.
 - Mount the Accu-Sort power supply to structure.
 - Mount Trigger Photoeye (optional).
 - Mount tachometer (Enhanced Interface Module only).
- **Complete electrical installation.**
 - Install the scan head to the mounting base and wire interface module. (See *Chapter 4*.)



NOTE: To reduce the possibility of damage to the scan head, install it after the mounting base is mounted, wired, and all wiring checked for accuracy.

- **Setup your reader.**
 - See Chapter 5.
- **Check operations.**
 - See Chapter 6.

Installing multiple units

To mechanically install multiple units, follow the same sequence of steps, per reader, as defined in *Installing a Single Unit*. Your application will define how the mounting requirements vary for each reader.

Multiple-reader networks may require a different approach to physical location of the power source, trigger photoeye, and tachometer since they are most likely being shared by the group of readers.

Orientation Considerations

Consider the important factors that affect how the reader is oriented in respect to the barcoded packages (products) and their method of conveyance.

Mounting the reader for optimum performance depends on these factors:

- **Read Range** defining the distance (and variations) between the reader and packages, including the near/far distances, and overall depth of field
- **Barcode Orientation** on products (ladder or picket fence) as well as the angle in which codes will appear (skew, pitch and tilt)
- **Reader Positioning** for type of scanning required to accommodate picket fence or ladder barcode orientation (yaw, pitch and roll angles)

Read Range

The AL5010 must be positioned in the scanning area to accommodate reading products over a read range specific to your application. Use the following diagram to determine the near/optimum/far read distances. These dimensions result in the overall depth of field your application requires.

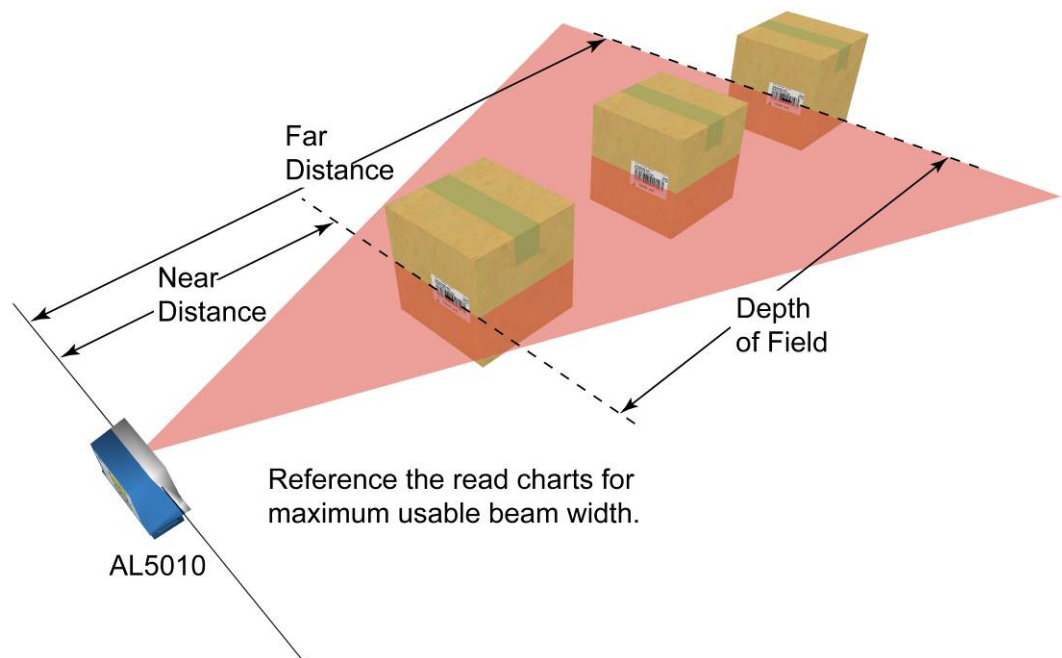

Barcode Orientation to Scanning Area

Picket Fence or Ladder Orientation Barcode placement usually determines the AL5010's positioning. The AL5010 can be mounted to read codes in either a ladder or picket fence orientation.

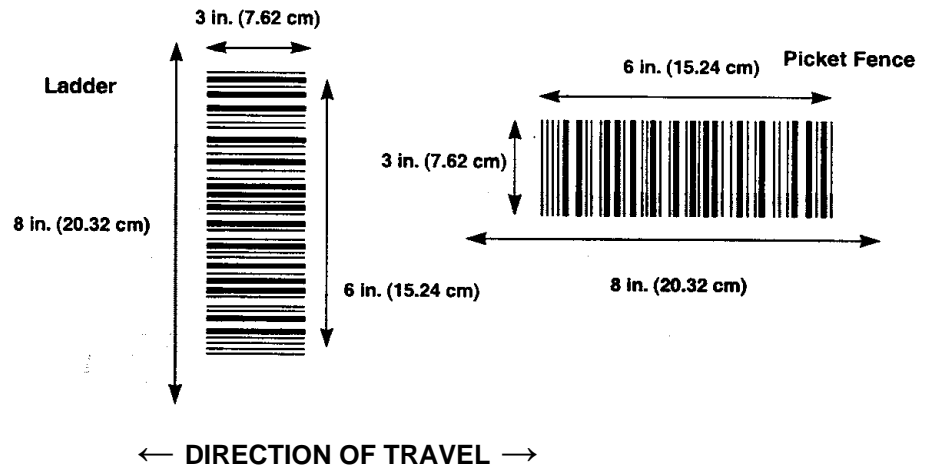

Picket Fence and Ladder Orientation Illustrated

Barcode Skew, Pitch and Tilt These angles affect barcode readability. Barcodes pitched or skewed up to 45 degrees are still readable. Although some skew may occur, it should not exceed 45 degrees.

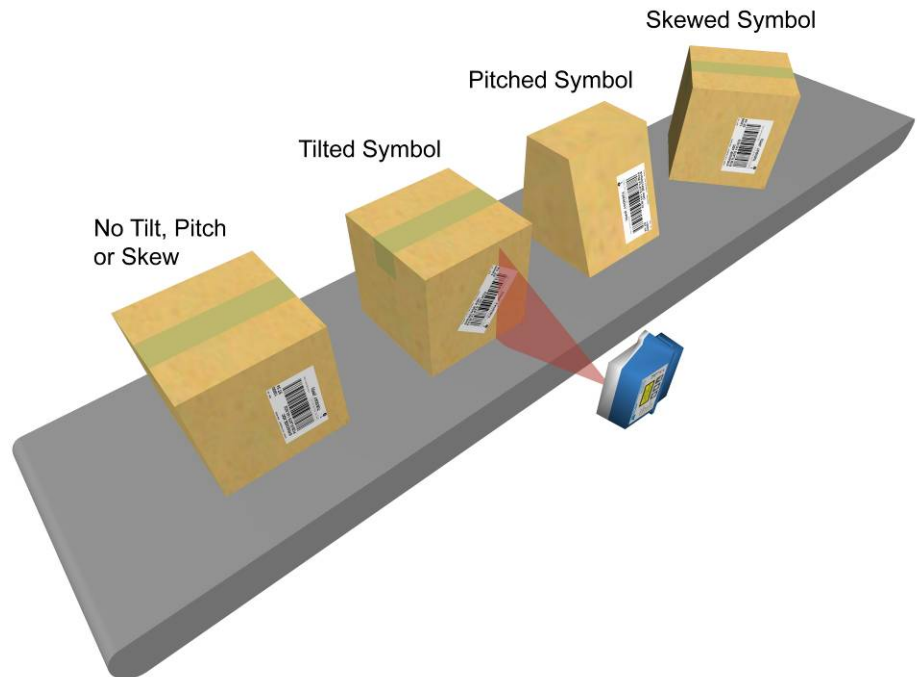

General Mounting Guidelines

As you plan and install the AL5010 barcode solution for your application, be sure to keep the following mounting guidelines in mind:

- Determine the proper orientation and position of the reader.
- Leave adequate clearances for maintenance and wiring.
 - AL5010 Reader: ~ 1-inch [25 mm]
Required for scan head removal from mounting base.
 - Interface Modules: ~ 8-12 inches [203-305 mm]
- Plan mechanical installation based on the application's electrical requirements. See *General Electrical Installation Guidelines in Chapter 4*.

It is important that you follow all safety precautions when installing, setting up, operating, maintaining, troubleshooting or replacing any Accu-Sort products, parts or related equipment. See *Chapter 2, Safety*.

Reader Positioning: Fixed Laser



IMPORTANT: The AL5010 is able to decode barcodes at a variety of angles; however significant angular distortion may degrade reading performance. When positioning the reader, remember that the scan beam exits the scan window parallel to the mounting base.

- When mounting the AL5010, take into consideration your application's barcode orientation.
- Mount the reader so that the scan beams will intersect barcodes.

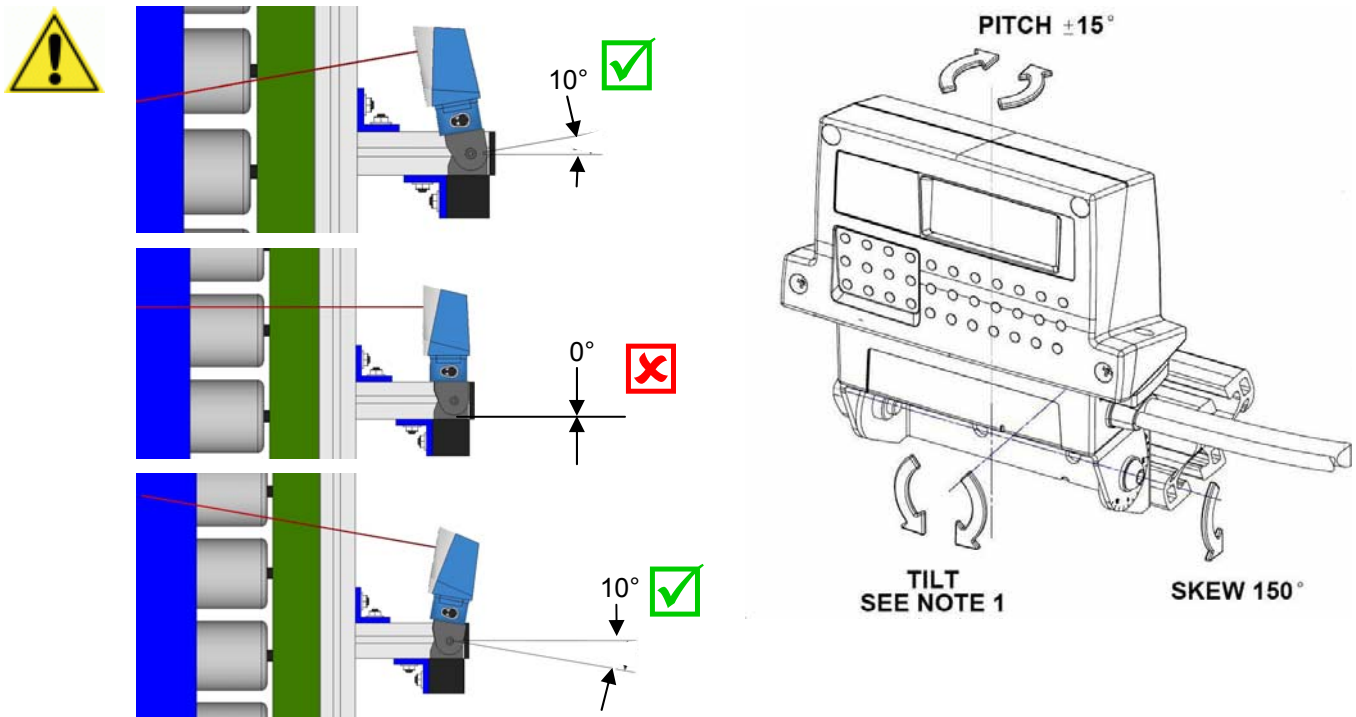

IMPORTANT: To avoid the laser reflecting back onto itself and lowering performance, install at a 10-degree skew.

AL5010's Range of Motion with Universal Mounting Bracket (UMB)

Reader Positioning: Adjustable Raster

The Adjustable Raster version (sometimes referred to as “vibrating vein”) of the AL5010 uses an additional mirror that oscillates to throw the laser over a configurable area. This extra functionality has all been engineered into the original AL5010 housing. As the mirror oscillates, the scan line sweeps across the target surface in application where greater coverage is needed. Specifically, the AL5010 Adjustable Raster can be configured to sweep up to 20-degrees above or below zero. When an AL5010 with the adjustable raster feature is installed, the user interface will include a **Raster** setup screen (see *chapter 5 Setup*).



The adjustable raster is ideal for pallet scanning or other applications when the position of the barcode is variable, but scan rate (scans/second) is decreased because of the oscillation of the mirror. The sweep of the raster and scanner skew angle is adjusted to get the best coverage over the probable scan area.

Raster Setup

The Adjustable Raster version of the AccuLazr™ AL5010 Laser barcode scanner requires some extra care during installation. The procedures below will help achieve the coverage needed for your application while ensuring the maximum read rate.

AL5010 Adjustable Raster Installation

Mount the Scanner

1. Mount the scanner according to specifications.
2. Tilt the scanner back at a 15-degree angle.

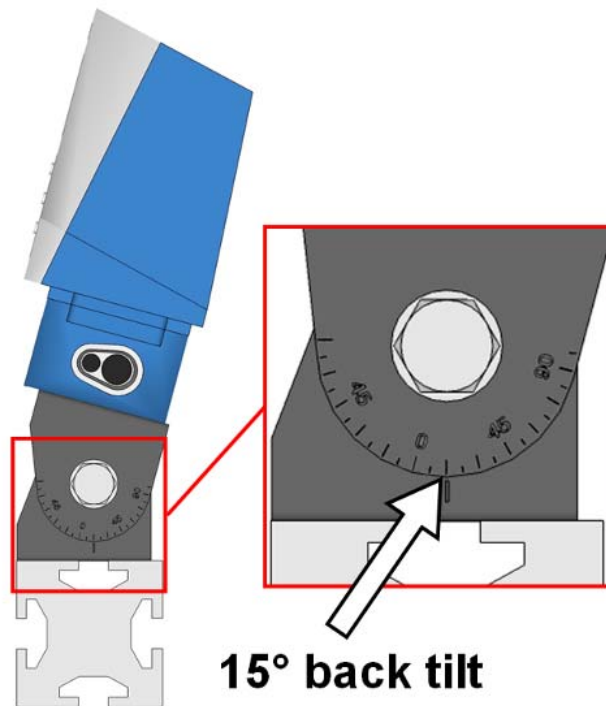

Set Up the Raster Sweep

1. Start the user interface (See chapter 5, Setup).
2. In **Modify Settings > Barcode**, select Code 128. The test barcode label is a 12 character, code 128.
3. Print out or photo copy the barcode test label sheet found at the end of this appendix.
4. Place the barcode test labels on a test box.

5. Position box at nearest read distance to the scanner.



6. Identify the highest and lowest code placement on the side of a box in your system. Mark the highest and lowest code positions on the test box.



7. In the user interface, navigate to **Modify Settings > Raster**.
8. Type -20 in the Upper Sweep and Lower Sweep text fields.

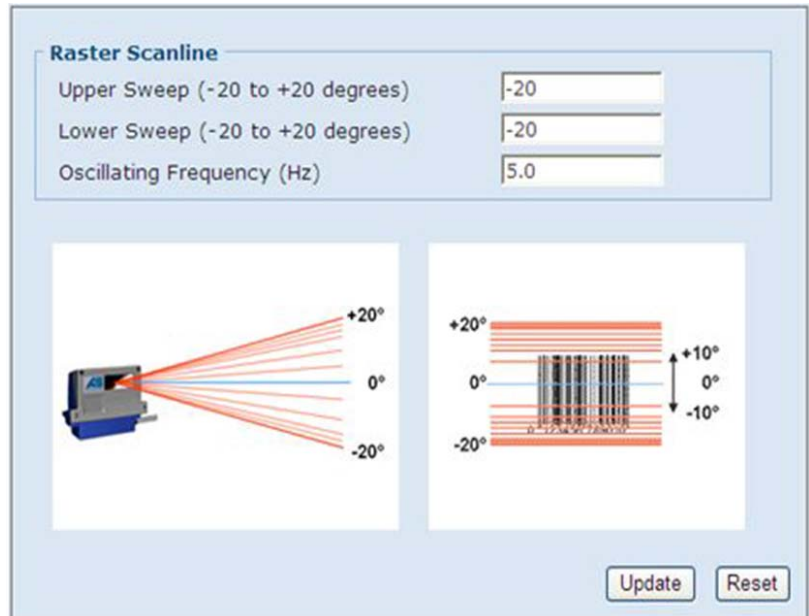

NOTE: This will stop the raster from sweeping and lock it in position at the -20 degrees.

9. Adjust the height of the scanner, so that at -20-degrees, the scan line is aligned with the lowest barcode mark on the test box.

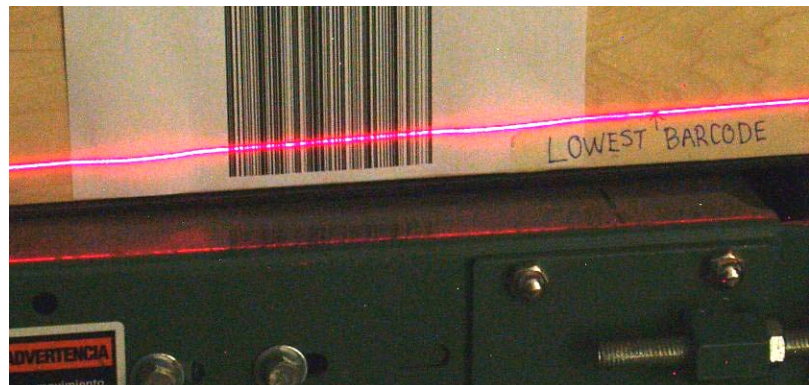

10. With the laser line intersecting the barcode, put the scanner into test mode using the user interface. To do this, navigate to **Diagnostics > Monitor**.
11. On the **Monitor** screen, click **Start Test Mode**.
12. Check the read quality on the monitor. The quality should be 100%.

- In **Modify Settings > Raster**, gradually increment your upper and lower sweep values toward 0%. Try 5% increments first, i.e.: Set both the **Upper Sweep** and **Lower Sweep** to -15, then -10, -5, 0, 5, and etc. The laser should intersect a barcode at each degree setting.

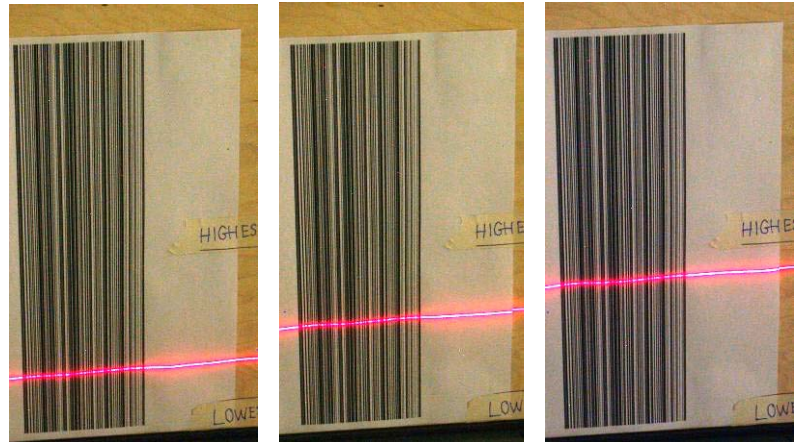

- Check the read quality on the monitor at each increment. The quality should be 100%.
- Continue incrementing the upper and lower sweep settings until the scan line reaches or goes just beyond the level of the highest barcode.

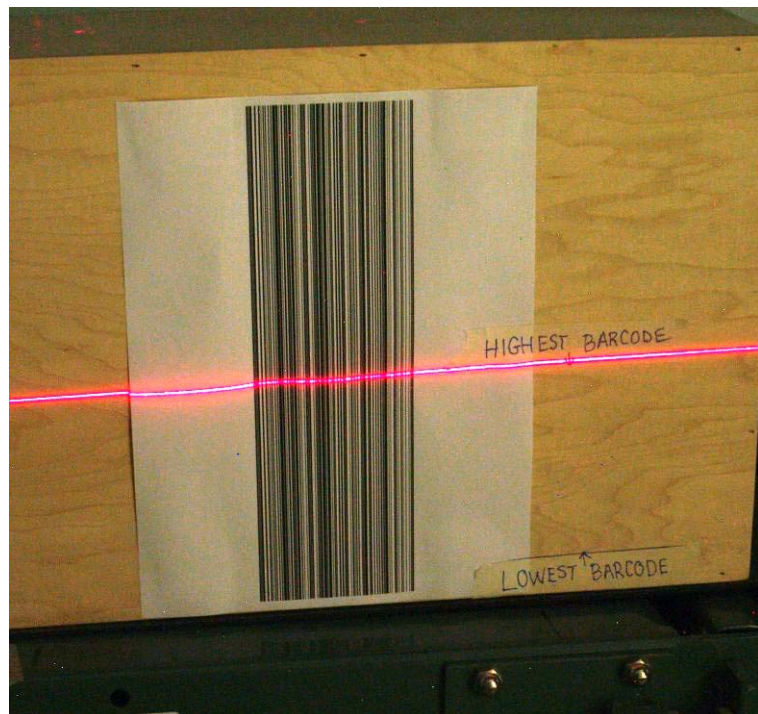

- In **Modify Settings > Raster**, set the lower sweep at -20 and the upper sweep to the value determined in step 15.

17. Click **Update**, and then click the Save icon (📁) at the top of the user interface screen. The laser will begin to sweep between your lowest and highest barcode indicators.



Run Test Labels

1. Configure the scanner for your application by setting up communications, barcode types, triggers and relays as applicable to your system (See *Chapter 5 Setup*).
2. In the user interface, navigate to **Diagnostics > Monitor**.
3. Place a test barcode at the front edge of the box in the lowest position and run the box through the system.



4. Check the **Monitor** screen to see how the barcode reads. The quality will likely not be 100%, but it is just important that it reads.
5. Next, place the test barcode at the front edge of the box in the highest position and run the box through the system.



6. Again, check the **Monitor** screen to make sure the barcode has been read.

7. Continue checking for good reads by placing the label at the back edge of the box, once in the lowest position and then at the highest position.



Dimensions and Clearances

The overall dimensions of the AL5010 when the Universal Mounting Bracket (UMB) is used are shown on the mechanical specification drawings provided in the drawings folder of the documentation CD. This section also includes drawings without the UMB.

The reader is a sealed, unventilated unit. No specific clearance is required for the purpose of cooling. However, ease-of-access should be considered when locating the mounting position.



NOTE: For installation, maintenance and service reasons, approximately 8-12 inches [203-305 mm] of clearance is recommended.

Attaching the Mounting Base

If your application is not using the universal mounting bracket (UMB), mount the mounting base to any flat surface with the two mounting screws provided.

The length of the screws must not be greater than 0.5 inch [12.7 mm] plus the thickness of the mounting surface.

Use the following diagram as a reference to create a mounting template.

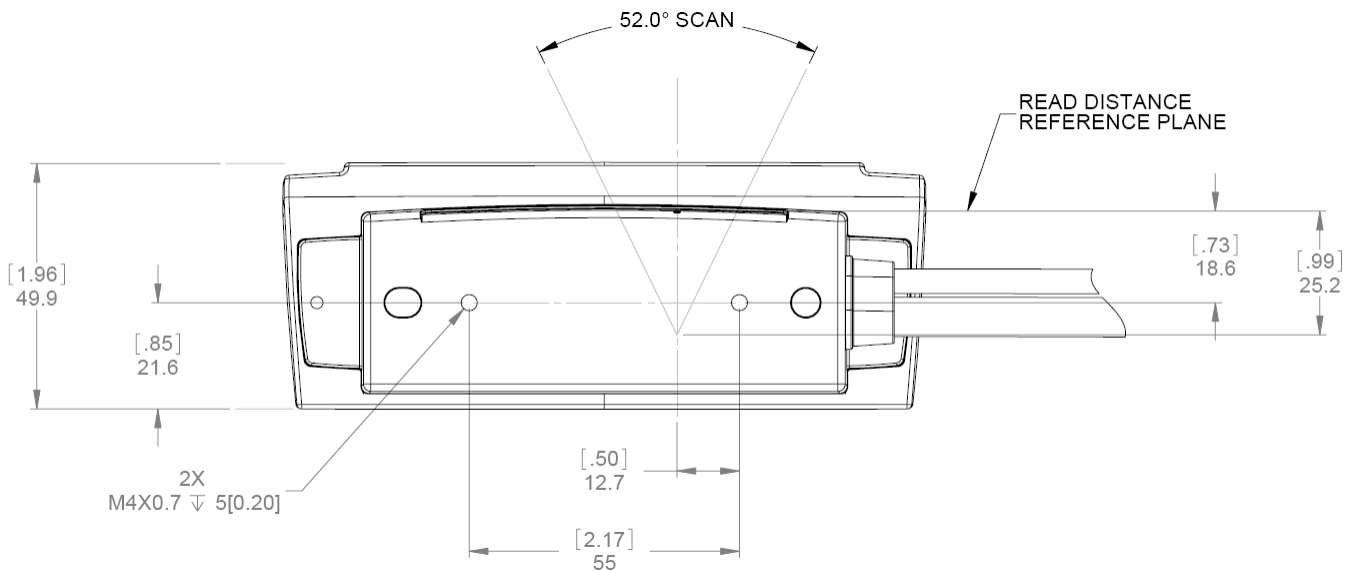

Mounting Base Dimensions (not actual size)

Attaching the Universal Mounting Bracket (UMB)

The Universal Mounting Bracket (UMB) is an optional accessory that simplifies reader mounting and installation. Included with the bracket is the necessary hardware to attach it to the mounting structure.

1. When using this option in your application, follow the assembly instructions provided with the universal-mounting bracket (UMB).
2. Attach the UMB to the mounting structure with the provided hardware.
3. Attach the mounting base to the UMB. Use the two screws provided with the mounting base.
4. Insert the screws through the UMB into the threaded holes on bottom of mounting base.
5. DO NOT over-tighten screws. Leave the screws slightly loose to allow for some movement in the mounting base so that final adjustment of the reader in relation to scanning area can be made after wiring is completed.

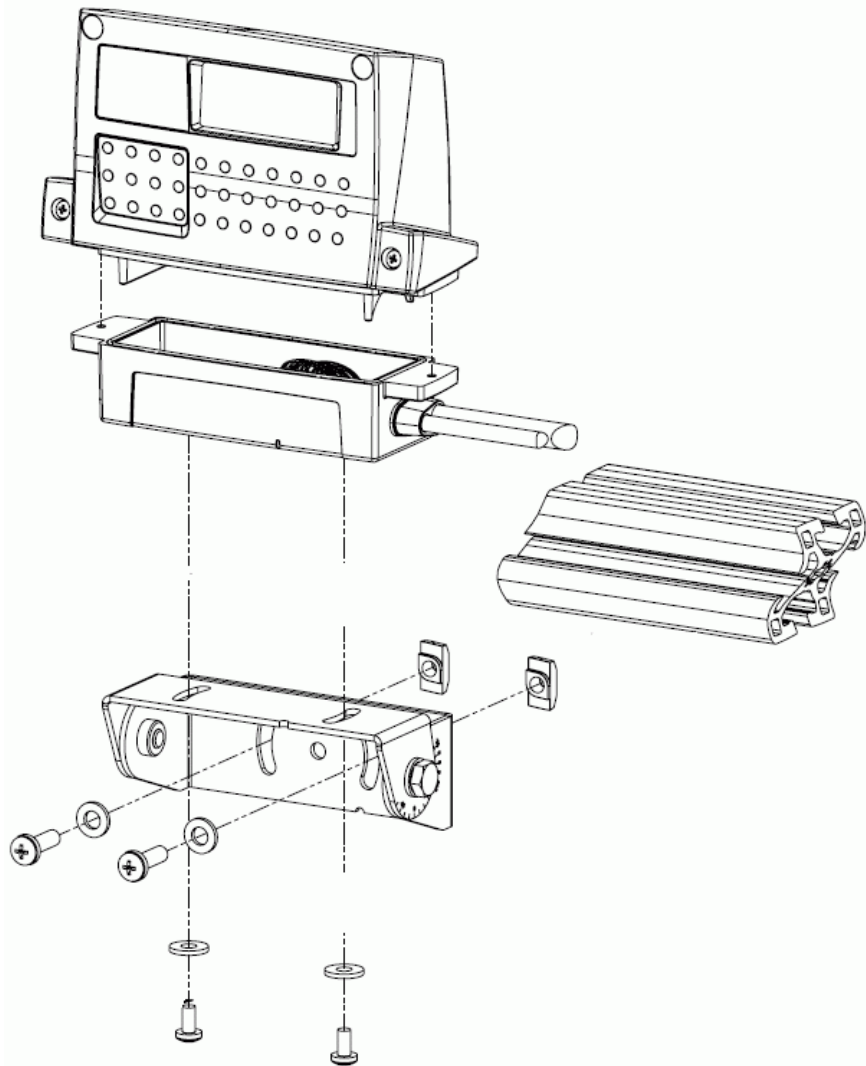

Attaching Mounting Base to Universal Mounting Bracket (UMB)

Installing an AL5010 Scan Head

Perform the electrical installation as outlined in *Chapter 4*. Once all wiring is checked for accuracy, install the AL5010 scan head to the mounting base. You can install the scan head with or without the power disconnected from the mounting base.

To install a scan head:

1. Carefully align the scan head (1) alignment tabs to the mounting base. This automatically assures the correct scan head-to-mounting base connector alignment.
2. Gently, press the scan head down until it firmly connects with the connector in the mounting base (2).
3. Tighten the two captive screws to secure the scan head to the base. Do not over tighten.
4. Adjust the UMB so the reader's laser exit window faces the approximate location of where the bar-coded packages will appear.

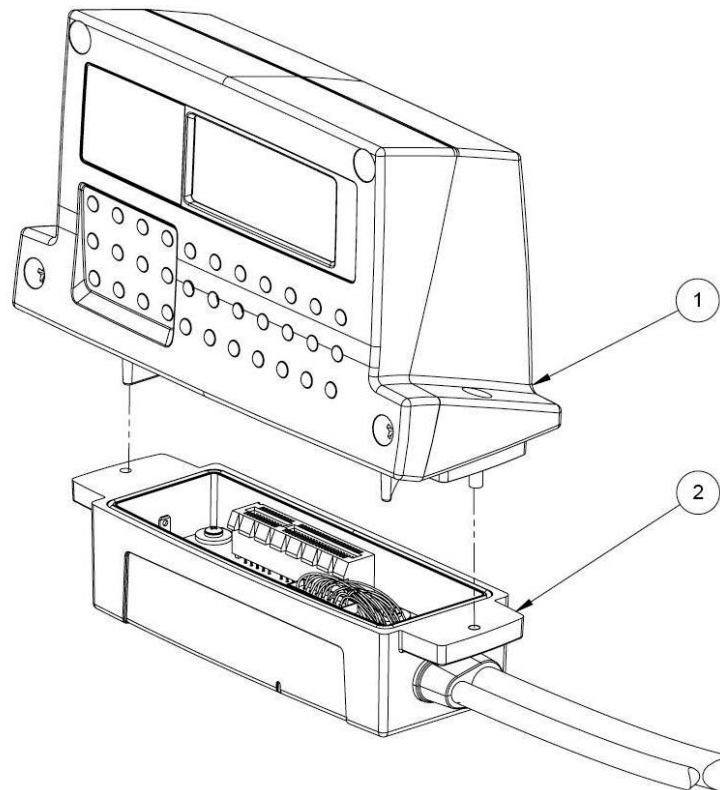

AL5010 Scan Head Installation on Mounting Base

Mounting the Trigger Photoeye

The standard photoeye works by bouncing a light beam off a reflector and detecting when something breaks the path of light. In order for photoeyes to work properly, make sure the following things are done when mounting the trigger photoeye option:

- Mount trigger and reflector so the reader's scan beam does not strike either of them.
- Mount a reflector directly opposite the photoeye on the other side of the conveyor.
- Install the reflector within the operating range of the trigger photoeye.
- The photoeye must be mounted so the light exit window is perpendicular to the conveyor, facing the reflector.
- The reflector must be mounted perpendicular to the conveyor, facing the photoeye.
- Secure the photoeye and reflector to the mounting brackets with the hardware provided.



IMPORTANT: The trigger photoeye's beam (between photoeye and reflector) must be blocked by a package before the barcode is in position for scanning. The trigger signal should remain active while the symbol is being scanned. This does NOT apply to tracking applications.

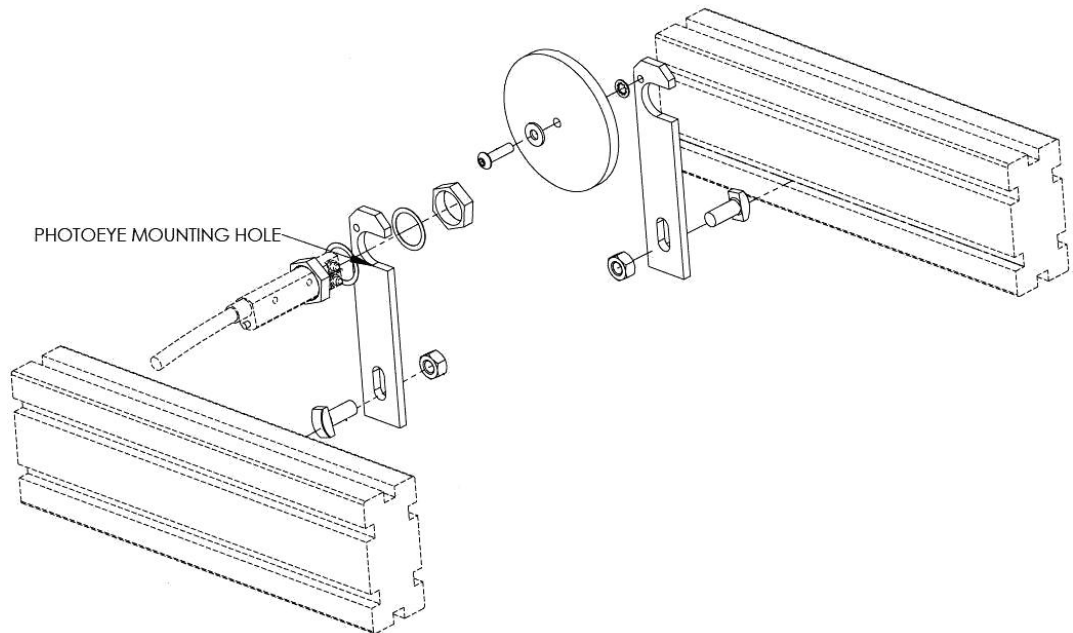

NOTE: The Trigger Photoeye can also be used in a Start/End Trigger application as the Start Trigger Photoeye. In this instance, an End Trigger Photoeye Kit (with DC input module) is also required. An End Trigger photoeye can only be used with an Enhanced Interface Module.

Mounting the Tachometer

The tachometer (tach) option outputs a set number of pulses for each wheel rotation. This tells the AL5010 the precise conveyor speed, allowing it to determine accurate package position. Tracking allows for multiple boxes to be in the scanning area at the same time. Barcodes on each box are decoded and assigned to the correct box. Follow the guidelines below:

- Mount the anti-static brush to the tachometer as shown in the drawing provided with the tach. The anti-static brush provided with the tach must be installed to assure proper operation.
- Mount the tach on the conveyor section where scanning is performed.
- Mount the tach on the underside of the conveyor, away from areas where the conveyor bows downward. A good place to mount the tach is on one end of the conveyor, underneath the drive shaft.
- Make sure the tach assembly angles in the same direction that the underside of the conveyor travels.
- The tach must make good contact with the conveyor.
- Use the general mounting kit provided with your system to make tachometer mounting and setup easier.

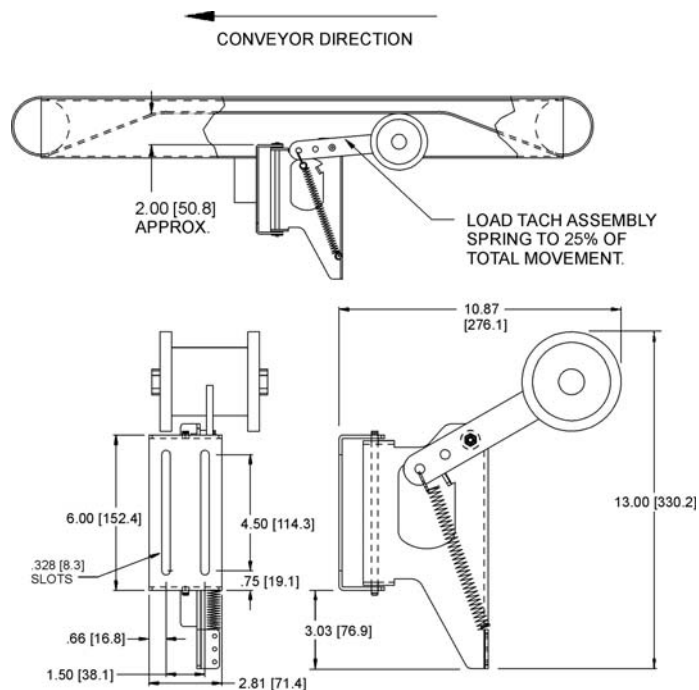

Tachometer Mounting (anti-static brush not shown)

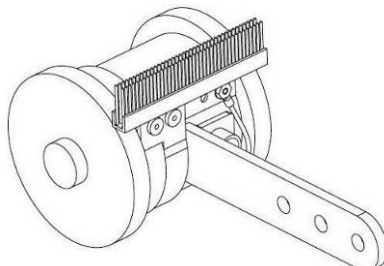

Tachometer with Anti-Static Brush Installed

Mounting the Interface Modules

Mechanical installation sequence for AL5010 with either the Basic or Enhanced Interface Module:

1. Determine the location of the scanning system at the installation site.
2. Erect the mounting frame or other supporting structures.
3. Mark the mounting locations for each:
 - a. AL5010 Reader
 - b. Basic or Enhanced Interface Module
4. Attach the Universal Mounting Bracket(s) (UMB) to the frame. (UMB and mounting frame options are available from Accu-Sort.)
5. Attach the AL5010 Mounting Base to the UMB (or frame, if UMB not used).
6. Mount the Basic or Enhanced Interface Module. (*See below.*)
7. Mount the Accu-Sort power supply.
8. Mount the Trigger Photoeye (optional).
9. Mount the Tachometer (optional).

To mount the Basic Interface Module:

1. Position the basic interface module in the desired mounting position.
(Position the cord grips so they are face down or to the side.)
2. Using a Phillips screw driver, attach with the supplied mounting hardware.

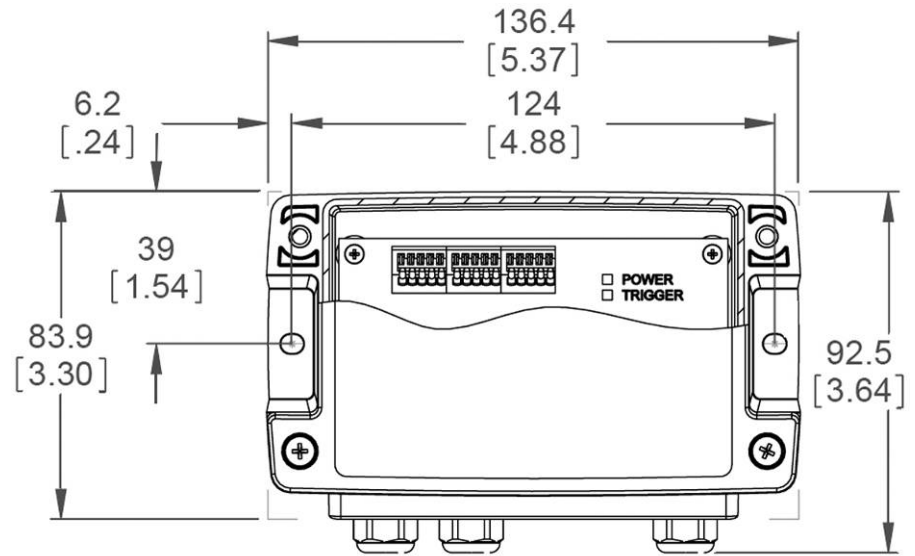

To mount the Enhanced Interface Module:

1. Position the basic interface module in the desired mounting position.
(Position the cord grips so they are face down or to the side.)
2. Using a Phillips screw driver, attach with the supplied mounting hardware.

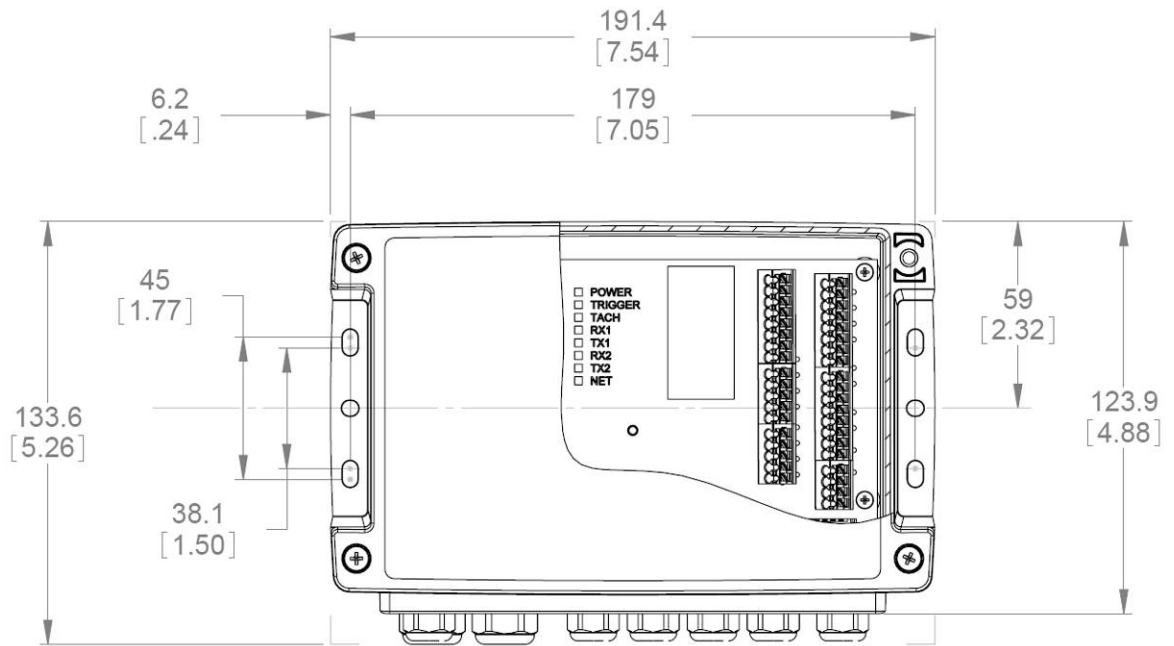

Mounting the I/O Modules

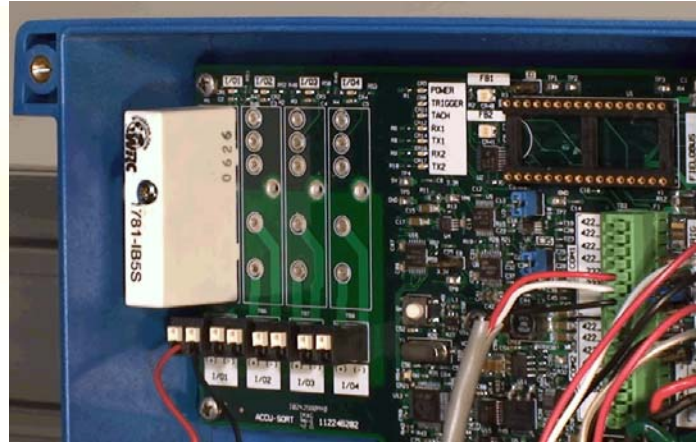

I/O MODULE APPLICATIONS

OUTPUT MODULES

- Activate diverter/sorter for no read, multi-read, match, or no match conditions.
- Activate device (e.g., beacon light) to indicate any of the above conditions.
- Activate device for use as a "life condition" indicator.
- Activate device to follow the trigger condition.
- Activate alarm.

INPUT MODULES

- Additional photoeye input for Start/End Trigger

NOTE: The following input module applications require custom software.

- Transmit photoeye
- Divert Accomplished photoeye
- Reboot signal

The Enhanced Interface Module supports four (4) optional input or output modules that can be used for trigger inputs or to operate diverters, alarms, etc. The optional I/O modules are not installed at the factory.

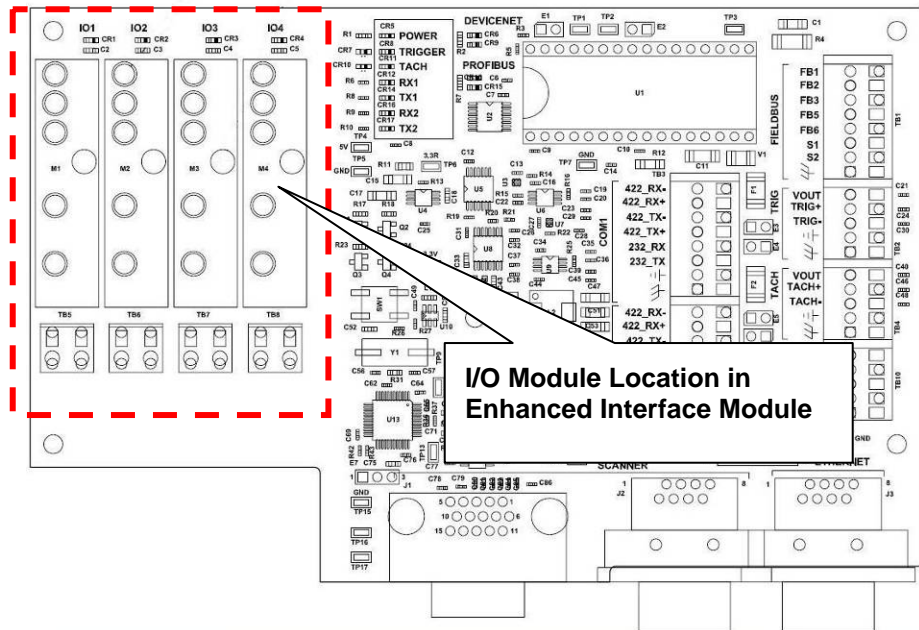

To install your optional I/O module(s):

1. Remove the cover to gain access to the printed circuit board.
2. The I/O modules may be plugged into locations I/O 1 through I/O 4. These locations run left-to-right, as shown on the circuit board silkscreen.
3. Plug the appropriate I/O module directly into the interface module's circuit board.
4. Using a screwdriver, secure the I/O module by tightening the captive screw (that goes through the module) into the circuit board. **DO NOT** over-tighten screw.

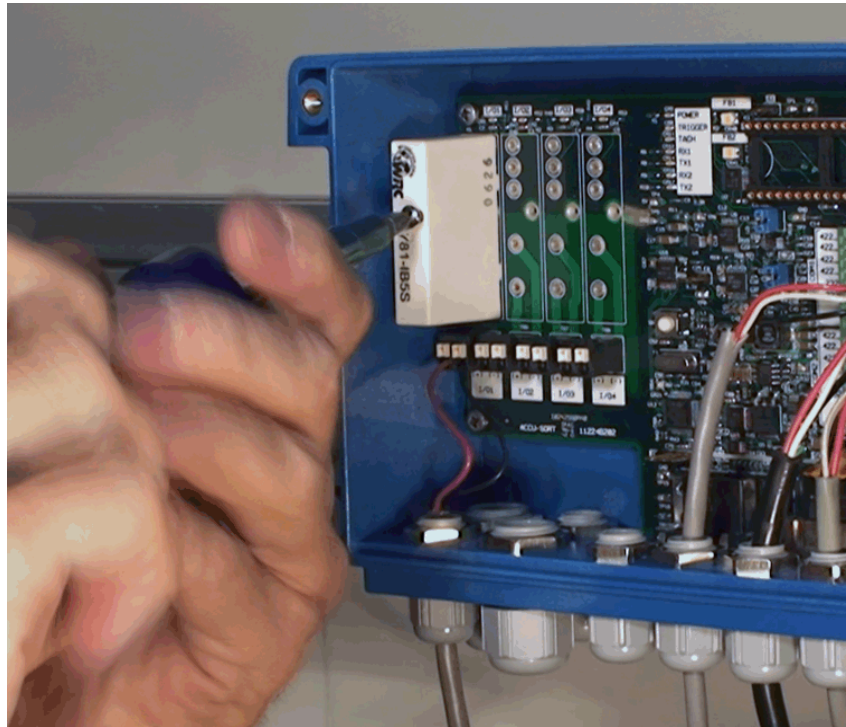

Installing an I/O Module

4 Electrical Installation



WARNING: Electrical Installation by Qualified Service Technicians Only! Several procedures involve exposure to voltage inside the interface module. A trained technician must perform these procedures. Do not attempt to perform any electrical installation procedures unless you are a trained technician.



WARNING: There are no user serviceable parts inside the AL5010. No internal components of the AL5010 are field replaceable units (FRUs). Opening the unit will potentially expose the user to emitted laser radiation, high voltage, and could reduce the effectiveness of the device's IP rating. **DO NOT REMOVE** the faceplate from the scan head enclosure. Opening the AL5010 will also void the factory warranty.



IMPORTANT: The AL5010 contains electronics that may be affected by electrostatic discharge (ESD). To prevent personal injury or damage to the unit, please follow the safety precautions and warnings found in *Chapter 2*. Failure to follow these precautions may void your warranty.

Prerequisites

Before mounting any components, please do the following:

- Read all instructions before beginning your installation.
- Define and confirm the accuracy of your application's requirements.
- *Review the standard electrical wiring drawings provided in Appendix F.*
- Review all installation-specific drawings.
- Review and plan the power requirements for your application.
- Review and plan the communications requirements for your application.

Tools Required

- Phillips Screw Driver (#1)
- Flat Head Screw Driver (small)
- Wire Cutters
- Wire Strippers
- Needle-nose Pliers

Additional Information

See also: **Quick Reference Guides** for Installation

- AL5010 with Basic Interface Module (1000070256)
- AL5010 with Enhanced Interface Module (1000070257)
- Establishing A Connection to the User Interface (1000070258)
- Getting Started with the User Interface (1000070259)

These guides are available online at:

http://www.accusort.com/en/about/regform_downloads_al5010.php

Installation Sequence(s)



NOTE: Everything should be MECHANICALLY INSTALLED before performing any ELECTRICAL INSTALLATION. See *Chapter 3* for mechanical installation details.

Installing a Single Unit

To install a single unit, follow this sequence of steps:

- **Complete mechanical installation.**
 - See Chapter 3.
- **Complete electrical installation.**
 - Ground the mounting structure to protective earth (PE) ground.
 - Connect AL5010 reader to interface module (two connections).
 - Connect Ethernet network to interface module.
 - Connect the power supply to interface module.
 - Connect trigger to interface module.
 - Connect tachometer to interface module (Enhanced Interface Module Only).
 - Connect serial communications to interface module.
 - Connect wiring for I/O module(s) to interface module (Enhanced Interface Module Only).
 - Install Fieldbus if needed- *DeviceNet* or *Profibus* (Enhanced Interface Module Only).
 - Attach scan head to mounting base.



NOTE: To reduce the possibility of damage to the scan head, install it after the interface module is mounted, wired, and all wiring is checked for accuracy. Be sure to perform the polarity check before attaching the scan head.

- **Setup your AL5010.**
 - See Chapter 5.
- **Check operations.**
 - See Chapter 6.

Installing Multiple Readers

For electrical installation, multiple-reader networks will require a different approach to wiring, since the trigger photoeye and tachometer are most likely being shared by the group of readers.

(See drawing 113492 in Appendix F.)

Special instructions for functional set-up of a multi-reader network are provided in *Chapters 5 and 6.*



NOTE: If Tracking, Fieldbus and/or I/O Modules are not needed, an Enhanced Interface Module is not required.

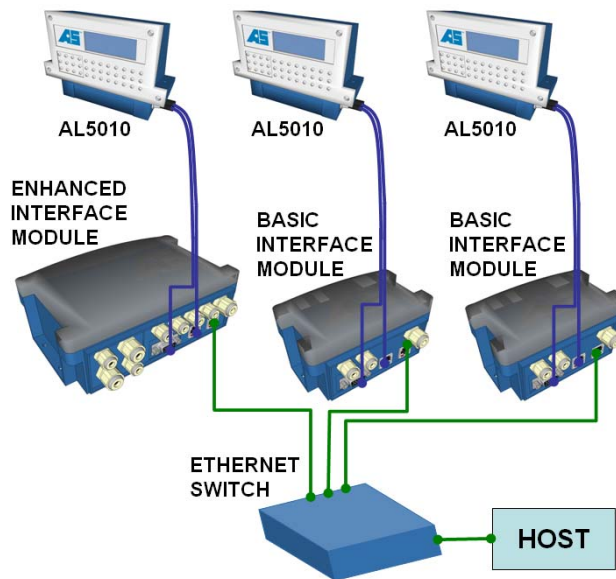

Multiple Readers with EtherNet Communications

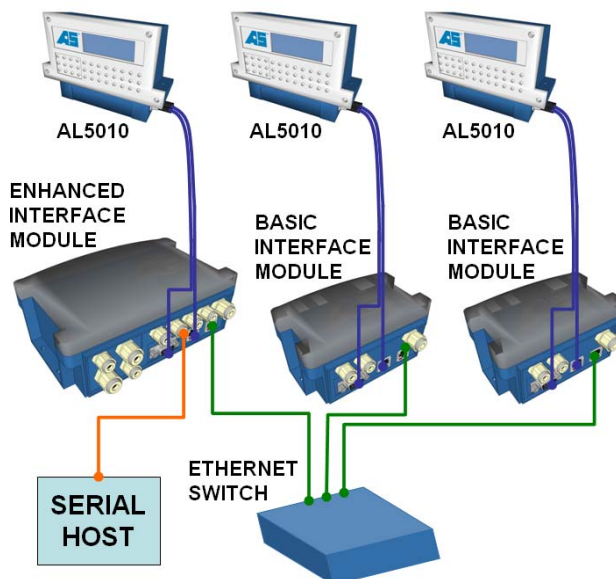

Multiple Readers with Serial Communications

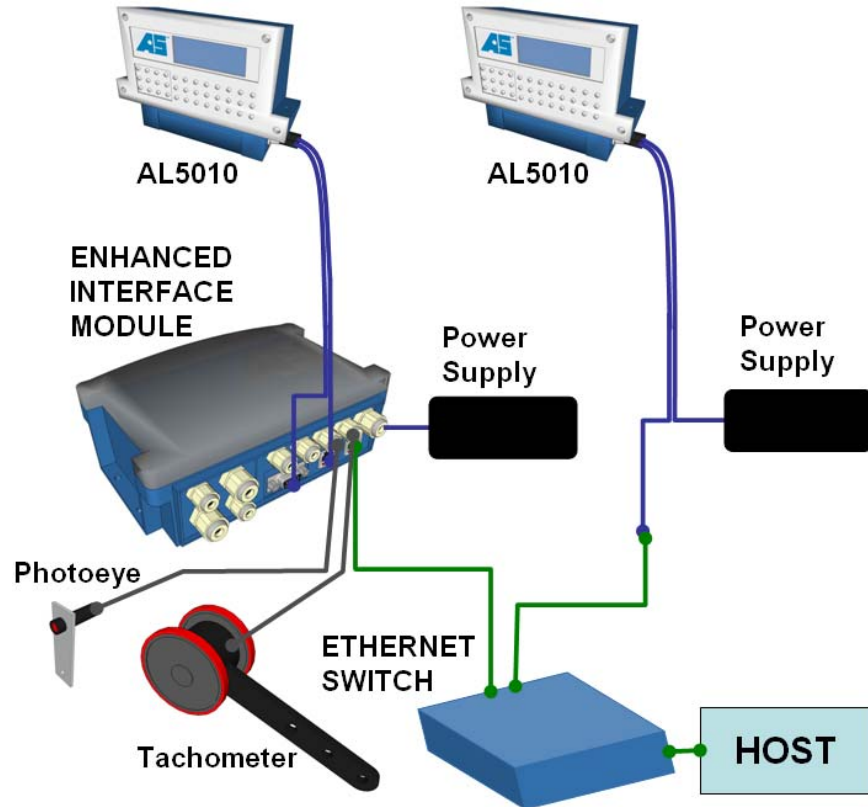

Multiple Readers with a Single Interface Module

General Electrical Installation Guidelines and Precautions

It is important that you follow these general precautions when installing, setting up, operating, maintaining, troubleshooting or replacing any Accu-Sort products, parts or related equipment.



CAUTION: The AL5010 use lasers for bar code scanning. Do not view directly with optical instruments (binoculars or telescopes). Avoid unintentional exposure to laser light whenever possible.

As you plan and install your AL5010 bar code solution application, be sure to keep the following guidelines in mind:

- Determine the reader is in the proper orientation and position as outlined in Chapter 3.
- Leave adequate clearances (approximately 8-12 inches [203.2-304.8mm]) for wiring.
- The interface modules have several cord grip openings. Seal unused openings with rubber grommet plugs (units ship with rubber plugs in place). Remove the grommet plugs when inserting cables. Use cord grips with rubber grommets on cables that enter the interface module.
- Route wires carefully to reduce or minimize electrical noise. The interface modules are designed so power and communication wiring should not need to cross.



WARNING: To assure no ESD damage will occur, be sure to observe the precautions outlined in *Chapter 2, Safety*.

Cable and Cord Grip Connections

Determine the wiring connections needed for your application. All permanent connections are made to the basic or enhanced interface module with either cables or through cord grips. Be sure to follow Accu-Sort's wiring recommendations.

Wiring Recommendations

Connection	Recommended Wiring Type	Max. Length
Safety Earth Ground	For 15-20 Amp branch circuit, use #18 AWG min. For 16-25 Amp branch circuit, use #14 AWG min. For 26-32 Amp branch circuit, use #12 AWG min.	
Power	#20 AWG minimum	
RS232	#24 AWG minimum	50' [15.2]
RS422	#24 AWG minimum	1000' [300]
Ethernet	#24 AWG CAT5 UTP (unshielded twisted pair)	330' [100]
Tach / Trigger	#24 AWG minimum	
I/O Modules	Depends upon module rating. See Appendix A .	

NOTE: ALL external wiring must be UL listed or recognized rated VW-1 or FT-1 and conforming to NEC ANSI/NFPA 70.

Cord Grips	Recommended Wiring Diameters
Small Diameter	Accommodates 0.138 to 0.276 inches (3.5 to 7.0 mm)
Large Diameter	Accommodates 0.177 to 0.394 inches (4.5 to 10.0 mm)

Cable Connections to Interface Module

- Where the cabling enters the interface module, use the supplied cord grips with rubber grommets.
- Once all cabling is completed, plug all unused interface module openings.



IMPORTANT: All unused openings must be plugged to maintain the Interface Module's IP54 rating.

Proper Wiring to Terminal Blocks inside Interface Modules

1. If necessary, strip the insulation off the end of wire approximately 1/4" [6,35mm].
2. Use flathead screwdriver to push the spring-cage terminal block open until it stops.
3. Insert wire into terminal opening.
4. Allow the screwdriver to release the spring-cage terminal block.
5. Confirm the wire is held firmly in place.

Wiring the AL5010 Interface Modules

After completing mechanical installation, use this section to properly wire your AL5010 reader for optimal performance in your application. All wiring connections are made via a basic or enhanced interface module.

Use the conduit openings for running wires into the interface module. Route your cabling for power, tachometer, trigger, communications, and I/O through the recommended conduit openings.

Basic Interface Module

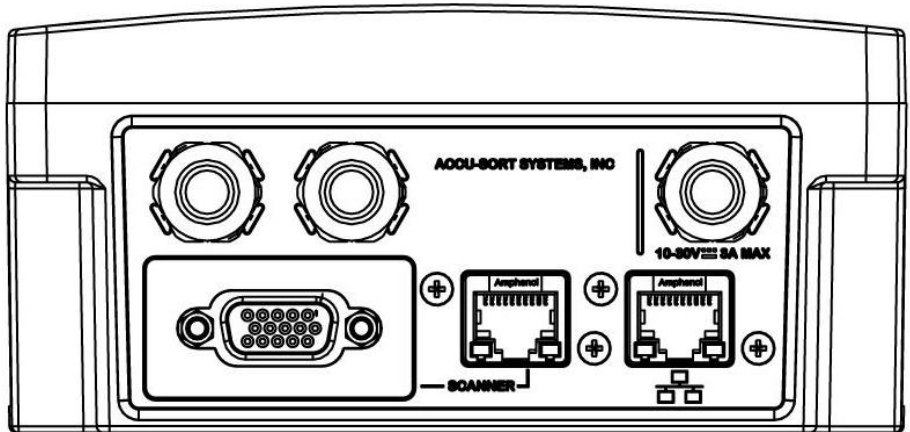

Basic Interface Module

Wiring tables, printed on the interface module, help simplify installation.

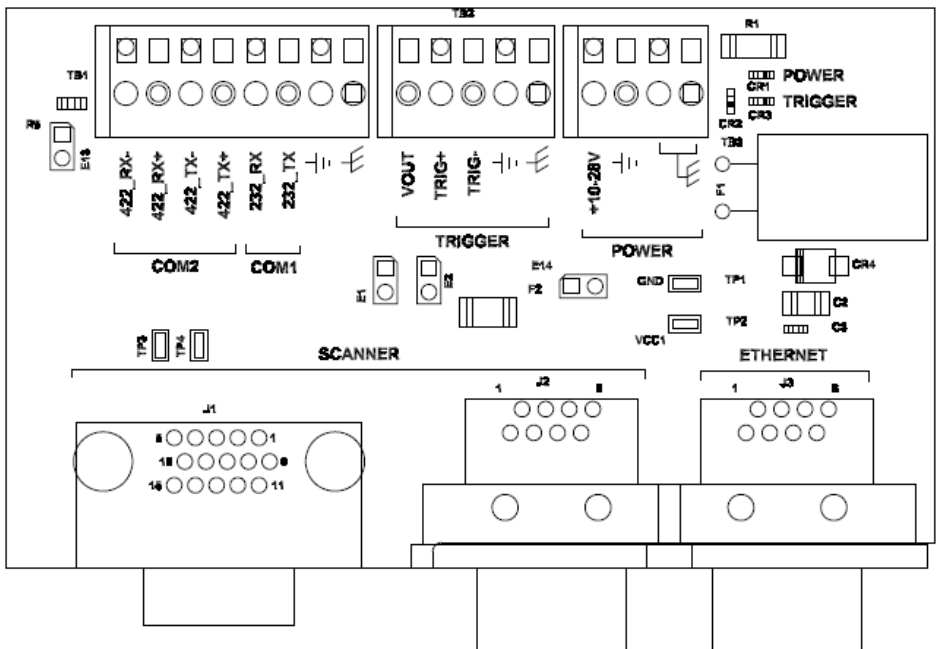

Basic Interface Module Terminal Block Locations

See also: Drawing 113491 in Appendix F.

Electrical wiring sequence:

	Cable Jacket Stripping	Strip All Wires
1. SCANNER - Mounting base (two connections, 15-pin 'D' and RJ-45)		
2. ETHERNET - Host (Network)		
3. COM 1 / COM 2 - Serial communications	COM 1 = 3 1/2", COM 2 = 3"	1/4"
4. TRIG - Trigger	3 1/2"	1/4"
5. POWER - Power supply or user-supplied	2 3/4"	1/4"

Wiring Installation Sequence (Connection Panel)

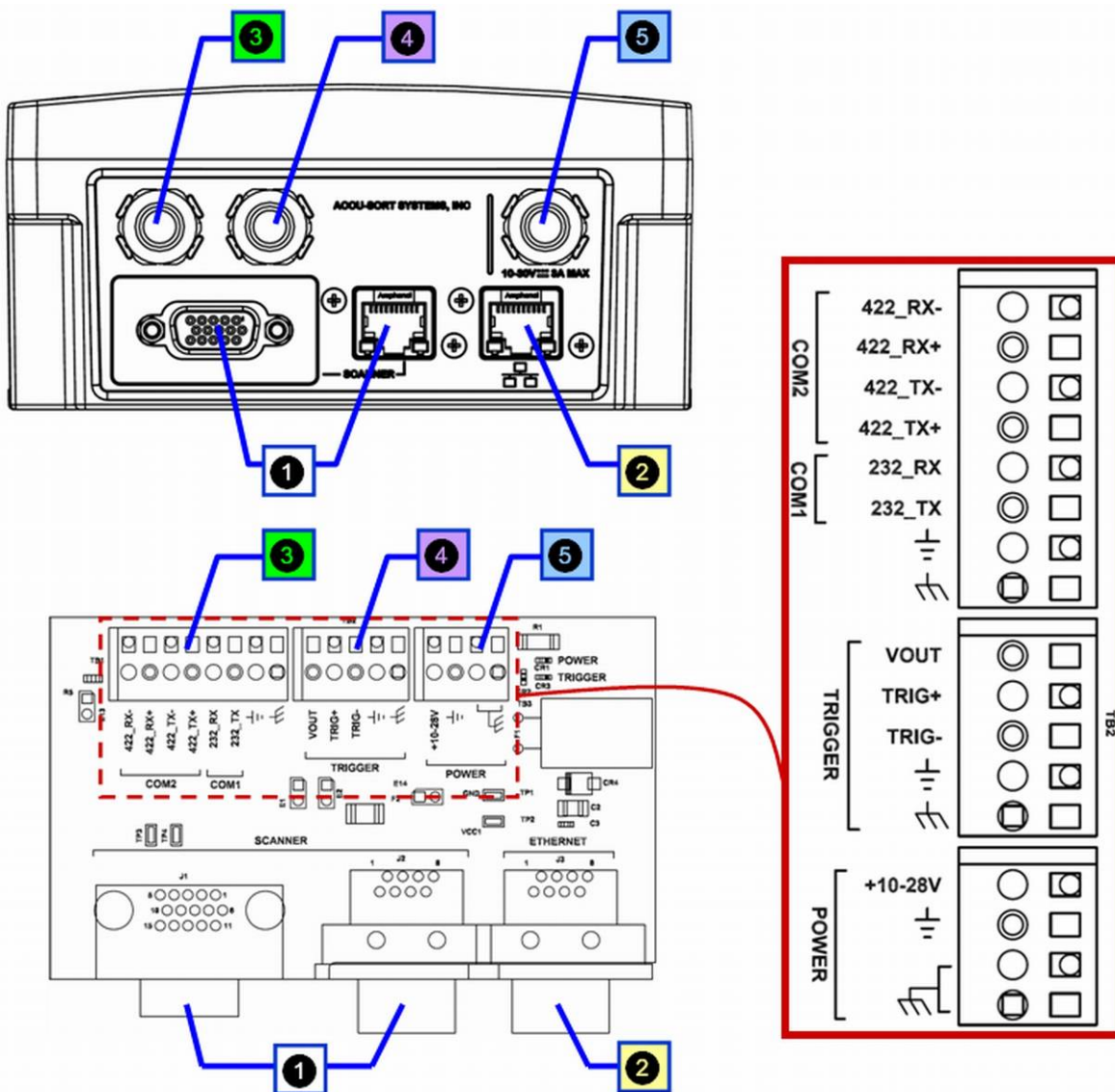

Wiring Installation Sequence (Circuit Board) and TB Wiring Tables

Enhanced Interface Module

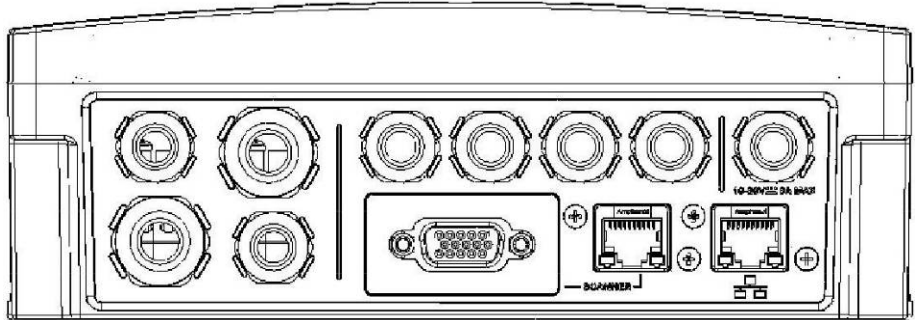

Enhanced Interface Module

Wiring tables, printed on the interface module, help simplify installation.

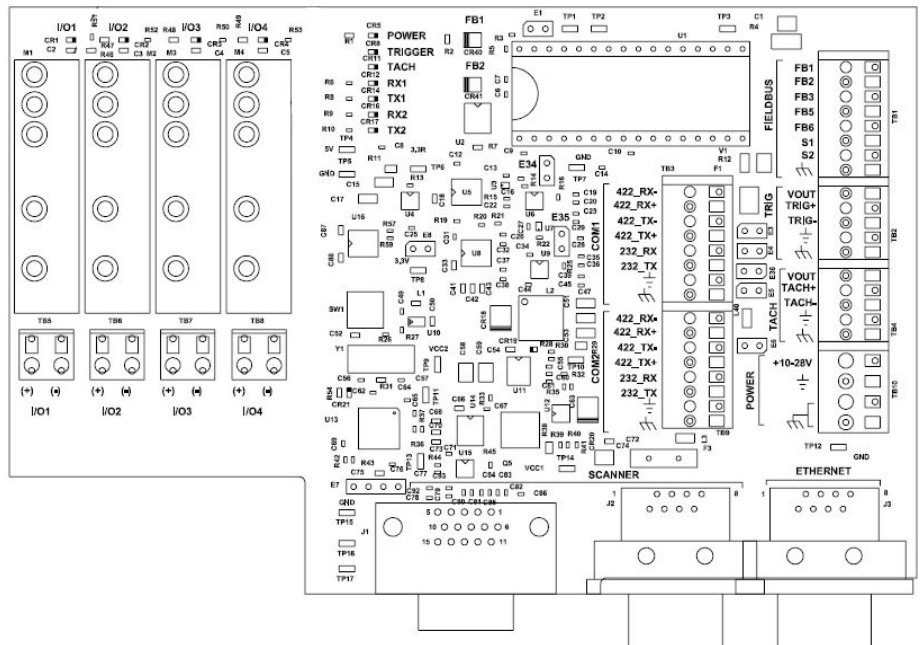

Enhanced Interface Module Terminal Block Locations

See also: Drawing 113490 in Appendix F.

Electrical wiring sequence:

	Cable Jacket Stripping	Strip All Wires
1. SCANNER - Mounting base (two connections, 15-pin 'D' and RJ-45)		
2. ETHERNET - Host (Network)		
3. COM 1 / COM 2 - Serial communications	COM 1 = 3 1/2", COM 2 = 3"	1/4"
4. FIELDBUS (DeviceNet or Profibus, optional)	4 3/8"	1/4"
5. TRIG - Trigger	3 1/2"	1/4"
6. TACH - Tachometer	3 1/4"	1/4"
7. POWER - Power supply or user-supplied	2 3/4"	1/4"
8. I/O 1 through I/O 4 - I/O module(s) (optional)	2 1/2"	1/4"

Wiring Installation Sequence (Connection Panel)

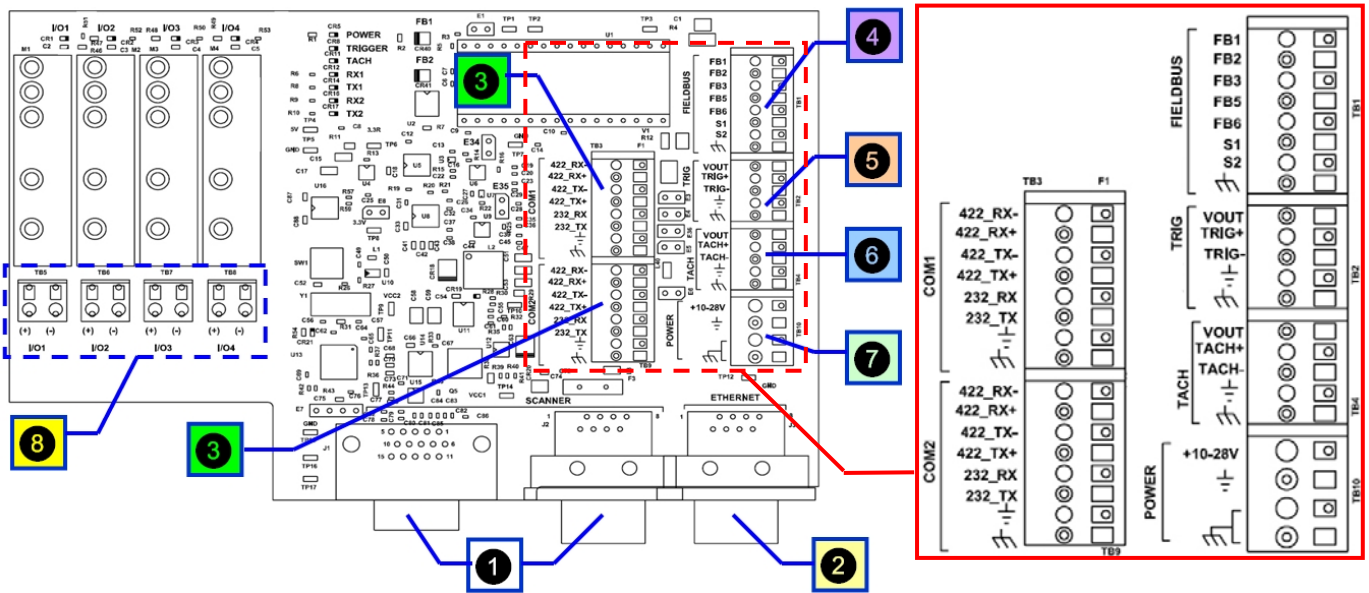
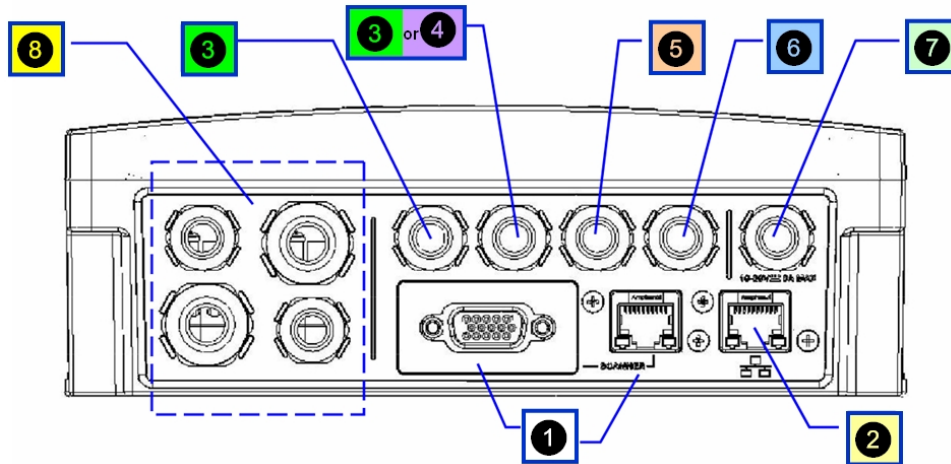

Wiring Installation Sequence (Circuit Board) and TB Wiring Tables

Power Requirements



IMPORTANT: When planning your installation wiring, remember all power connections must be quick-disconnect. For PERMANENTLY CONNECTED EQUIPMENT (i.e., AL5010 using DC power) a readily accessible disconnect device must be incorporated in the building installation wiring. For PLUGGABLE EQUIPMENT (i.e., AL5010 using AC power supply with non-detachable power cord), the socket-outlet must be installed near the equipment and must be easily accessible.

Power Supply Connections



CAUTION: Follow all safety procedures regarding high-voltage as outlined in *Chapter 2, Safety*. No power should be applied to any device until all wiring is completed and checked for accuracy.



REMEMBER: The socket-outlet must be installed near the AL5010's power supply. The outlet must be a readily accessible disconnect device.

Using Accu-Sort Power Supplies

Single Reader The AL5010 reader requires 25 watts (maximum) of power. The Accu-Sort power supplies are IP54 rated for industrial environments. The supply includes a power cord for either 125V or 230V applications.

1. Locate the POWER terminal blocks on the interface module.
2. Connect the power supply wiring to the terminal blocks as shown below.
3. Make sure wiring cannot come loose from the terminal blocks.
4. Properly tighten the cord grips.

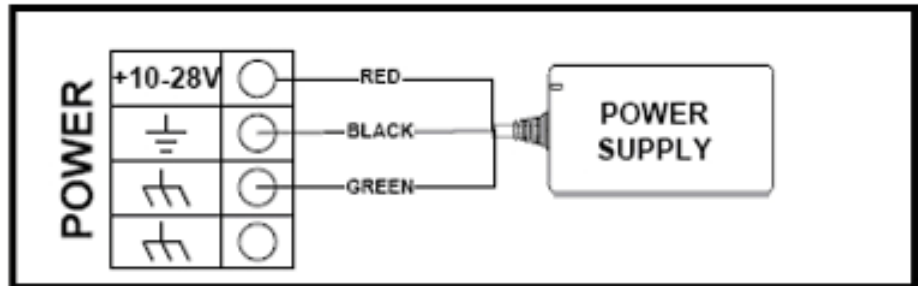

Multiple Readers When a multiple reader application uses Accu-Sort power supplies, each AL5010 is powered by a separate power supply. DO NOT connect power supplies in parallel. (See drawing in Appendix F.)

Power Connections Using Other Power Supplies



IMPORTANT: All non Accu-Sort power supplies, whether for single or multiple reader applications, must be an LPS or Class 2 power supply. The supply must provide 25 watts (10-28 VDC) of power to *each* AL5010.

Trigger Connections



The AL5010 supports three trigger modes: hardware, software, and continuous. When using hardware trigger, one or more input signals “trigger” the reader. Software trigger is accomplished by sending a specific ASCII message via serial or network communications. Continuous trigger requires no external trigger.

When a hardware trigger (i.e., package detector) is required, Accu-Sort’s retro-reflective photoeye (PN 100020569) is recommended.

Wiring Trigger to the Enhanced Interface Module

Connect trigger wiring to the interface module terminal blocks. Wire the Accu-Sort photoeye as shown below.

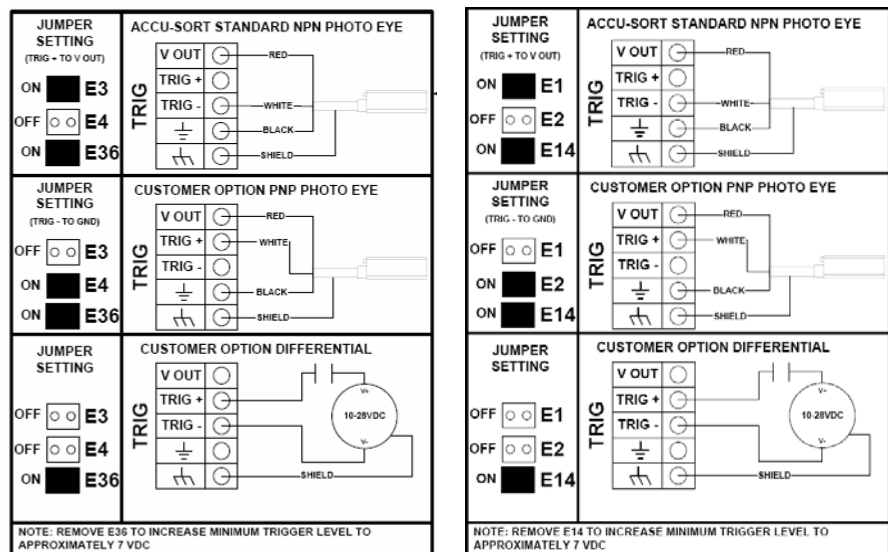

Enhanced Interface Module

Basic Interface Module

In applications using a photoeye other than the Accu-Sort standard, follow the TRIGGER wiring table to assure proper wiring. The trigger must be able to operate using the +24V DC source (24V) and not draw more than 100mA. The trigger input must be able to sink (or source) 10mA at +24V DC.



NOTE: To confirm the Trigger photoeye is functioning properly, watch the Trigger LED while the photoeye’s beam is blocked. (See Chapter 5 for details.) The Accu-Sort photoeye also includes a status LED.

Multiple Readers In controller/client applications, wire the trigger photoeye to the AL5010 set up as the controller. (See drawing in Appendix F.)

Tachometer Connections

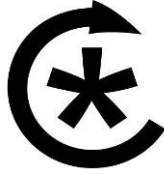

In applications where product tracking is required, a tachometer is typically used. When a tachometer is required, the Accu-Sort tachometer is recommended. Connect the tachometer wiring to the interface module terminal blocks.

Wiring Tachometer to the Enhanced Interface Module

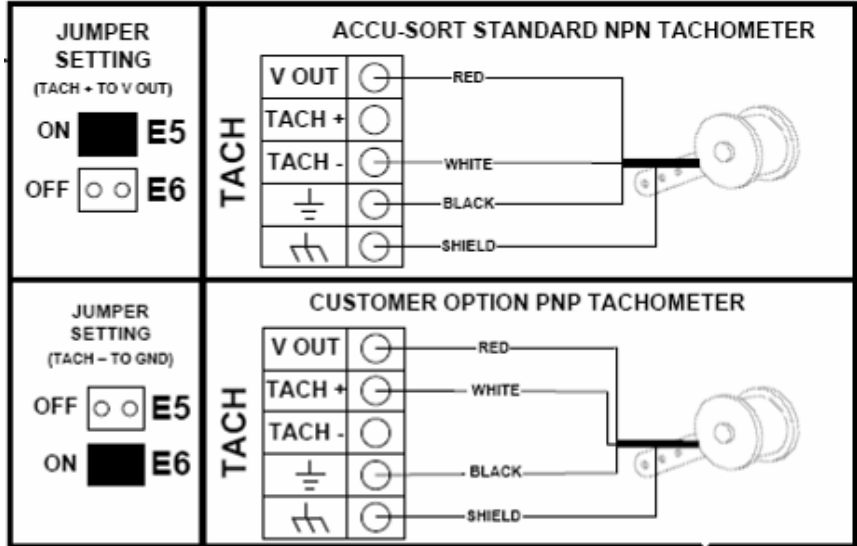

WARNING: The maximum tachometer current should not be more than 0.3 amps @ 24 volts.

If your application uses a tachometer other than the one available from Accu-Sort, follow the TACH wiring table to assure proper wiring.

Multiple Readers In controller/client applications, wire the tachometer to the AL5010 set up as the controller. (See drawing in Appendix F.)

Serial Communications Connections (COM1 and COM2)



The interface module provides an RS232/RS422 terminal block for serial point-to-point communications. Typically, network communications will use Ethernet.

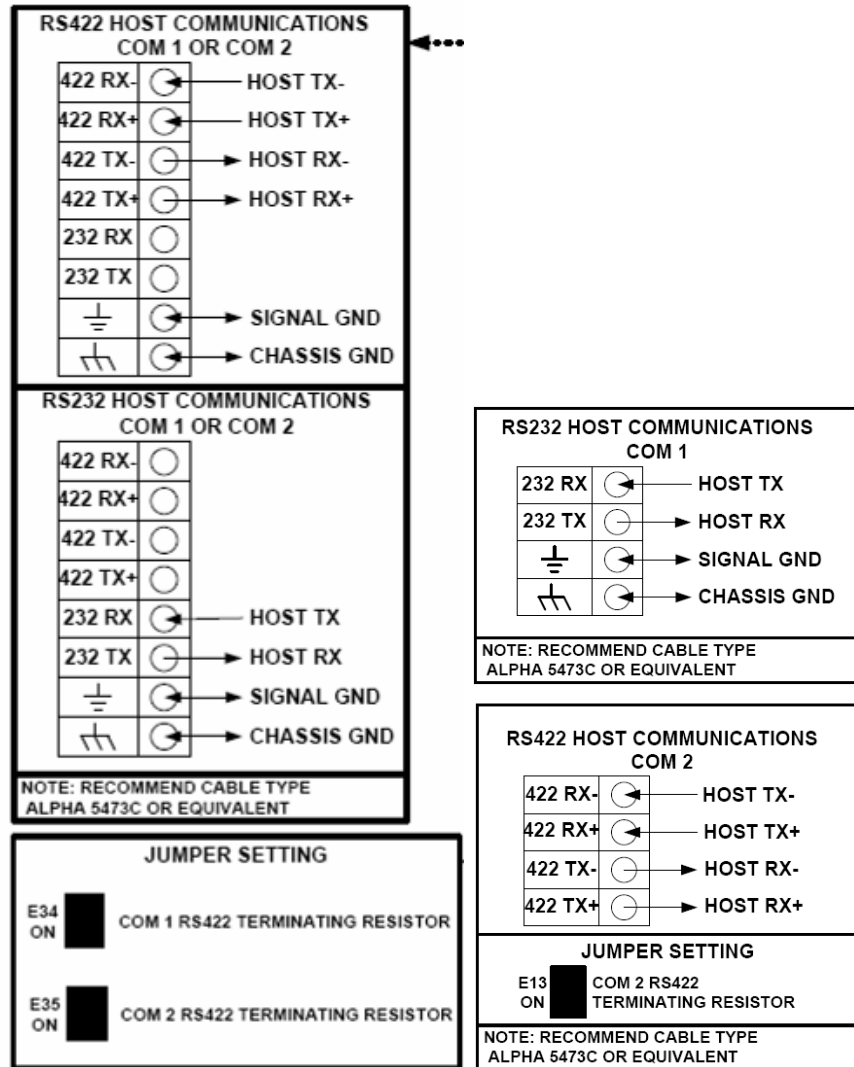

Enhanced Interface Module Basic Interface Module
Serial Communications Wiring (RS232/422)

RS232 Connections

Use RS232 for a direct connection to a controller, personal computer, or other device. RS232 provides point-to-point communications at distances up to 50 feet (15.2 meters). If longer cable lengths are needed, use RS422. RS232 connections are made to the **COM1** and **COM2** terminal blocks. Follow the SERIAL COM / RS232 wiring table to assure proper wiring.



IMPORTANT: Before attempting to use RS232 communications with RTS/CTS, contact Accu-Sort Customer Service for additional information.

RS422 Connections

Use RS422 for a direct connection to a controller, personal computer, or other device. RS422 provides point-to-point communications at distances up to 1000 feet (300 meters). RS422 connections are made to the **COM1** and **COM2** terminal block. Follow the SERIAL COM / RS422 wiring table to assure proper wiring.

Line Termination The end devices on an RS422 point-to-point connection must be terminated. A termination resistor is pre-installed in the interface module. The HOST end of the connection must also be terminated using a 120-ohm resistor between the RECEIVE+ and RECEIVE- terminals.

Ethernet Communications Connections

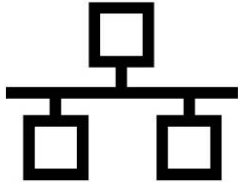

Use Ethernet for network/host communications or multiple-reader networks. Ethernet communications cabling can be run up to 330 feet (100 meters). Ethernet connections are made to the Network connector on the Interface Module's connector panel.

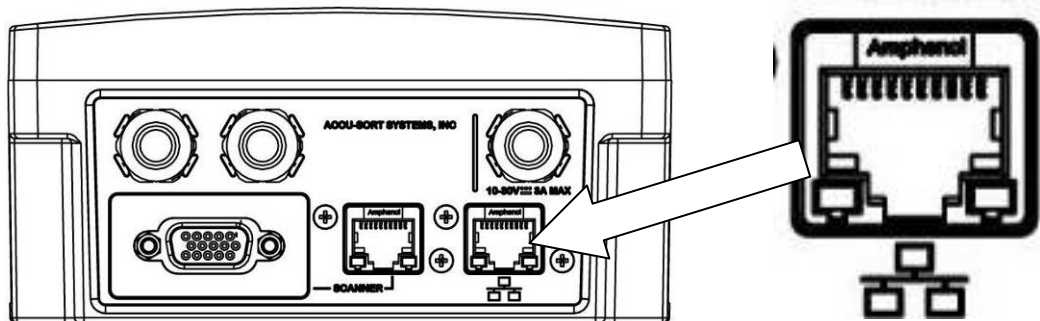

Ethernet Connections to Basic Interface Module



NOTE: To simplify network installations, Accu-Sort offers these options:

- CAT 6 network cables (7 and 15 ft. lengths)
- a 5-port Ethernet switch (dual speed 10/100) and
- an 8-port dual speed Ethernet switch (10/100).

Multiple Readers Most multi-reader applications will use Ethernet or EtherNet/IP communications. See drawing 113492 in *Appendix F* for wiring details.

I/O Module Connections

The **Enhanced Interface Module** supports up to four (4) optional input or output (I/O) modules. The modules listed in the table below may be used. These modules function like switches; they do not supply a voltage. (See Appendix A.)

Connect I/O wiring to the correct terminal blocks. When using DC modules, observe the polarity of the connections illustrated on the circuit board.

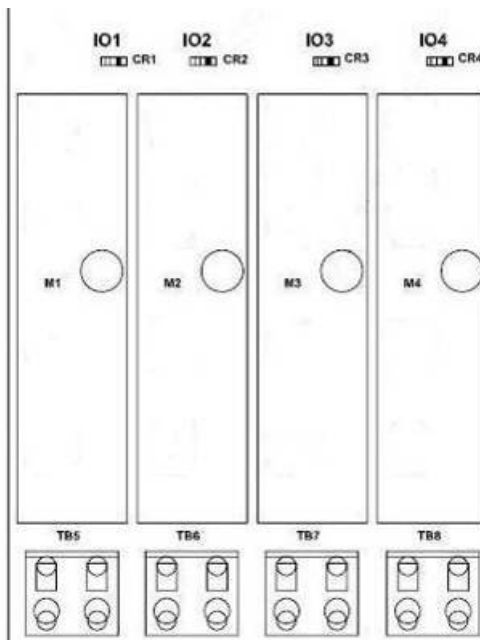

I/O Module Wiring

Available I/O Modules for use with AL5010

Part Number	Description	Color	Rating	Current Range
1000056135	DC Input Module	white	3.3 to 32 VDC	32 mA
1000056136	DC Output Module	red	3 to 60 VDC	3 A max. *
1000056137	AC Output Module	black	12 to 42 VACPeak	3 A max. *



NOTE: Relay modules are only for connection to SELV, LPS power source and shall also meet the requirements for Class 2.

* Derate 33mA/deg above 25C.

See also: Drawing 113490 in Appendix F.

Output Module Application

Shown below is a typical output module application. When connecting high impedance loads, you may need to add a resistor in parallel with the load. This resistor (typically 300 to 6,000 ohms) provides a continuous minimum current flow (10 mA DC or 50 mA AC) through the output module in the closed state.

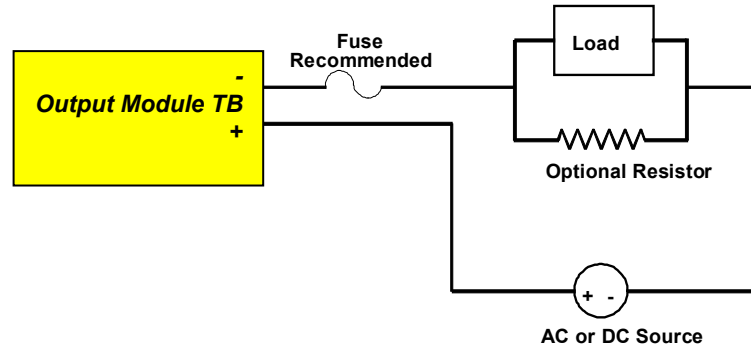

Optional Resistor for High Impedance Loads

Back Electromotive Force (EMF) is sometimes generated when an inductive load is switched off. Back EMF may damage the output module. A diode in parallel with the inductive device dissipates the back EMF.

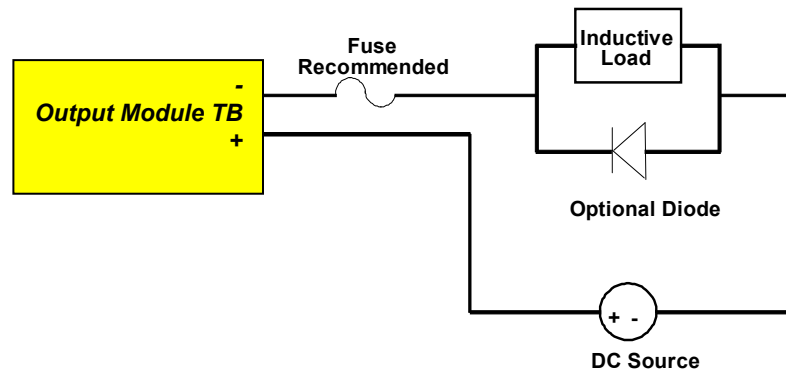

Optional Diode to Dissipate Back EMF

An example output module application is the use of a Stack Light. The AL5010 would use three output modules to send signals to the stack light to visually indicate specific conditions (e.g., green = read, yellow = multiple codes, red = no read). (See drawing in Appendix F.)

Input Module Application

Input module 1000056135 is most often used for an End Trigger Photoeye application. (See drawing 113490 sheet 3 in Appendix F.)



NOTE: Any other input module application requires custom software. Contact Accu-Sort Customer Service for more information.

DeviceNet

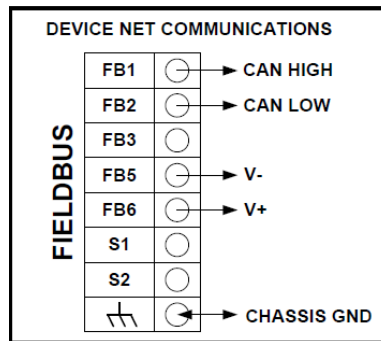

Profibus

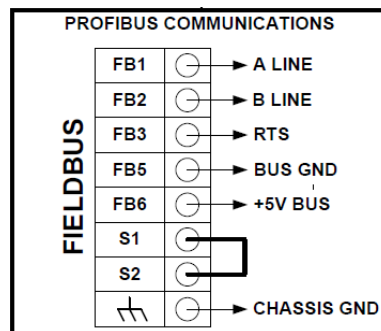

Connecting the AL5010

Once all wiring is completed and checked for accuracy, connect the AL5010 Reader's cable connections to the Interface Module. (See *Wiring the Interface Modules in this chapter.*) You can install the scan head with or without the power disconnected from the interface module. (See *Installing the Scan Head in Chapter 3.*)

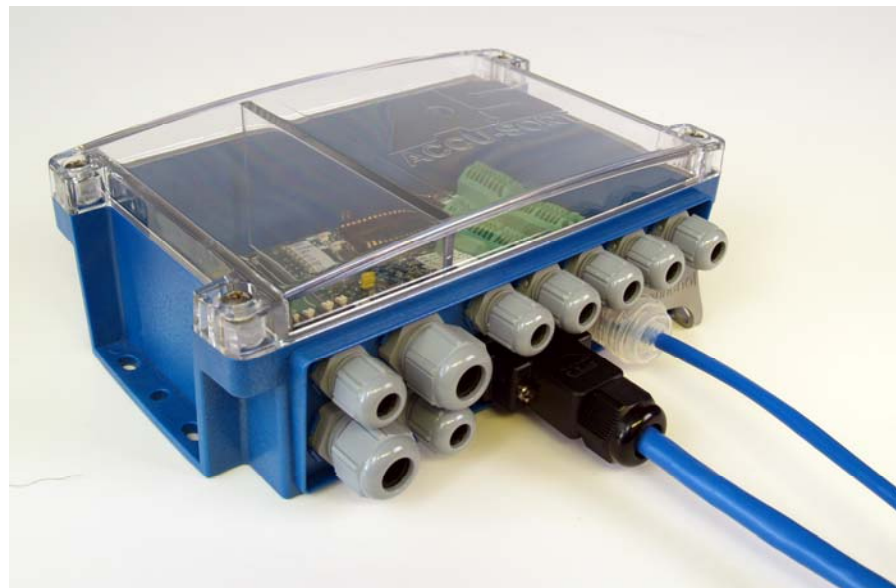

Wiring to the AL5010 without an Interface Module

CABLE NO.	WIRE INSULATION COLOR (SOLID/STRIPE)	WIRE GAUGE - AWG	DIM "W"	CONNECTOR "B" ITEM 8 PIN NO.	CONNECTOR "A" ITEM 6 PIN NO.	(WIRE NAME)	(WIRE FUNCTION)
CABLE ITEM 2	WHT/ORG	24			1	ETXP	Ethernet Transmit (TX)
	ORANGE	24			2	ETXN	Ethernet TX Compliment
	WHT/GRN	24			3	ERXP	Ethernet Receive (RX)
	GREEN	24			6	ERXN	Ethernet RX Compliment
CABLE ITEM 1	WHT/BLUE	24	7,9[3,1]	1	COM2RXP	RS422 Interface Box RX [Scan Head TX]	
	BLUE	24		6	COM2RXN	RS422 Interface Box /RX [Scan Head /TX]	
	WHT/BRN	24		2	COM2TXP	RS422 Interface Box TX [Scan Head RX]	
	BROWN	24		7	COM2TXN	RS422 Interface Box /TX [Scan Head /RX]	
	WHT/GRY	24		3	COM1TX	RS232 Scan Head TX [Interface Box RX]	
	GRAY	24		8	COM1RX	RS232 Scan Head RX [Interface Box TX]	
	WHT/YEL	24		4	TACHP	Tachometer Input	
	YELLOW	24		9	TACHN	Tachometer Return	
	WHT/PUR	24		5	TRIGP	Trigger Input	
	PURPLE	24		10	TRIGN	Trigger Return	
	PINK	22	61[2,4]	11	VDCIN	DC Power Supply Input	
	WHT/BLK	22		12	GND	DC Power Supply Return	
	RED	22		13	VDCIN	DC Power Supply Input	
	BLACK	22		14	GND	DC Power Supply Return	
	UNINSULATED	20	15 AND CASE, SEE DETAIL			DRAIN	Safety Ground

AL5010 Pin-Out Table

See also: Drawing 113493 in Appendix F.

Check Installation

After completing the installation of your AL5010:

- Confirm that the reader has been properly installed mechanically and electrically. Use the *Installation Sequence* at the beginning of this chapter and your application specifications to check your installation.
- Configure the reader's parameters to meet the needs of your application. (See Chapter 5 and online help for details.)
- See Chapter 5 and 6 for details regarding **first-time startup** and an **operations checklist**.

Check installations using Basic Interface Module:

1. Apply power to the interface module.
2. Check the following:
 - Power 'on' (POWER LED)
 - Trigger photoeye operation (TRIGGER LED)
3. Finger-tighten all water-tights.
4. Install cover.
5. Tighten four Phillips screws.
Do not over tighten.

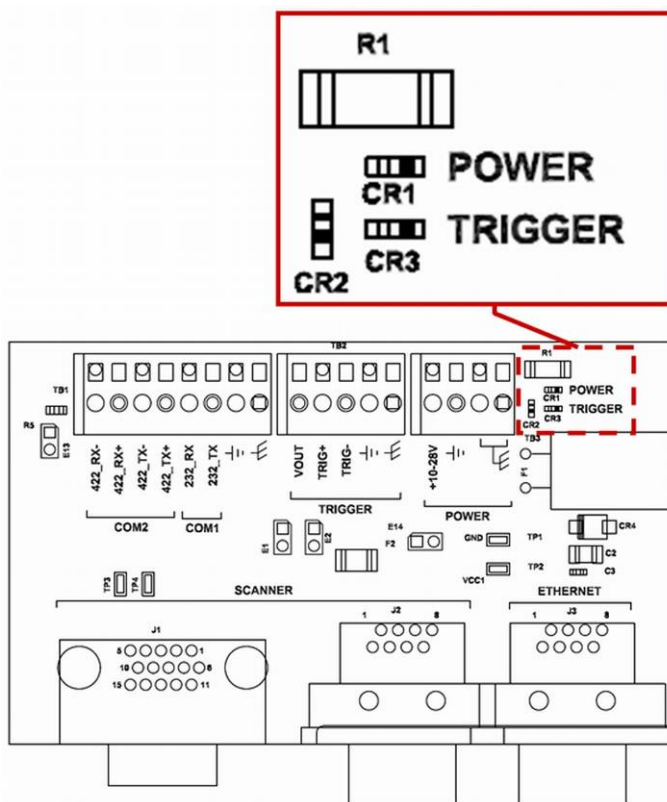

Check installations using Enhanced Interface Module:

1. Plug in the power supply.
2. Check the following:
3. Power 'on' (POWER LED)
 - Trigger photoeye operation (TRIGGER LED)
 - Tachometer operation (TACH LED)
 - Serial communications, receive data (RX1, RX2 LEDs)
 - Input Relay (if applicable, I/O 1 LED).
4. Finger-tighten all water-tights.
5. Install cover.
6. Tighten four Phillips screws.
Do not over tighten.

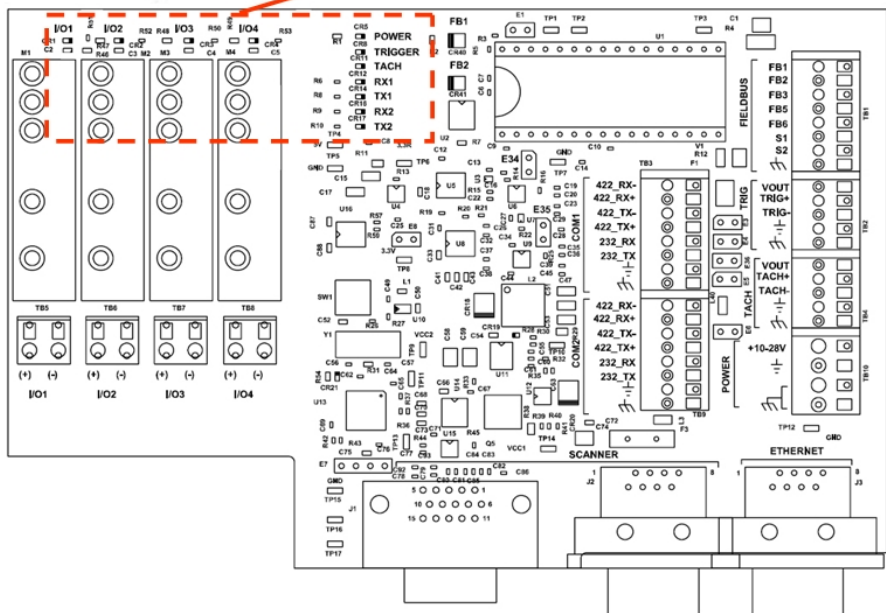
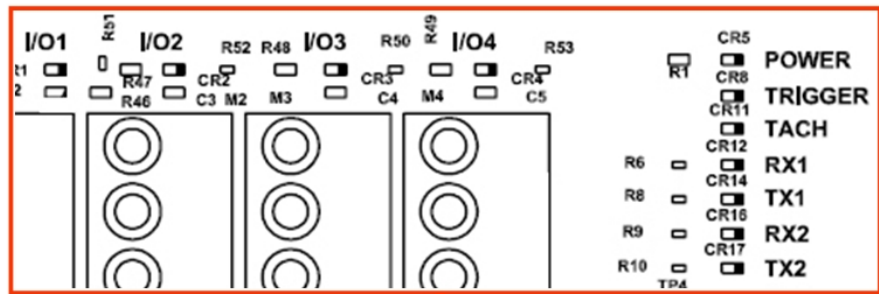

5 Setup

Getting Started

The AL5010 line of laser bar code readers is designed for ease-of-setup, allowing you to program a reader to fit your application seamlessly.

AccuLazr™ User Interface for AL5010 is a browser-based application. It is the tool you will use to define operating parameters, determine bar code read quality, and construct output messages, including filtering, stripping and padding capabilities. AccuLazr User Interface enables you to easily configure, fine-tune, and monitor your AL5010's operations.

AccuLazr User Interface provides ease-of-use for any operator level. A beginner operator follows basic setup procedures for a standard configuration. More experienced operators may use the advanced setup features that allow access to more complex options.

Prerequisites

Before setting up your AL5010 will need the following:

- **Computer:** Laptop or desktop
- **Browser:** Internet Explorer 7 or Firefox 3.6 (or later)
- **Java:** Version 6.0.210 (or later)

Starting the AccuLazr User Interface

To start the AccuLazr™ User Interface software in the Windows environment:

1. Open your web browser and enter the IP address for your AL5010 unit. If the correct IP address is entered, the AL5010 Login screen will appear (If you don't know the IP address, see *Discovering the IP Address in Chapter 8.*)

The default IP address is: 192.168.3.100

2. Enter the User ID and Password for your system in the fields provided.
3. Click **Log On**. The Home screen appears.

AccuLazr User Interface Basics

AccuLazr™ User Interface Menu Tree

The functions that you can select are displayed in a navigation list on the left-hand side of the AccuLazr™ User Interface. The function list is organized much like the hierarchy of a file system, where you can expand items that begin with a plus sign (+) to further sub-levels until you find a function of interest.

Sub-levels appear indented below the items from which they are expanded. Items that are expanded are preceded by a minus sign (-). You can expand no further when an item displays neither a plus or minus sign.

The AccuLazr™ User Interface menu tree appears with no items expanded. Click the folders to display the active window for the setup function and/or expand the folders to view any additional setup features.



Getting Help

AccuLazr™ User Interface provides complete online help.

To display help for a current window:

Choose **Help Index** from the Help drop-down menu or press the  icon at the top of the screen. A help window appears, providing you with information and an index of topics associated with the current application window.

Click on a topic of interest to display more detailed information.

You can use the menus or buttons in the help window to navigate to other topics of interest, or from the **File** menu in the help window, you can choose **Exit** to quit from Help.

Modify Settings

Use the Modify Settings menu tree selections during initial setup to configure your AL5010 Laser Bar Code Reader. If necessary, you can later make modifications to the reader's configuration using the same menu selections, including:

- Configuration
- Bar Codes / Bar Code Groups
- Modulo Checks
- Stripping and Padding
- Match Codes
- Serial Communications
- Network Communications
- Message Definitions
- Trigger
- Relay
- Tracking
- FAST Monitor Setup
- Advanced Settings
- Raster

Modify Settings > Configuration

Use Configuration to identify and configure an AL5010 bar code reader. This includes access to reader information as well as configuration options (scan rate, control panel and network access).

To set the reader Configuration:

1. Click in the Reader Name entry field and enter a unique reader name up to 15-characters in length. Use of unique reader names is especially useful in multiple scanner applications.
2. Adjust the scan rate, if necessary.
3. Enable Trigger/Track Controlled Laser, if required by your application.
4. Set the Units of measure for either ENGLISH or METRIC.
5. Assign a unique Username and Password.
6. Click **Update**.



CAUTION: Changing the scan rate can adversely affect reader performance. Do not change the scan rate unless instructed to do so by Accu-Sort Technical Support.

See also: **Modify Settings > Configuration** in Appendix C.

Modify Settings > Bar Codes

Use Bar Codes to define the symbologies the AL5010 should read for your application. Modulo check verification within a bar code can also be specified. Create bar code groups, if needed.

Bar Code Groups

When more than one bar code type is in the Selected Symbologies list, the Bar Code Groups tab is available. This enables you to define the valid “groups” of bar codes that are to be transmitted together.

For example, in the **Modify Settings > Bar Codes, Bar Code Group** tab shown here, the reader is configured to transmit EITHER:

- **Group 1:** a code 128 bar code, or
- **Group 2:** both an Interleaved 2 of 5 code and a Code 39 code.

Groups No.	Code 128	Interleaved 2 of 5	Code 39
1	<input checked="" type="checkbox"/>	<input checked="" type="checkbox"/>	<input type="checkbox"/>
2	<input type="checkbox"/>	<input checked="" type="checkbox"/>	<input checked="" type="checkbox"/>
3	<input type="checkbox"/>	<input type="checkbox"/>	<input type="checkbox"/>
4	<input type="checkbox"/>	<input type="checkbox"/>	<input type="checkbox"/>
5	<input type="checkbox"/>	<input type="checkbox"/>	<input type="checkbox"/>
6	<input type="checkbox"/>	<input type="checkbox"/>	<input type="checkbox"/>
7	<input type="checkbox"/>	<input type="checkbox"/>	<input type="checkbox"/>
8	<input type="checkbox"/>	<input type="checkbox"/>	<input type="checkbox"/>
9	<input type="checkbox"/>	<input type="checkbox"/>	<input type="checkbox"/>
10	<input type="checkbox"/>	<input type="checkbox"/>	<input type="checkbox"/>
11	<input type="checkbox"/>	<input type="checkbox"/>	<input type="checkbox"/>
12	<input type="checkbox"/>	<input type="checkbox"/>	<input type="checkbox"/>
13	<input type="checkbox"/>	<input type="checkbox"/>	<input type="checkbox"/>
14	<input type="checkbox"/>	<input type="checkbox"/>	<input type="checkbox"/>
15	<input type="checkbox"/>	<input type="checkbox"/>	<input type="checkbox"/>
16	<input type="checkbox"/>	<input type="checkbox"/>	<input type="checkbox"/>

To add a bar code using Learn Bar Code:

1. Click **Learn**. The Bar Code Learn screen is displayed.
2. Hold the bar code (as illustrated in the user interface) within the reader's depth of field. The reader will attempt to read the bar code for three minutes to 'learn' all codes in the scan line. After three minutes, the reader will stop the learn operation. If necessary, click **Cancel Learn** to stop Learn Bar Code.



NOTE: When one code is in the scan line, it must be saved after Learn before another code can be “Learned.”

3. Once the reader has finished ‘learning’ it displays a list of all codes including the code data.
4. If no codes are found within three minutes, the Learn Bar Code function will end.
5. Use the checkboxes to select any of the codes learned to the **Selected Symbologies** list.

Click ‘Add’. The codes will be added to the **Selected Symbologies** list.



NOTE: The reader can learn multiple bar codes appearing in the scan line at the same time.

REMEMBER: These 'learned' codes that are added to Selected Symbologies will only be added to the reader's functional parameters after clicking Update. Use the Save to Reader function (found on the Save/Retrieve screen) to save the parameters for continuous use.

To add a bar code manually:

1. To add a bar code, go to the Modify Settings > Bar Code screen.
2. Be sure you know the parameters for the symbology you are adding to your active list.
3. Select the symbology from the Code Type drop-down list.
4. Assign a unique Code Label, if necessary.
5. Define the minimum and maximum code length.
6. Define the minimum and maximum quantity.
7. Select the Modulo Check.
8. Enter a Filter, if required.
9. Click **Add**. The code added will appear in the Selected Symbologies list highlighted in yellow.
10. Click **Update**.

To edit a bar code:

1. To edit a bar code, go to the **Modify > Bar Code** screen.
2. Select an option button to highlight any Symbology listed under Selected Symbologies that you want to edit.
3. To change any of the settings (e.g. Code Label, Min/Max Length, Min/Max Quantity, Modulo Check, Extension), click in the field and make the required changes.
4. Click **Update** and then click the save icon ().

To move a bar code:

5. To move a bar code, go to the **Modify > Bar Code** screen.
6. Select an option button to highlight any Symbology listed under Selected Symbologies that you want to move.
7. Click **Move Up** to move the selected bar code toward the top (beginning) of the list.
8. Click **Move Down** to move the selected bar code further back (toward the end) of the list.
9. Any changes are highlighted in the list.
10. Click **Update** and then click the save icon ().



NOTE: Bar code data is transmitted in the order that they appear in the Selected Symbologies list.

To remove a bar code:

1. To remove a bar code, go to the **Modify > Bar Code** screen.
2. Select an option button to highlight any Symbology listed under Selected Symbologies that you want to remove.
3. Click **Remove** to delete the selected bar code from the list.
4. Click **Update**.

To create a bar code group:

1. Go to the **Bar Code Groups** tab.
(This tab becomes available when two or more codes are available under Selected Symbologies.)
2. Create Group 1 by clicking the checkbox for the codes to be included in the group.
3. Create any additional groups required.
4. Click **Update**.

See also: **Modify Settings > Bar Codes** in *Appendix C*.

Modify Settings > Modulo Checks

Use the Modulo Checks screen to setup the user defined modulo checks for any bar code symbologies that you have specified need them. If you selected a User Defined Modulo Check while in the **Modify Settings > Bar Codes** setup screen, you will need to define it on the Modulo Checks screen.

To set a user defined modulo check for a bar code:

If a bar code requires a User Defined Modulo Check as defined on the Bar Codes page, go to the **Modify Settings > Modulo Checks** page.

1. Find the correct modulo check row (i.e., User Defined 1 through 5) for the code.
2. Set the Factor.
3. Set a Divisor.
4. Select Remain, if required.
5. Select Right, if required.
6. Select Wrap, if required.
7. Repeat as necessary for all codes with a user defined modulo check.
8. Click **Update**.

See also: **Modify Settings > Modulo Checks** in Appendix C.

Modify Settings > Stripping/Padding

For each symbology type (defined in **Modify Settings > Bar Codes**), stripping and/or padding of the bar code data can be specified. This stripping and padding is applied to the bar code before any message formatting.



NOTE: Character stripping is applied before character padding.

To set the character stripping for a bar code:

1. Select the bar code from the Available Bar Codes drop-down list.
2. Click on the required character stripping option.
3. Proceed to character padding if required.
4. Click Update when finished.

To set the character padding for a bar code:

5. Select the bar code from the Available Bar Codes drop-down list.
6. Click on the required character padding option.
7. Make the necessary entry based on the padding option selected.
8. Click Update.

See also: **Modify Settings > Stripping/Padding** in Appendix C.

Modify Settings > Match Codes

Use **Modify Settings > Match Codes** to define a specific code pattern within a symbology type that is to be considered a "match condition".

In addition to identifying and reading a symbology you defined (using **Modify Settings > Bar Codes**), this feature enables you to configure a reader to match specific select characters within a bar code.

All bar codes are compared to the complete list of Match Codes. If a bar code matches ANY of the codes defined in Match Code settings, it is considered a MATCH. When a match code is read, you can setup your reader to:

- fire a relay output (Example: Activate a diverter)
- send a user-defined message (Example: Acknowledge match code found)

The following wildcards are available:

- "*" represents a string with arbitrary length
- If you enter 9* and the AL5010 reads bar code data 91234567890, then the AL5010 will transmit a valid read to the host because the leading 9 matches the pre-defined match character. The rest of the characters in the bar code are not effected because the asterisk wildcard instructs the AL5010 that the 9 is the only character that need to be matched.
- If the AL5010 reads bar code data 01234567890 then the AL5010 will transmit a no read because the leading 0 in the bar code did not match the pre-define 9.
- "?" represents a single character
- With this condition, the AL5010 will ignore the character located in the designated location in the data string and only match the identified data.

See also: **Modify Settings > Match Codes** in Appendix C.



NOTE: If ANY match code pattern is set to "*" ALL codes will match it.

Modify Settings > Serial Communications

Use the Serial Communications menu tree selections to set the serial port connection parameters including:

- Baud Rate
- Data Bits
- Stop Bits
- Parity
- Flow Control
- Message Format

Individual settings can be made for Serial Port 1 and Serial Port 2. If the User Defined Message format is selected, an addition tab screen is supplied for creating unique message definitions.

Serial Port 1 and 2

Use **Modify Settings > Serial Communications > Serial Port 1** (or 2) to define the format of message the reader sends to your host computer (or other device) connected to Serial Port 1 (or 2).

To set or modify the communications parameters for Serial Port #1:

1. Go to the Serial Communications Port#1 screen.
2. Click a Baud Rate option group button.
3. Click a Data Bits option group button.
4. Click a Stop Bits option group button.
5. Click a Parity option group button.
6. Click a Flow Control option group button.
7. Select a Message Format from the drop-down list.
8. Click **Update**.

Message Definitions

When any option, other than the Standard Message selection, under the Message Format item is selected a Message Definition tab is made available.

Creating User-defined Messages



NOTE: Use the same procedure to create user-defined messages for both the serial (Modify > Serial Communications Port #1 or Port #2) and network communications (Modify > Network Settings).

To create user-defined messages:

Under Message Format, select **User Defined Message**.

A Message Definitions tab becomes available. For the serial port, select Message Definitions – Port #1(or 2) (example shown below). For network communications, select Message Definitions – Net#1(or 2).

To define message framing:

Header - Character string specified for the header. Sent at beginning of every message.

Trailer - Character string specified for the trailer. Use to terminate every message.

Seq # - When enabled, a sequence number consisting of the specified number of digits is inserted just after the header.

Check Digit - When enabled, a two-character hexadecimal check character is inserted just prior to the trailer.

Include Multi-Bar code in single message (checkbox) - Affects how the reader handles multiple bar code transmissions. If enabled, the bar codes are sent in one message (between one header and trailer) and each bar code is separated by the specified "separator." If disabled, all bar codes are always sent as a complete message (with a header and trailer).

Bar Code Separator - String used to separate multiple bar codes (see above).

Power Up/Connect Message - String that is always sent on reader initialization. Note that for a Network connection, this string is always sent when the socket connection is made.

To define Serial Port 1 message content:

The message drop-down lists define the message options for each bar code. The message content can be defined for transmissions from the reader's serial port #1 as well as any network connection (via Net#1). These messages are based on various conditions. For each condition, there are options for what message can be sent. These options include:

Send Bar Code - Bar code (with padding and/or stripping) is sent.

Repeat Character - Send a message consisting of the specified character repeated for the minimum number of characters for the bar code (example is "???????" no-read message).

User Specified Message - Send a message defined string for this condition.

Category 1: Read, No Read, or Multiple Bar Code

These three conditions are mutually exclusive, so only one of these three messages can be sent for any bar code.

Read - If disabled, nothing is sent for a valid read; otherwise either the bar code or a user specified message is sent.

No Read - If disabled, nothing is sent for a no-read; otherwise either the specified "repeated character" or the user specified message is sent.

Multiple Bar Code - If disabled, a multiple bar code condition will be reported as a "Read" of the first bar code reported. Otherwise, the specified "repeated character" or the user-specified message is sent.

Category 2: Match, No Match, No Match Read

These conditions are IN ADDITION to the conditions specified in Category 1. If a condition in both categories is met, these messages will be appended. If you desire to only generate a message based on Category 2 conditions, all messages in Category 1 should be disabled.

Match - If the bar code matches any of the match codes, this message is sent. Options include sending the bar code or a user specified message.

No Match - If the bar code does not match any of the match codes (or was a no-read), this message is sent. Options include sending a "repeated character" or a user specified message.

No Match Read - If a valid bar code was read, but it does not match any of the match code, this message is sent. Options include sending the bar code or a user specified message.

Category 3: Append QQ, Heart Beat Message, and Heart Beat Timeout

Append QQ (code quality) to message (checkbox) - When selected a two digit "code quality" indication (number from 00 to 99) is appended to the bar code message. The code quality value is separated from the message with the specified separator.

Heart Beat Message - When enabled, if no other message is sent for the time period specified in Heart Beat Time Out, the specified heart beat message string is sent. A time-out of zero disables the heart beat message.

Heart Beat Time Out (0-30,000 ms) - 0 = Disable Heart Beat Message, 1-30,000 = Delay before sending Heart Beat Message

Append Distance to Message - allows the AL5010's measured approximate distance from the scanner to the bar code read to be in the transmitted message.

See also: **Modify Settings > Serial Communications** in Appendix C.

Modify Settings > Network

Use **Modify Settings > Network** to specify network settings (including the IP address) for the reader. Currently, the reader can only be configured to use a Static IP address. Net Host Port1 and Net Host Port2 define two network connections for sending bar code messages. The Connection Type and Message Format for each port can be set independently. Message formatting is the same as for the serial port.

- **IP Address** - An IP address specifies a unique host ID for the reader on a particular TCP/IP network. Consult your network administrator for a valid IP address for the reader.
- **Net Mask** - A netmask modifies a standard IP address into subnets. A default net mask should be valid in most cases (255.255.255.0). Consult your network administrator for the net mask value.
- **Gateway IP Address** - A gateway allows the reader to reach other systems not on the local network and remote systems to reach the reader. If the reader requires external connectivity, consult your network administrator for a valid gateway address.

Net Host Port 1 or 2

Connection Type

The following connection types are available for each network port:

- **TCP/IP Server:** As a TCP/IP server, a Port # must be specified. In this case it is the TCP/IP client's responsibility to initiate a reader connection.
- **TCP/IP Client:** As a TCP/IP client, aside from the Port #, the Remote IP Address of the TCP/IP server which is to receive the barcode messages must be specified. The Reconnect Time specifies the interval (in seconds) at which the reader attempts to establish a connection.
- **UDP Messaging:** In some instances, it may be desirable to use a connectionless UDP message to send bar code data. In this case, only the Port # and Remote IP Address of the receiver need to be specified.
- **EtherNet/IP (Net Host Port 1 only):** This enables use of the EtherNet/IP protocol on the reader.
- **Message Format** - There are four message format options: Custom Message, Standard Message, User Defined Message, and MUX (ADP) Message.

Controller/Client Configuration

Number of Client Readers - The number of client readers in a multi-reader network must be defined on the reader acting as the Controller. Drop-down list selectable for up to 14 readers functioning as "Clients". Client readers must be set at zero (0).

Group Number - All readers in a Controller/Client group (both the Controller and ALL Clients) must be set to the same controller group number. The default of zero (0) disables a reader from listening for messages to become a client.

Ethernet Link

Drop-down list with 5 selections: AutoDetect, 100 Mbps/Full Duplex, 100 Mbps/Half Duplex, 10 Mbps/Full Duplex, 10 Mbps/Half Duplex

- **Controller Multicast IP Address:** This is the IP address used by this controller to communicate to its Group (Identified by the Group No.) to broadcast such messages as tach and trigger.



NOTE: This IP address should not be changed.

- **Telnet Port:** The port number used to Telnet into the AL5010.

Message Definitions

Whenever you specify a user-defined message format for either serial port #1 or network settings, Message Definitions become available

Creating User-defined Messages



NOTE: Use the same procedure to create user-defined messages for both the serial (Modify > Serial Communications Port #1) and network communications (Modify > Network Settings).

To create user-defined messages:

Under Message Format, select User Defined Message.

A Message Definitions tab becomes available. For the serial port, select Message Definitions – Port #1 (example shown below). For network communications, select Message Definitions – Net#1.

To define message framing:

Header - Character string specified for the header. Sent at beginning of every message.

Trailer - Character string specified for the trailer. Use to terminate every message.

Seq # - When enabled, a sequence number consisting of the specified number of digits is inserted just after the header.

Check Digit - When enabled, a two-character hexadecimal check character is inserted just prior to the trailer.

Include Multi-Bar code in single message (checkbox) - Affects how the reader handles multiple bar code transmissions. If enabled, the bar codes are sent in one message (between one header and trailer) and each bar code is separated by the specified "separator." If disabled, all bar codes are always sent as a complete message (with a header and trailer).

Bar Code Separator - String used to separate multiple bar codes (see above).

Power Up/Connect Message - String that is always sent on reader initialization. Note that for a Network connection, this string is always sent when the socket connection is made.

To define Serial Port 1 message content:

The message drop-down lists define the message options for each bar code. The message content can be defined for transmissions from the reader's serial port #1 as well as any network connection (via Net#1). These messages are based on various conditions. For each condition, there are options for what message can be sent. These options include:

Send Bar Code - Bar code (with padding and/or stripping) is sent.

Repeat Character - Send a message consisting of the specified character repeated for the minimum number of characters for the bar code (example is "???????" no-read message).

User Specified Message - Send a message defined string for this condition.

User Specified Message - Send a message defined string for this condition.

Category 1: Read, No Read, or Multiple Bar Code

These three conditions are mutually exclusive, so only one of these three messages can be sent for any bar code.

Read - If disabled, nothing is sent for a valid read; otherwise either the bar code or a user specified message is sent.

No Read - If disabled, nothing is sent for a no-read; otherwise either the specified "repeated character" or the user specified message is sent.

Multiple Bar Code - If disabled, a multiple bar code condition will be reported as a "Read" of the first bar code reported. Otherwise, the specified "repeated character" or the user-specified message is sent.

Category 2: Match, No Match, No Match Read

These conditions are IN ADDITION to the conditions specified in Category 1. If a condition in both categories is met, these messages will be appended. If you desire to only generate a message based on Category 2 conditions, all messages in Category 1 should be disabled.

Match - If the bar code matches any of the match codes, this message is sent. Options include sending the bar code or a user specified message.

No Match - If the bar code does not match any of the match codes (or was a no-read), this message is sent. Options include sending a "repeated character" or a user specified message.

No Match Read - If a valid bar code was read, but it does not match any of the match code, this message is sent. Options include sending the bar code or a user specified message.

Category 3: Append QQ, Heart Beat Message, and Heart Beat Timeout

Append QQ (code quality) to message (checkbox) - When selected a two digit "code quality" indication (number from 00 to 99) is appended to the bar code message. The code quality value is separated from the message with the specified separator.

Heart Beat Message - When enabled, if no other message is sent for the time period specified in Heart Beat Time Out, the specified heart beat message string is sent. A time-out of zero disables the heart beat message.

Heart Beat Time Out (0-30,000 ms) - 0 = Disable Heart Beat Message, 1-30,000 = Delay before sending Heart Beat Message

See also: *Modify Settings > Network in Appendix C.*

Modify Settings > Trigger

The trigger helps the reader identify when products with bar codes are entering the scanning area. Use **Modify Settings > Trigger Settings** to set the various trigger parameters.

Trigger Source

There are three options for trigger source:

- Hardware Trigger
- Software Trigger
- Continuous Trigger

Since the trigger parameters vary based on trigger type selected, the trigger parameter options have been defined within the context of the specific trigger source.

See also: **Modify Settings > Trigger** in *Appendix C*.

Modify Settings > Relay

Use to define functionality of any I/O relay module options utilized by your reader. *For additional information and field descriptions, see **Modify Settings > Relay** in Appendix C.*

To configure an I/O relay:

1. Select the intended use of the relay (output or input).
2. Select the intended purpose for the relay.
3. Set for either Active High or Active Low.
4. For relay outputs, set an output signal duration.
5. After configuring the relays, click **Update**.

Modify Settings > Tracking

Use tracking in application that require:

- Tight package spacing
- Transmit point is greater than the "smallest box + minimum box spacing" distance.

Use **Modify Settings > Tracking** to define all of the parameters associated with monitoring package travel on the conveyance system. The tracking parameters are only available if tracking is enabled, otherwise they are not shown in this window.

To enable tracking:

1. Click in the Tracking Enabled checkbox. When tracking is enabled, a checkmark appears in the checkbox and the tracking parameter settings are visible in the **Modify Settings > Tracking** screen.
2. Adjust the tracking settings for Tachometer (Encoder), Reader Mounting, Transmit, and Tracking Configuration.
3. Click **Update**.

See also: **Modify Settings > Tracking** in Appendix C.

Modify Settings > FAST Monitor™

FAST Monitor is a browser-based application, running on a FAST Monitor Server, that gives facility managers and maintenance personnel the ability to monitor multiple Accu-Sort products within their facility or across multiple facilities from anywhere an internet connection is available. FAST Monitor provides real time and historical performance data in an easy to use browser interface as well as automatic status and error condition reporting of all Accu-Sort products and systems to which it is connected.

Use the FAST Monitor screen to configure an AL5010 reader for FAST Monitor message format compatibility. *For additional information and field descriptions, see **Modify Settings > FAST Monitor** in Appendix C.*



NOTE: For more information on FAST Monitor functionality, see the FAST Monitor Product CD, online help or contact us at 1-800-BAR-CODE.

To Configure an AL5010 reader for FAST Monitor messaging:

1. On the **Modify Settings > Configuration** screen, confirm a unique Reader Name is set.
2. On the **Modify Settings > Network** screen, confirm the reader is properly set as either the Controller or a Client.
3. Go to the Modify Settings > FAST Monitor screen.
4. Under Tunnel Information, assign a Tunnel Name.
5. Select the Reader Position from the drop-down menu. Reference the illustration for relative positions.
6. If the reader is a standalone unit or controller in a scanning tunnel, be sure to set the FAST Monitor Port information. The Port No. is always 9899.



IMPORTANT: Be sure to use a unique position that relates to the reader's location in the scanning tunnel. Avoid assigning the same Reader Position to two different readers.

See also: **Modify Settings > FAST Monitor** in Appendix C.

Modify Settings > Advanced

The **Advanced** screen provides filters for enhancing the scanners ability to read a bar code. Adjusting these values may have a negative or positive effect on the reader's ability to decode a bar code.

The Data Filtering, DRX (Data Reconstruction) and Transmit QQ settings are considered advanced settings because they require comprehensive training to understand how they should be modified.



NOTE: Changing the Advanced settings can adversely affect reader performance. These settings are to be modified only under the guidance of Accu-Sort Technical Support.

Data Filtering			
Scan Filtering (Skip Scan)	<input type="text" value="0"/>	Minimum Transitions	<input type="text" value="6"/>
Laser 1 DOF: Near Dist (in)	<input type="text" value="3.0"/>	Far Dist (in)	<input type="text" value="45.0"/>
Laser 2 DOF: Near Dist (in)	<input type="text" value="0.0"/>	Far Dist (in)	<input type="text" value="38.0"/>
Bar Code Size			
Scan Rate	<input type="text" value="1000"/>	Field of View	<input type="text" value="54"/>
Min Narrow Element (mils)	<input type="text" value="10"/>	Max Narrow Element (mils)	<input type="text" value="13"/>
Maximum Tilt	<input type="text" value="45"/>		
DRX Setting			
<input checked="" type="checkbox"/> DRX Enabled			
Overlay Ratio	<input type="text" value="65"/>	Radio M Factor	<input type="text" value="14"/>
Win.	<input type="text" value="4"/>	Max Recurse	<input type="text" value="1"/>
Pairs	<input type="text" value="6"/>	Kill Limit	<input type="text" value="5"/>
Change	<input type="text" value="600"/>	Overlay	<input type="text" value="2"/>
Search (0.0-3.0)	<input type="text" value="0.50"/>	<input checked="" type="checkbox"/> Overlay Recover Enabled	
<input type="button" value="Default DRX"/>			
Transmit QQ			
Minimum QQ	<input type="text" value="3"/>	Maximum QQ	<input type="text" value="200"/>
<input type="button" value="Update"/> <input type="button" value="Reset"/>			

Data Filtering

The data filtering parameters specify the minimum and maximum pulse width (in counts) for the bar code data. This important data filter setting assures optimal reader performance. The Sampling Frequency default of 100 Mhz assures better decoder resolution for poorly printed bar codes.

Scan Filtering (Skip Scan) –

- This option is used on applications that have slow conveyance and/or reading bar codes with a large bar height. Under these conditions the reader fills its memory with so much data that it does not have time to process all the data before the end of trigger, causing the reader to no-read. The Scan Filtering (Skip Scan) option limits the amount of data, allowing the reader to processing less data and give it a more of an opportunity to read the bar code.

Minimum Transitions –

- There have to be a certain number of bars and spaces detected on a scan line in order to consider the information valid. This option restricts data from being placed into memory.

- Should be at least as long as Start/Stop character. If short Start/Stop character, use the length of one data character plus the start/stop character (e.g.;12 of 5)
- In this subroutine, any group of elements less than the min trans setting is discarded or ignored.

Laser /Laser 2 DOF: Near Dist (in)/Far Dist (in)

- These options filter out any transitions beyond the entered values. Any transition (including bar codes) seen beyond these values are not placed into memory to be processed by the reader.

This also includes valid bar codes.

- As an example the above view shows the closest a bar code can be processed is six inches for Laser 1 and 27 inches for laser 2. Any bar code found closer then these values will be filtered out and the reader will report a No-Read.

Bar Code Size

- Min Narrow Element (mils)/Max Narrow Element (mils)/Maximum Tilt
- These entries are used to identify valid Quite Zones.

DRX Settings

The DRX settings typically will not need to be modified.

Transmit QQ

The Minimum QQ is the smallest allowable QQ value for a code to be transmitted.

The Maximum QQ forces the transmission of a code after the maximum QQ value is reached.

See also: **Modify Settings > Advanced in Appendix C.**

Modify Settings > Raster

Use **Modify Settings > Raster** to define the laser sweep area of an AL5010 with the optional adjustable raster feature. It also allows you to set the oscillating frequency (speed) of the vibrating mirror.

The sweep of the laser is determined by the amount of coverage your application requires (possible label position) and the distance of the laser scanner from the object being scanned. The laser sweep is adjustable from 20-degrees above 0 (the center laser position) or -20-degrees below 0.

Examples:

- If the **Upper Sweep** is set to 15-degrees and the **Lower Sweep** is set to 10-degrees, the total coverage will be 25-degree encompassing 0.
- If the **Upper Sweep** is set to -5-degrees and the **Lower Sweep** is set to -15-degrees, the total coverage will be 10-degrees, but below the 0 position.
- If the **Upper Sweep** and **Lower Sweep** are both set to -10 degrees, the laser will remain static at 10-degrees below the 0 position.

To Set the Sweep of the Laser:

1. Enter a value in the **Upper Sweep** text field between -20 and 20.
2. Enter a value in the **Lower Sweep** text field between -20 and 20.
3. Click **Update**.

To Set the Oscillating Frequency:

1. Enter a value in the Oscillating Frequency text field between 0 and 4. A value of 0 will stop oscillation, while values above 0 will increase the speed of the oscillation up to the fastest at a value of 4.
2. Click **Update**.

See also: **Chapter 3: Mechanical Installation > Raster Setup**.

Save / Retrieve

Use Save/Retrieve to save all the settings to the scan head and backup the settings to the mounting base and/or file.

To use the save/retrieve functions:

1. Select an Action.
Based on the action selected, either the From or To drop-down list becomes available.
2. Select the required location (either From or To).
3. Follow any additional prompts.
For example: If Retrieve from File is selected, use the Browse function provided to locate the file.
4. Click **OK**.

Default

Use to return the reader's parameters to the hard-coded "default" values built into the reader software.



USEFUL TIP: Selecting Default will return your reader to the default factory settings. Since your reader may already be configured for your application, it is recommended that you ALWAYS Save to Disk before using the default function.

Retrieve from Base

Use to retrieve the parameters stored in the reader's mounting base. This is especially useful when it becomes necessary to load the correct parameters to a replacement reader module.

Retrieve from File

Use to retrieve a parameters set from a specific file name and location on your computer.

Save to Base

Use to save the current set of parameters to the mounting base as a backup copy.

Save to File

Use to specify a file name and location to store the current parameter settings on your computer.

Save to Reader

Use to save the current set of parameters to the reader. Parameters saved in the reader are the parameters used during normal operations.

Reboot AL5010

Click Reboot to reinitialize the scanner.

See also: **Save / Retrieve** in *Appendix C*.

Diagnostics

The AL5010 includes comprehensive diagnostic that enable you to monitor:

- Status LEDs
- Read Quality
- Messages
- Box Information
- Message Monitor
- Read Rate Log
- Counters Log
- Message Log
- Upload Firmware

Diagnostics > Monitor

Use the **Diagnostics > Monitor** as the primary tool to monitor the reader's operation and bar code readability in real-time. Status indicators and vital statistics appear on a single screen, enabling you to effectively and efficiently detect and troubleshoot any problems that may occur.



The Monitor is a Java application and requires Java and the appropriate browser plug-in.

See also: ***Diagnostics > Monitor*** in *Appendix C*.

Diagnostics > Log Viewer

The **Diagnostics > Log Viewer** lets you review the performance logs saved by the reader. The three most commonly viewed logs are available by selecting one of the three buttons:

- Read Rate
- System Counters
- Message Log

You can also enter a log request in the **Command** field. For example: **DISPENET** will provide Ethernet data.

The log view field remains empty until you select a button or enter a command.

To determine which log is currently being shown in the log viewer, the log's name is shown just below the words log view in the window.

For additional information and field descriptions, see **Diagnostics > Log Viewer** in Appendix C.

To use commands to view a log:

1. Enter a command in the Log Viewer Command field without using spaces (i.e., DISPCOUNTERS, DISPMSGLOG, etc.)
2. Click Send Command.
3. Log Viewer displays the most current information for the log you requested.
4. Click **Clear** to empty the Log Viewer.

Read Rate Log View

Use the **Read Rate** Log View to see a summary of the reader's overall performance.

To open the Read Rate Log View:

1. Click **Read Rate**, or
2. Enter DISPREADRATE in the command field. Click **Send Command**.
3. The Read Rate log is shown in the viewer.
4. Click Clear to empty the viewer and display another log.

Overall Read Rate Statistics

The Read Rate Log Viewer provides information on the overall read rate.

Total Boxes	Total number of triggers.
Good Boxes	A good box is a box with all required codes. This counter is the number of good boxes along with the percentage of the total boxes that were good.
Partial Boxes	A partial box is a box where some, but not all required codes were read. This only applies when the reader is configured to read multiple codes each trigger.
Bad Boxes	A bad box is a box where no codes were read.

Read Rate Counters by Laser

The Read Rate Log Viewer also provides performance information on each laser. In order to provide diagnostics on the performance of each laser, the percentage references here are the percentage of the total codes read by the particular laser, NOT the percentage of the total packages read by that laser.

Total Codes	Total number of bar codes read.
-------------	---------------------------------

Laser#x	Total number of bar codes read by the particular laser
---------	--

For a reader configured as a Controller in a multi-reader network, this command also provides counters for the number of bar codes read, by laser, for each reader client. The clients are identified by their reader name as assigned in Modify > Configuration.



REMEMBER: Not every reader is configured with two lasers.

Counters Log View

Use the **Counters** Log View to display a number of values and counters that indicate whether the reader is configured and operating properly.

To open the System Counters Log View:

1. Click **Counters**, or
2. Enter DISPCOUNTS in the command field. Click **Send Command**.
3. The system counters log is shown in the viewer.
4. Click **Clear** to empty the viewer and display another log.

Scan Rate and Belt Speed System Counters

Scan Rate	This is the total number of scans/second that the reader is reading. Note the this number does NOT take into account "laser toggling" if it is enabled. If "laser toggling" is enabled, the effective scan rate for any laser is half of this value.
Belt Speed (Tracking)	Speed of the belt (in ft/min) as measured by the tachometer.

Bar Code System Counters

Triggers	Total number of packages based on the trigger signal. In self-trigger mode, this will match the number of good reads.
Good Reads	Total number of bar codes read and transmitted. If the reader is set up to read multiple bar codes each trigger, this counter is incremented for each bar code read.
No Reads	Total number of bar codes that were not read.
Mult Codes	Total number of instances where more bar codes of a specific type were read than expected. This counter will also increment, regardless of whether the reader is configured to report "multiple codes" as an error.
Match Codes	Total number of bar codes that matched any of the Match Code criteria.
Bad ModChk	Total number of bar codes that were rejected due to an invalid Mod Check.

Error Counters

Xfer Ovflw	Transfer Overflow. This counts the number of codes that were lost due to an overflow in the transfer buffer between the Decode/DSP processor and the reader/ARM processor.
Xfer BadLen	Transfer Bad Length. Number of codes in the transfer buffer than contained an invalid length, indicating some sort of memory corruption.
QData@TX	Queue Data at Transmit (non-tracking). This counter indicates that the reader had not completed processing all of the scan data at the user-specified transmit time. This will only happen if the "transmit time" parameter is set to a value other than zero. This does not necessarily indicate an error, but does indicate that either the transmit time is too short or the reader is seeing a lot of data which may be the result of too much background noise.
QData@Trig	Queue Data at Trigger (non-tracking). This counter indicates that the reader had not completed processing all of the scan data prior to the start of the next trigger. This typically can only happen when the "transmit time" parameter is set to zero; although it can also happen in conjunction with a Force Transmit. As with the Queue Data at Transmit counter, this does not necessarily indicate an error, but it likely indicates that the reader is seeing a lot of data which may be the result of too much background noise.
ForcedTx	Forced Transmit (non-tracking). A forced transmit indicates that the start of trigger occurred before the specified transmit delay time had expired.
Lost Codes	Lost Codes (tracking). If a bar code cannot be placed onto any package while in tracking, the code is "lost" and this counter is incremented. Lost codes are also reported in the Monitor message window. Lost code occurrences typically indicate tracking parameters need to be adjusted.
Missed Tx	Missed Transmit (tracking). If a bar code is decoded after the message for that package has been transmitted, the Missed Transmit counter is incremented.

Decode/DSP Counters

DSP Codes	Count of the number of bar codes decoded, per laser, by the DSP.
Scan Ints	Number of scan interrupts detected by the DSP.
Queue Size	Current size of the scan data queue within the DSP. This value changes dynamically.
Num Cluster	Current number of DRX clusters in use by the DSP. This value changes dynamically.
Bad Scan	Count of the number of scans in which the data contained formatting errors.
Pipe Error	Count of internal errors on the transfer of scan data from the scan data buffer.
Full Scans	Number of times a scan could not be added to the scan data buffer because the maximum number of scans was exceeded.
Mem Full	Number of times a scan could not be added to the scan data buffer because the memory was full.
ScanTooLong	Number of times a scan was skipped because it contained too many transitions.
Max Clusters	Number of times, the maximum number of DRX clusters was exceeded.

ARM and DSP Restarts Counters

ARM Restarts	Number of times the ARM processor has restarted. This typically means the hardware watchdog timer expired causing the ARM processor to restart.
DSP Restarts	Number of times the DSP processor has been restarted. Typically, this happens if the ARM suspects the DSP has "locked up" for any reason.

Message Log View

The **Message Log** View contains various text messages that have been logged by the reader software.

The messages contained in this log typically reflect significant events.

To open the Message Log View:

1. Click Message Log, or
2. Enter DISPMMSGLOG in the command field. Click **Send Command**.
3. The message log is shown in the viewer.
4. Click **Clear** to empty the viewer and display another log.

Command

There are several commands that you can use to display reader parameters and diagnostic information.

Commands can be sent from the Command field on the Log Viewer.

Commands may also be sent from a terminal interface, such as a TELNET connection to the reader.

Log Viewer Commands	Definition
CLEAR ALL	Clears all information from the Message Monitor.
DISP COUNTERS	Display the System Counter log view.
DISP ENET	Display the Ethernet interface status, including MAC address.
DISP MSGLOG	Display the Message log view.
DISP READRATE	Display the Read Rate log view.

Diagnostics > Update Firmware

Use **Diagnostics > Update Firmware** to reload the reader firmware. For additional information and field descriptions, see **Diagnostics > Update Firmware** in Appendix C.



CAUTION: This function should only be performed under the guidance of Accu-Sort Technical Support.

To Extract Image

1. Click Extract Image.
2. In Save as window, save the image (*.as) files to your computer. The graphic on-screen indicates Extract Image is in-process.



3. A message will appear when Extract Image is complete.

To Burn Flash

1. Click Burn Flash.
2. In Open window, open an image file (*.as) to burn to flash. The graphic on-screen indicates Burn Flash is in-process.



3. A message will appear when Burn Flash is complete.

6 Operations

This chapter provides details on how the AL5010 bar code scanning solutions function during normal operation. It also outlines how you can verify optimal performance through several methods:

- Become more familiar with your application
- Step-by-step start-up operations checklist
- Status Indicator LEDs
 - AL5010 Reader
 - AL5010 Interface Module
- Diagnostics to confirm normal operations

After configuring your AL5010 reader using the browser-based setup application, use the operations checklist to verify normal operations.

First-time Startup

On initial power-up, the AL5010 performs a series of self-diagnostic and LED tests. The complete power-up sequence takes less than 20 seconds.

When the STATUS LED flashes and turns a steady green the power-up sequence is complete. The AL5010 is now operational.



NOTE: When an application uses multiple AL5010 readers, you can provide each reader with a *unique* reader name using the browser-based setup application. This makes it easier to keep track of reader parameter changes when working with several readers on a network. (See *Chapter 5*.)

Default Parameters

The reader is shipped from the factory with these defaults:

- Connection Mode: Setup Cable
- Reader Name: AL5010
- Control Panel Buttons Enabled
- Code 128 (10-30 characters)
- IP address 192.168.3.100

Perform the following setup procedure using these defaults or configure your AL5010 with your application's parameters using the browser-based setup application.

First-time Setup

Every application is unique. AL5010 is designed for ease-of-setup, allowing you to program the reader to fit your application seamlessly.

A browser-based setup application on your laptop/desktop computer is the tool you will use to define operating parameters, set bar code type / length, and construct output messages, including filtering, stripping and padding capabilities. AccuLazr's user interface enables you to easily configure, fine-tune, and monitor your AL5010's operations.

AL5010 provides ease-of-use regardless of your experience with bar code readers. A beginner follows basic setup procedures for a standard configuration. If you are more experienced, use the advanced setup features that allow access to more complex options.

First-time Setup Procedure

To setup your AL5010 bar code reader:

1. Connect an RJ45 Ethernet cable to the AL5010.
2. Connect the other end of the cable to your laptop/desktop computer.
3. Apply power to AL5010.
4. Set configuration parameters for bar code symbologies, trigger, tracking, and communications (serial, Ethernet, and I/O).
5. Check operations using the Test Mode.

Check Operations using Test Mode



NOTE: Perform the following test using a bar code that matches the default parameters. Or you may wish to perform this test after configuring the AL5010 to your specifications. If the default parameters have been changed, you must enable the control panel buttons and the other parameters listed on page 96. See *Chapter 5, Modify > Configuration and Modify > Bar Code Setup*.

To quickly check the operation of an AL5010:

1. Apply power to the AL5010.
2. Position a test bar code symbol approximately 20 inches (0.5 meter) from the reader. Skew the bar code symbol slightly.
3. Press the Test/Diagnostics button on the control panel to initiate test.
4. The laser(s) should be scanning continuously during normal operations. (Observe the laser safety warnings in Chapter 2. If it becomes necessary to shutoff the laser(s), follow procedure outlined in Chapter 6.)
5. Observe the bar graph LEDs on the AL5010 control panel. The read LED will blink GREEN if it reads a bar code, or RED if it doesn't.
6. Connect your PC via the network.

7. Run the browser-based setup application and establish a connection with the reader.
8. Go to the **Diagnostics > AL5010 Monitor**.
9. During operations, use the **AL5010 Monitor** to confirm the reader's status, read quality, code quality, and messages via the on-screen indicators. (See *Chapter 8, Diagnostics*.)
10. Close the connection to the reader.
11. Disconnect setup cable.

Operations Checklist

- Check trigger photoeye LED for proper operation.
- Test parameters to assure optimal operation.
- Observe the reader's Status Indicator LEDs during power-up. (*What to watch for is outlined on page 95.*)
- Select **Diagnostics > AL5010 Monitor**.
- Pass test label in scanning beam.
- Adjust mounting as needed for optimal performance.
- Modify AL5010 parameters as needed for optimal performance.
- Save parameters to scan head.
- Backup parameters from scan head to mounting base.
- Backup parameters to disk (optional, but recommended).

Control Panel Indicators

There are several control panel indications on the AccuLazr AL5010 Readers and AccuLazr Interface Modules.



The LEDs provide the following indications during normal operations.



Using LED Indicators to Check Normal Operations

LED	Description
STATUS	GREEN to indicate the overall "health" of the reader. (If RED , see <i>Chapter 8, Troubleshooting</i> .)
TRIGGER	Indicates the trigger input. The LED is activated upon trigger input regardless of trigger source (incl. software trigger).
READ	Flashes red or green based upon the software criteria.
RX/TX	LED for serial port 1. GREEN = Transmitting data RED = Receiving data
NETWORK	Flashes red or green to indicate connection status. <ul style="list-style-type: none"> ▪ For a Single TCP/IP connection, it indicates that a "host" connection has been made to the reader. ▪ For EtherNet/IP connection, it indicates "network" connection status. This LED is software controlled. ▪ For a Controller/Client multi-reader connection, it indicates that all inter-reader communications (connections between readers) are correctly functioning.
LINK	This LED is LINK indicator for Ethernet. Flashes GREEN when connected to a network.
Bar Graph (LED 1 - 5)	<ul style="list-style-type: none"> ▪ Scan quality indicator. ▪ Flashes when parameters copied to/from mounting base. ▪ LEDs stay on when Test/Diagnostic button C is pressed during the laser shutoff procedure.

NETWORK LED during Normal Operations

Mode	Description
Single TCP/IP	Solid GREEN – AL5010 connected to a host. NOTE: If both Host 1 and Host 2 are used, the LED will be solid GREEN if either port is connected. Off – No host connection. NOTE: If UDP messaging is used (unconnected messages) the Network LED will be off.
EtherNet/IP	Solid GREEN – AL5010 made a connection to the PLC Flashing GREEN – No connection made with the network Flashing RED – Lost network connection
Controller/Client	<p>Controller</p> <p>Solid GREEN – The correct number of client(s) with the same group number have been found. Flashing RED – All the client(s) with the same group number have NOT been found</p> <p>Client</p> <p>Solid GREEN – Connected to a controller with the same group number. Off – Not connected to a controller with the same group number.</p>
<p>NOTE: The mode indicated by the Network LED is dependent on the AL5010 configuration you are using. Ethernet/IP is the highest priority, Single TCP/IP mode operation is the lowest.</p>	

Using Control Panel Buttons to Check Normal Operations

Ref	Button	Description
	Restore to Scan Head	Restores parameters from Mounting base to Scan Head <ul style="list-style-type: none"> ▪ Button must be pressed twice to initiate action. ▪ See page 99 for procedure.
	Backup to Mounting Base	Downloads parameters from Scan Head to Mounting base <ul style="list-style-type: none"> ▪ Button must be pressed twice to initiate action. ▪ See page 99 for procedure.
	Test /Diagnostic (Laser Shutoff)	<ul style="list-style-type: none"> ▪ Enables the AL5010 test mode. (Test mode can also be selected remotely using <i>Tools > Commands > Test Mode.</i>) ▪ Use to perform laser shutoff. (See page 107.)



REMEMBER: AL5010's control panel buttons can be enabled / disabled through the use of the browser-based setup application. (See *Modify > AL5010 Configuration, Enable AL5010 Control Panel Buttons.*)

Interface Module Status Indicators

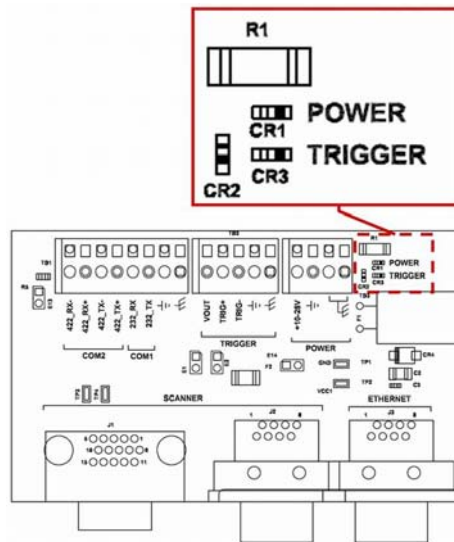

LEDs on Basic Interface Module

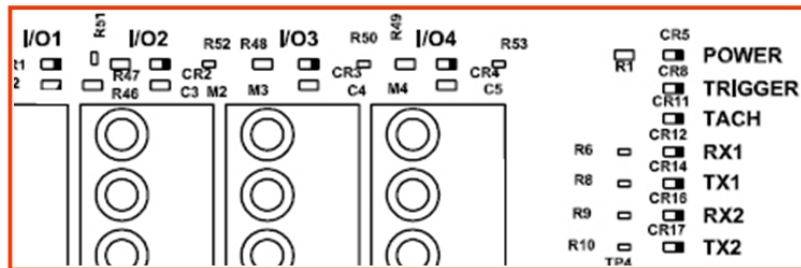

LEDs on Enhanced Interface Modules

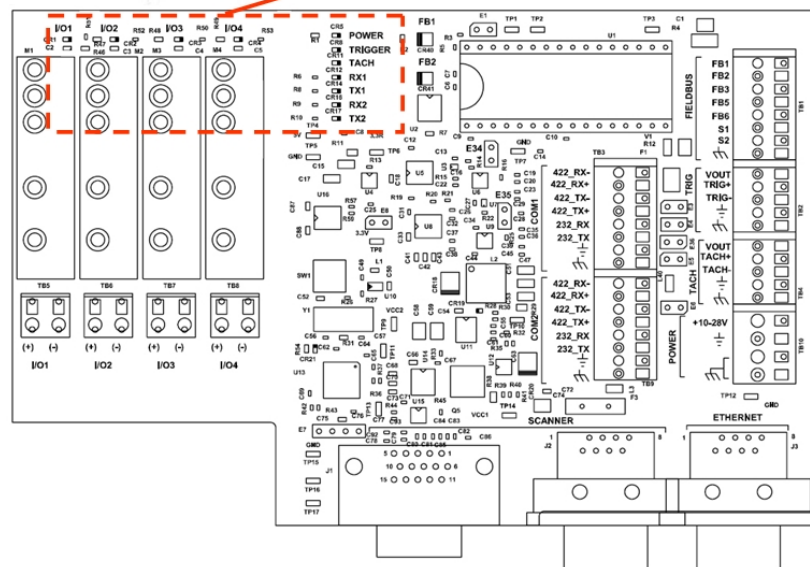

FieldBus LED Status Indicators**DEVICENET**

Module Status	Off - No power
FB1	Green Normal operation
FB1	Green, flashing Auto Baud in progress
FB2	Red Unrecoverable Fault(s) detected
FB2	Red, flashing Recoverable Fault(s) detected
	Alternating Red/Green Self test in progress
Network Status	Off - Not online - or - no power
FB3	Green On-line, one or more connections established
FB3	Green, flashing On-line, no connections established
FB4	Red Critical link failure
FB4	Red, flashing Connection timeout
	Alternating Red/Green Self test in progress

PROFIBUS

LED	State	Color	Description
FB1	Clear (0)	Off	Node Off-Line or Power not supplied
	Set (1)	Green	Node in Data Exchange Mode
	Toggling (1Hz)	Green, flashing	Node in Clear Mode
FB2	Clear (0)	Off	No Error or Power not supplied
	Set (1)	Red	Error in initialization of PROFIBUS
ASIC	Toggling (1Hz)	Red, flashing	Error in configuration data and/or User Parameterization Data

Backup / Restore Procedures

To backup parameters from scan head to mounting base:

1. Press the **backup** button for about 1 second.
2. Release button. The bar graph LEDs continuously flash to indicate the button has been pressed long enough. If the LEDs flash only once, the button was not pressed long enough.
3. Press button a second time while LEDs are flashing. Hold for about 1 second.
4. Release button. The bar graph LEDs strobe from 5 to 1 indicating parameters are being backed up from scan head to mounting base.
5. When the LEDs stop strobing, the backup is complete.

To restore parameters from mounting base to scan head:



NOTE: The restore parameters function can cause the scanner to reboot.

1. Press the **restore** button for about 1 second.
2. Release button. The bar graph LEDs continuously flash to indicate the button has been pressed long enough. If the LEDs flash only once, the button was not pressed long enough.
3. Press button a second time while LEDs are flashing. Hold for about 1 second.
4. Release button. The bar graph LEDs strobe from 1 to 5 indicating parameters are being uploaded from mounting base to scan head.
5. When the LEDs stop strobing, the upload is complete.

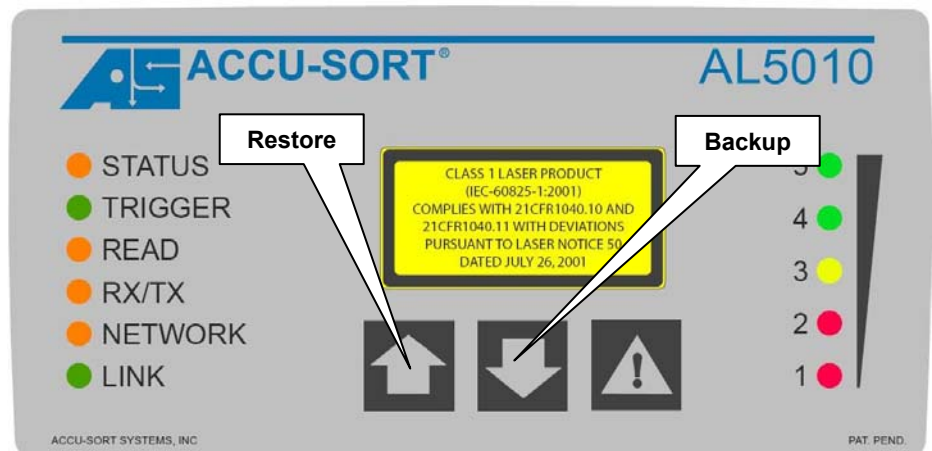

Button and LEDs involved with Backup / Restore

Checking Operations with User Interface

The **Diagnostics > Monitor** enables you to evaluate the operational performance of your AL5010 by providing vital statistics via status indicators, real-time read quality monitoring, and box information. Outgoing and incoming messages are also monitored.

Status LEDs

<input checked="" type="checkbox"/> Status	<input checked="" type="checkbox"/> Network
<input checked="" type="checkbox"/> Trigger	<input checked="" type="checkbox"/> I/O 1
<input checked="" type="checkbox"/> Good/No Read	<input checked="" type="checkbox"/> I/O 2
<input checked="" type="checkbox"/> Multiple codes	<input checked="" type="checkbox"/> I/O 3
<input checked="" type="checkbox"/> Match	<input checked="" type="checkbox"/> I/O 4

Read Quality

Read Rate: ██████████ ██████████ 73

Scans/Code: 26

Code Quality (CQ): 73

Code Position: 2619

Laser 1: 0

Laser 2: 10

Messages

```

3037477262 QQ:10 (0/10)
3037477262 QQ:10 (0/10)
3037477262 QQ:10 (0/10)
<NOREAD>
3037477262 QQ:10 (0/10)
3037477262 QQ:10 (0/10)
3037477262 QQ:10 (0/10)
<NOREAD>
3037477262 QQ:10 (0/10)

```

Box Information

Belt Speed (fpm): n/a

Belt Length (in.): n/a

Code Position (in.): n/a

Scans/Trigger: 0

Message Monitor

```

\023037477262\0D\0A
\02?????????\0D\0A
\023037477262\0D\0A
\023037477262\0D\0A
\023037477262\0D\0A
\023037477262\0D\0A
\02?????????\0D\0A
\023037477262\0D\0A

```

None Serial Port 1 Serial Port 2 Net Port 1 Net Port 2

Diagnostics > Monitor Window

Checking Multi-Reader Network

From the AL5010 Controller, check **Diagnostics > Log Viewer > Read Rate**. This simple diagnostic allows you to check bar codes read, by laser, for each AL5010 Client in the network. Each client is identified in the Read Rate Log by the unique name and IP address assigned to it.

See *Chapter 5* and online help for more information.

Standalone Operation

In a typical standalone setup, a single AL5010 scans bar codes on one side of packages as they move down a conveyor. A photoeye is used to trigger the AL5010 to begin searching for valid bar codes. Bar code data is transmitted to a host device.

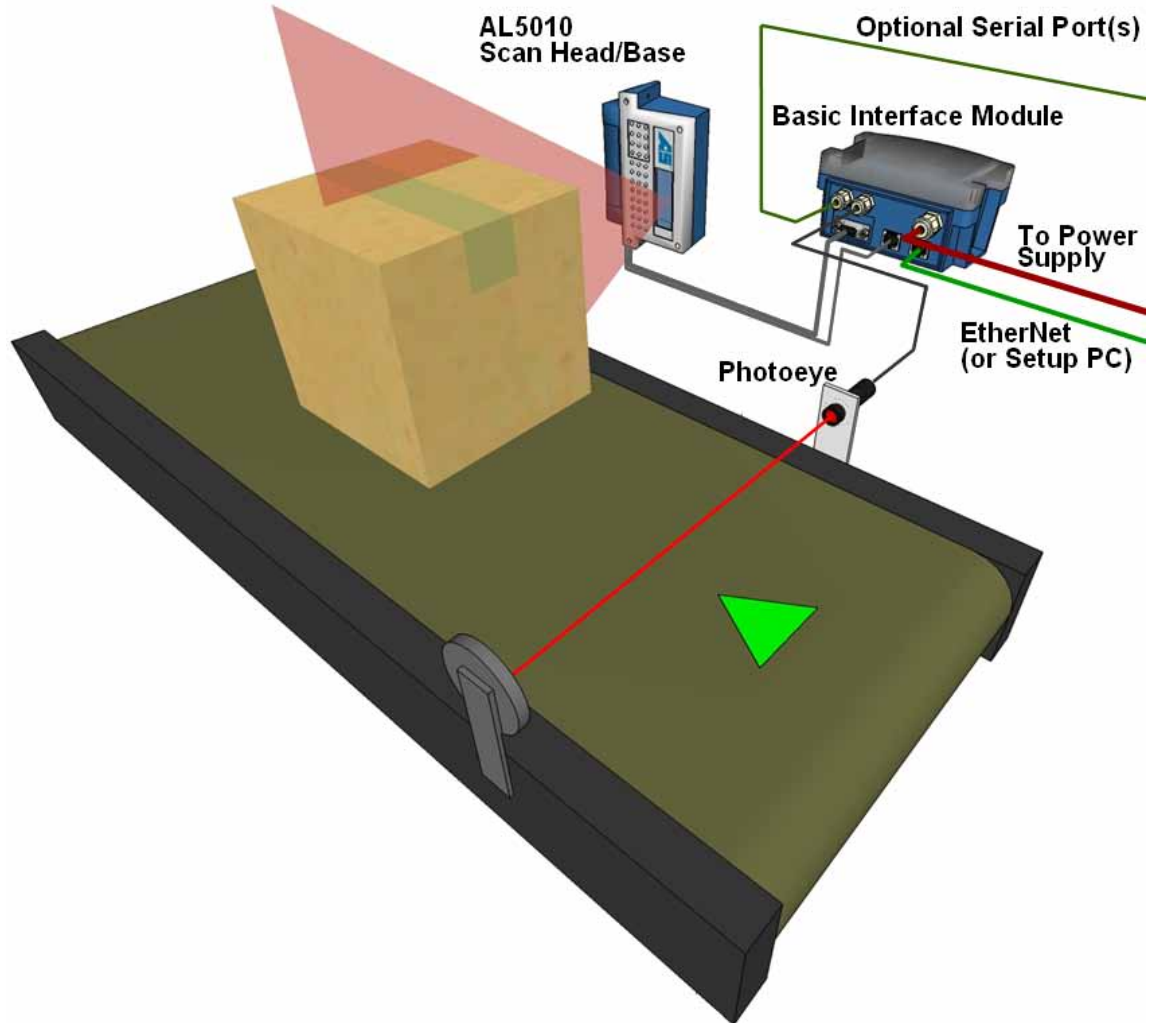

Typical Single-Unit AL5010 Applications

Tracking Operation

By utilizing the tracking capabilities of the AL5010, you can configure your application to monitor the progress of packages on the conveyance system. Tracking enables the AL5010 to track bar codes and the packages to which they belong. Your reader may scan more than one package with more than one code at a time within its read zone. Tracking allows the reader to accurately associate the correct bar code(s) with the correct packages.

Typical tracking configurations use a tachometer to monitor conveyor speed. A simplified diagram of the required items for a tracking application is shown below:

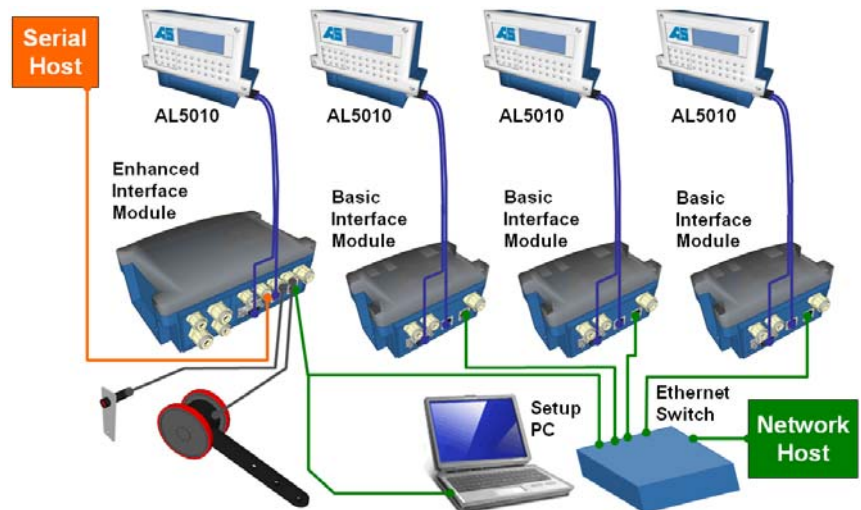

Setup Functions for AL5010 Tracking Operation

- Modify > Tracking – Tachometer (define tach type)
- Modify > Tracking – AL5010 Mounting
- Modify > Tracking – Transmit
- Modify > Tracking – Track Config

Basic Tracking Setup Procedure

To assure tracking accuracy, the distance from the Trigger Photoeye to the “X” scanning pattern must be measured and entered in the user interface.

1. To properly track-in the AL5010, drop a plumb bob from the center of the AS logo on the scan head.
2. Measure the distance (in inches) from the plumb bob to Trigger Photoeye.
3. Establish a connection with the AL5010.
4. Enter the value (in inches) into the **Modify > Tracking > AL5010 Mounting > Trigger Reference Point** field.



IMPORTANT: After completing the basic tracking setup, see the advanced tracking procedure provided in the **Modify > Tracking** section. The **Tracking > Trigger Reference Point, Closest Read Point** and **Furthest Read Point** parameters must be properly set. (See Chapter 5.)

Dual X-Scanning Operation

In dual X-scanning applications, four AL5010 readers mounted side-by-side are used to create a dual “X” scanning patterns across the entire width of a conveyor. Four UMB brackets and four AL5010 readers can be used to create a dual-X scanning pattern.

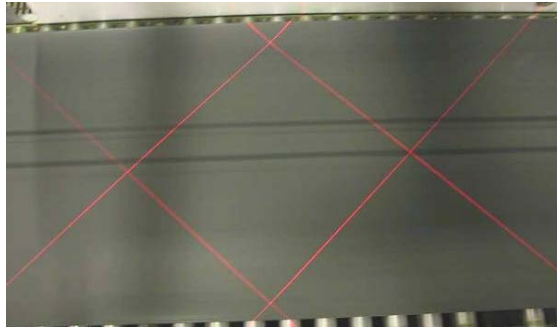

Dual X-pattern can be created by four AL5010 readers

Dual X-Scanning Application

A simple illustration of the required items for a double X-scanning configuration is shown below:

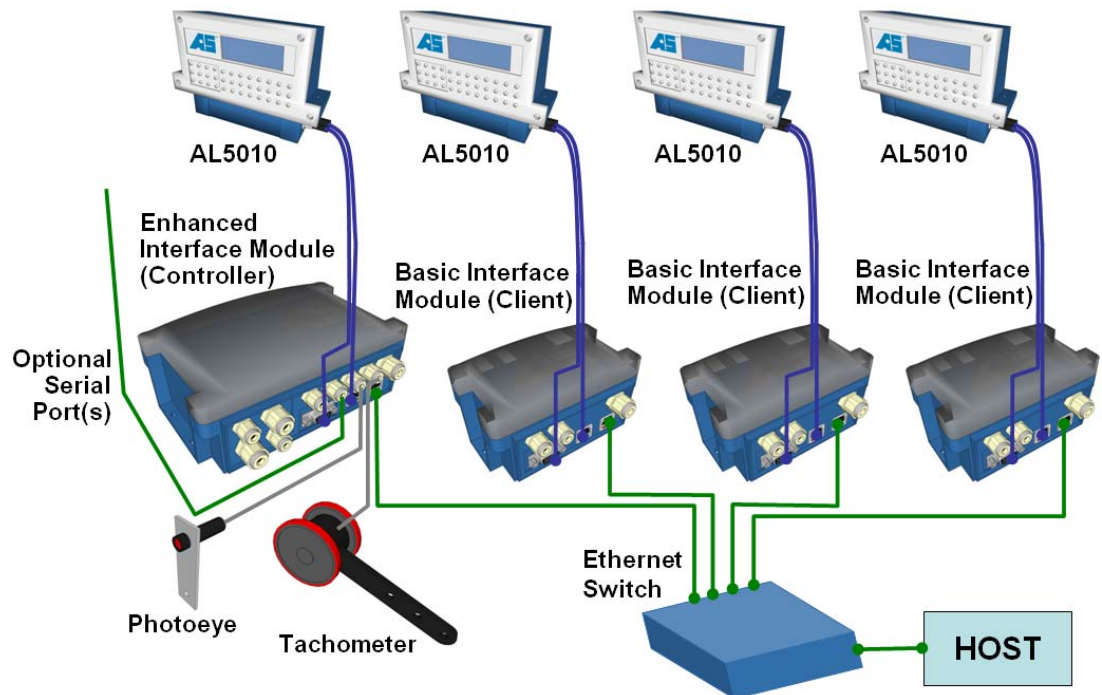

Setup Functions for AL5010 Controller

- Modify > AL5010 Configuration - Reader Name (Controller)
- Network Settings - # of Client Readers, IP address, and Group #

Setup Functions for AL5010 Clients

- Modify > AL5010 Configuration - Reader Name (Client 1,2,3)
- Network Settings – IP address and Group #

See Chapter 5 and online help for details on setting up a multi-reader network.

Multiple-Reader Network Operation

In multiple-reader applications, from 2 to 14 AL5010s can be networked together. A single AL5010 is configured as a *Controller* for a multiple-reader network. The AL5010 Controller gathers data from other AL5010s (up to 13, configured as *clients*) over an Ethernet network. The AL5010 Controller then collects and transfers the collected data over a serial communications or network link to the host.

A simplified schematic diagram of the required items for a multiple-reader configuration is shown below:

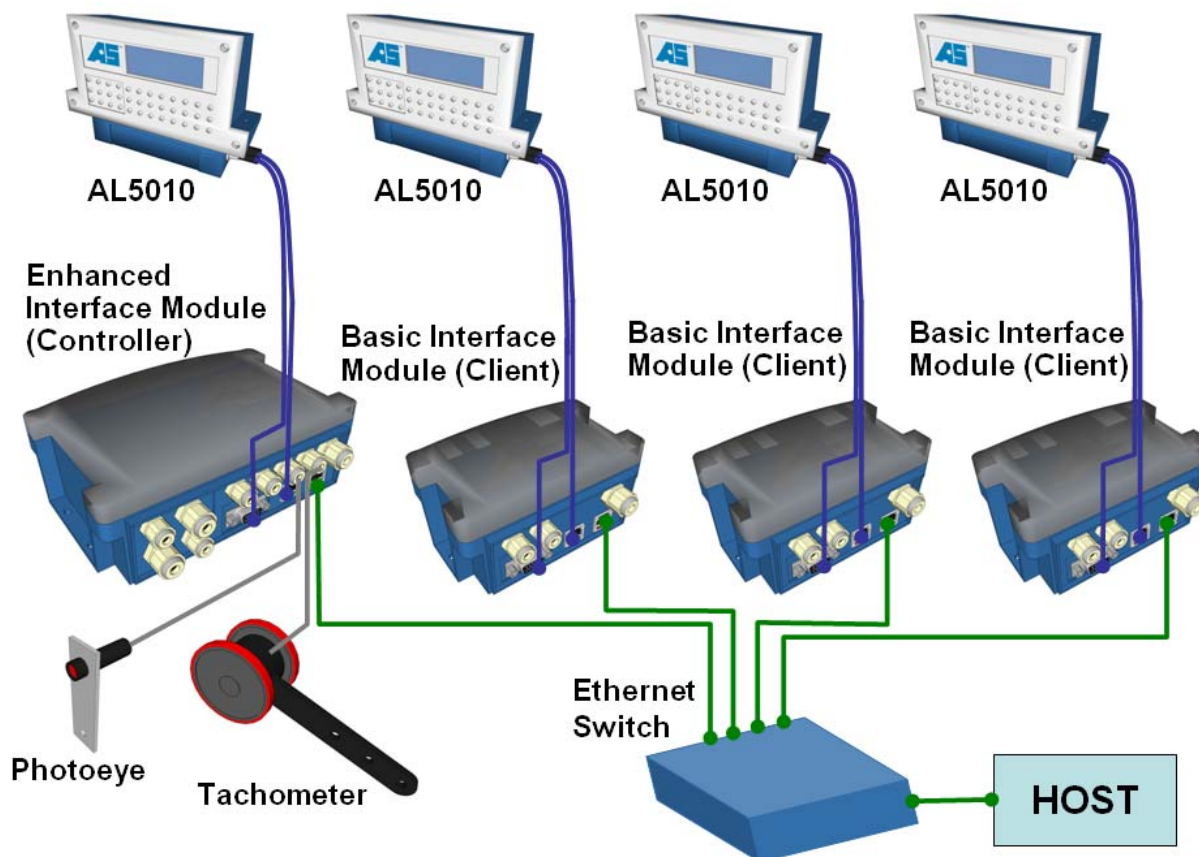

Setup Functions for AL5010 Controller

- Modify > AL5010 Configuration - Reader Name (Controller)
- Network Settings - # of Client Readers, IP address, and Group #

Setup Functions for AL5010 Clients

- Modify > AL5010 Configuration - Reader Name (Client 1,2,3)
- Network Settings – IP address and Group #

See Chapter 5 and the online help for details on setting up a multi-reader network.

Scanning Array / Tunnel Operations

The AL5010 can be set up with 1 controller and up to 13 clients in a single system and functioning in the same scanning area, the entire application is called a scanning array or tunnel.



NOTICE: Due to the complexity of these applications, tunnel arrays are typically custom-engineered to your specifications.

Setup Functions for AL5010 Controller

- Modify > AL5010 Configuration - Reader Name (Controller)
- Network Settings - # of Client Readers, IP address, and Group #

Setup Functions for AL5010 Clients

- Modify > AL5010 Configuration - Reader Name (Client 1,2,3,4,5)
- Network Settings – IP address and Group #

See Chapter 5 and the online help for details

7 Maintenance

This chapter provides instructions for maintaining optimum performance and life for your AL5010. It provides specific information on:

- Maintenance Procedures
- Exterior Cleaning
- Mounting Hardware Checks
- Wiring Connection Checks

Tools and Materials Required

Item	Description
Soft-bristle brush	For cleaning the reader's exterior
Clean soft cloths	For cleaning the reader's exterior
Cleaning solutions	Mild detergent solution for cleaning the reader's exterior. 70% denatured alcohol, 30% de-ionized water solution for cleaning exit window
Soft cotton swabs or lint-free cloth	Use to clean reader's exit window

Laser Shutoff Procedure

In order to perform certain maintenance and service tasks, the reader's lasers must be shut off in order to comply with all laser safety requirements.

To shutoff the lasers:

1. Press the **Test/Diagnostics** button (!) for 5 seconds.
2. The bar graph LEDs will light for the 5 second duration and then go out.
3. The lasers will then shut off.
4. After maintenance or service is complete, repeat the process to turn the lasers back on.



AL5010 Button and LEDs involved with Laser Shutoff

Maintenance Tasks

Perform the maintenance tasks on an “as needed” basis to assure proper operation of the AL5010. Task schedule frequency depends upon the application environment conditions. It only requires a few minutes to complete each maintenance task.

Exterior Cleaning



WARNING: Shut down the reader before performing this maintenance task. Do not stare into the reader’s exit window at the laser light. Avoid direct eye exposure. The laser light level does not constitute a health hazard, however staring at the laser light for prolonged periods could result in eye damage.



WARNING: *There are no user serviceable parts inside the AL5010.* No internal components of the AL5010 are field replaceable units (FRUs). Opening the unit will potentially expose the user to emitted laser radiation, high voltage, and could reduce the effectiveness of the device’s IP rating. **DO NOT REMOVE** the faceplate from the scan head enclosure. Opening the AL5010 will also void the factory warranty.



CAUTION: CLASS 3R LASER RADIATION. WHEN OPEN AVOID DIRECT EYE EXPOSURE. *See warning above.*



CAUTION: Do not use any chemical on the reader that is unsafe for plastics, such as benzene, acetone, or similar products. Before performing this maintenance task, be sure to shutdown the reader.

The exterior cleaning procedure may be performed without removing the reader from the mounting structure.

1. Turn off the reader’s lasers.
2. Clean the exterior (except the exit window) with a clean, soft-bristle brush. Be sure not to brush any dust, dirt, or debris onto the exit window.
3. Carefully remove any debris in or around the exit window.
4. Wipe the exterior (except the exit window) with a clean, soft cloth dampened slightly with a mild detergent solution.
5. The exit window should be cleaned after this task is completed.

Cleaning the Exit Window



WARNING: Shut down the reader before performing this maintenance task. Do not stare into the reader's exit window at the laser light. Avoid direct eye exposure. The laser light level does not constitute a health hazard, however staring at the laser light for prolonged periods could result in eye damage.



WARNING: *There are no user serviceable parts inside the AL5010.* No internal components of the AL5010 are field replaceable units (FRUs). Opening the unit will potentially expose the user to emitted Class 3 laser radiation, high voltage, and could reduce the effectiveness of the device's IP rating. **DO NOT REMOVE** the faceplate from the scan head enclosure. Opening the AL5010 will also void the factory warranty.



CAUTION: CLASS 3R LASER RADIATION. WHEN OPEN AVOID DIRECT EYE EXPOSURE. *See warning above.*



CAUTION: Never apply cleaning solution directly to the exit window. Always apply the solution to a cloth, and then the cloth to the window. Do not use any chemical on the reader that is unsafe for plastics, such as benzene, acetone, or similar products.

The exit window cleaning procedure may be performed without removing the reader from the mounting structure if it is possible to do so.

1. Turn off the reader's lasers.
2. Follow the exterior cleaning procedure before cleaning the exit window.
3. Check the exit window surface for any dust, dirt, or smudges. If the window needs to be cleaned, proceed to Step 4.
4. Make a solution of seven parts denatured alcohol and three parts water.
5. Apply the cleaning solution to a cotton swab or lint-free cloth.
6. Apply the cleaning solution to the exit window.
7. Remove any streaks or remaining moisture from the exit window with a dry, soft, lint-free cloth or lens paper.
8. Turn the reader's lasers back on.
9. Verify reader operation. Follow the Operations Checklist procedure in Chapter 5.



Cleaning the Trigger Photoeye

If your application uses the photoeye option as a hardware trigger, be sure to clean the photoeye periodically as outlined below.

1. Turn off the product transport.
2. Turn off the reader's lasers.
3. Clean the photoeye's lens using the denatured alcohol solution and a cotton swab or lens paper. Check the reflector on the opposite side of the transport.
Clean as necessary.
4. Verify photoeye operation.



Cleaning the Tachometer

If your application uses the tachometer option for tracking purposes, be sure to clean the tachometer wheels periodically as outlined below.

1. Turn off the product transport.
2. Turn off the reader's lasers.
3. Using a clean, soft cloth, wipe the wheels of the tachometer clean using a mild detergent solution.
4. Before restarting the system, be sure the tachometer is making good contact with the product transport.
5. Verify tachometer operation.

Tighten Mounting Hardware

1. Check all reader mounting hardware.
Tighten as necessary. Do not over-tighten.
Be sure not to disturb the reader's alignment as it relates to the product transport.
2. Check the mounting hardware of the photoeye and tachometer (if these options are being used). Tighten as necessary. Do not over-tighten.

Checking Interface Module Connections

All wiring connections are typically made to an interface module.
(See *Chapter 3, Installation.*)

1. Check all cord grips.
Tighten as necessary. Do not over-tighten.
2. If a cord seems loose, also check the wiring connections to the terminal blocks. Tighten as necessary. Do not over-tighten.
3. Check all cabling/conduit for signs of wear/damage.
Repair/replace any damaged cable connections as necessary.

Verify Reader Operation

Follow the Operations Checklist procedure defined in Chapter 5.

If the reader parameters were changed to read bar codes other than the factory defaults, simply use a good quality bar code to assist in verifying proper operations. There is no need to return the reader to the default parameters to perform this test.

Verify Photoeye Operation

1. Block the photoeye beam to confirm it is aligned properly with the reflector.
2. If the LED on the photoeye changes status, the photoeye is functioning properly.



Trigger Photoeye – Status LED Location

3. Verify that the Trigger LED on reader is green when photoeye beam is blocked.
4. If the photoeye's LED does not change status, adjust the photoeye so that it is properly aligned with the reflector.
5. If the Trigger LED on the reader is not green when the photoeye's beam is blocked, check the cabling between the photoeye and reader mounting base for damage.

Verify Tachometer Operation

There are two ways to verify tachometer operations.

Use AccuLazr User Interface

1. Establish a connection with the reader.
2. Go to **Diagnostics > Monitor**.
3. Verify the **Belt Speed** is accurate when the conveyor is running.

Use Tach LED in Enhanced Interface Module

1. Locate the Tach LED.
2. Slowly spin the tachometer wheel.
3. Verifying the tach LED in the mounting base is flashing.

8 Troubleshooting

This chapter provides instructions for diagnosing, troubleshooting and correcting AccuLazr AL5010 performance issues. It provides specific information on:

- Test Mode
- Indicators
- Diagnostics
- Troubleshooting (Problem/Cause/Solution)

Test Mode

In test mode, the AL5010 displays the read rate on the AL5010 control panel's bar graph LEDs. The **Diagnostics > Monitor** window also provides a read quality bar graph that enables you to monitor the test mode remotely from a PC connected to your network. Additional details can be obtained by monitoring from this diagnostic window while the reader is in test mode.



NOTE: Test mode will continue running until you click **Stop Test Mode** on the Monitor screen or press the  button on the back of the reader.

Status Indicators

The AccuLazr AL5010 provides several status indicators that you can use to troubleshooting performance during operations. They are found at two locations:

- Control Panel
- **Diagnostics > Monitor** screen

Control Panel Indicators

There are several control panel indications on the AccuLazr AL5010 Readers and AL5010 Interface Module.



AL5010 Reader Control Panel

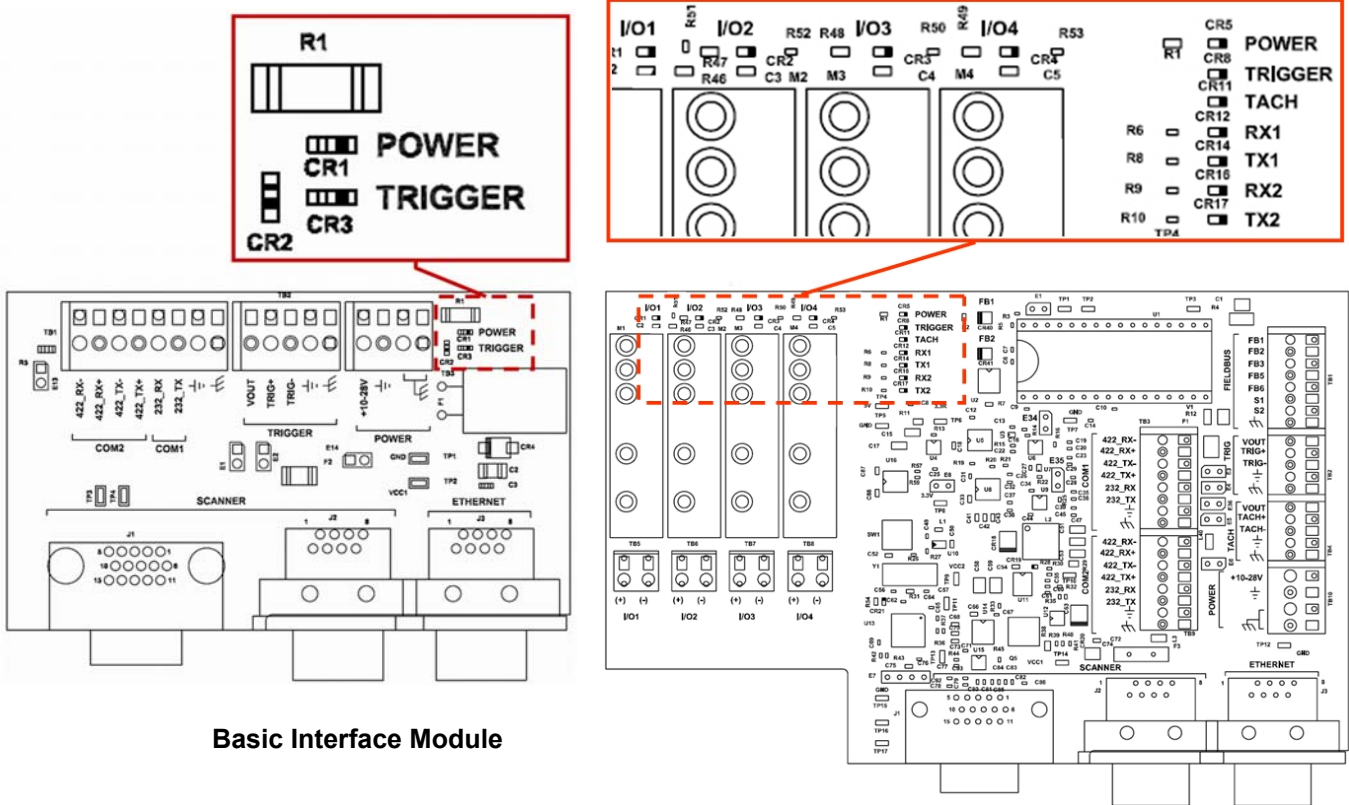

Basic Interface Module

Enhanced Interface Module

AL5010 Interface Module Status Indicator LEDs

Control Panel LED Fault Detect Descriptions

LED	Description
STATUS	RED indicates a problem regarding the overall "health" of the reader.
TRIGGER	Indicates the trigger input. The LED is controlled through software no matter the trigger source (including software trigger).
READ	RED identifies a No Read condition. Check bar code print quality, trigger configuration, and bar code parameters.
RX/TX	If bar codes are being read, but the LED is NOT illuminated, data is not being transmitted on serial port 1.
NETWORK	<i>(See Network LED – Fault Detection.)</i>
LINK	If the LED is not flashing, there is no network connection.
Bar Graph (LED 1 – 5)	Read quality indicator (5 = Good, 1 = Poor). 5 = 81-100% 4 = 61-80% 3 = 41-60% 2 = 21-40% 1 = 00-20% NOTES: Also flashes during parameter upload/backup.
(Laser Shutoff)	LEDs stay on when Test/Diagnostic button C is pressed during the laser shutoff procedure.



NETWORK LED – Fault Detection Only

Mode	Description
Single TCP/IP	LED is Off – No host connection or UDP messaging is used. NOTE: If UDP messaging is used (unconnected messages) the Network LED will be off.
EtherNet/IP	Flashing GREEN – No connection made with the network Flashing RED – Lost network connection
Controller/Client	Controller Flashing RED – All the client(s) with the same group number have NOT been found or a client's tracking does not match the controller. Client Off – Not connected to a controller with the same group number. Match the client to the controller's group number. Solid RED – Client's tracking does not match the controller.

NOTE: The mode indicated by the Network LED is dependent on the AL5010 configuration you are using. Ethernet/IP is the highest priority, Single TCP/IP mode operation is the lowest.

NOTE: See *Network LED during Normal Operations*.

Control Panel Buttons – Uses during Troubleshooting

Ref.	Button	Description
	Restore to Scan Head	Use to restore a set of parameters from the wiring base to a replacement scan head. NOTE: This only works if the Backup to Base button has been used earlier to assure the correct parameters are stored in the wiring base.
	Backup to Base	When it becomes necessary to replace a scan head, be sure to use this button to download a backup set of parameters from the scan head to the wiring base. By doing this, it is easy to configure your replacement scan head by using the Upload to AL5010 button.
	Test /Diagnostic (Laser Shutoff)	Enables the AL5010 test mode. (Test mode can also be selected remotely using <i>Tools > Commands > Test Mode On.</i>) Use to perform laser shutoff.



NOTE: Keep in mind that the buttons on the reader's control panel can be enabled/disabled through the use of the AccuLazr user interface.
(For details, see Chapter 5.)

Diagnostics

The **AccuLazr User Interface** includes comprehensive diagnostic capabilities that monitor reader operation, triggering, conveyor speed, package and label dimensions, bar code readability, scan rates and message output.

The **Diagnostics > Monitor** window is the primary tool used to monitor the reader's operation and bar code readability in real-time.

The **Diagnostics > Log Viewer** lets you review the performance logs saved by the AL5010. The log view field remains empty until you select one of the three buttons (Read Rate, System Counters, or Message Log).

Update Firmware is used to reload the reader firmware.

Monitor

Status indicators and vital statistics appear on a single screen, enabling you to effectively and efficiently detect and troubleshoot any problems that may occur in high-speed laser bar code scanning.



Diagnostics > Monitor (Active)

Status LEDs

The Monitor status indicators reflect the AL5010 control panel LEDs functionality as well as additional LEDs such as the Match and I/O LEDs.

Status LED Definitions

LED	Definition of Conditions
Conditions	
Status	
Green	Indicates the overall "health" of the reader.
Red	Fault condition: Troubleshooting is required.
Trigger	
Green	Indicates the trigger input. The LED is activated upon trigger input regardless of trigger source (including software trigger).
Good/No read	
Green	Indicates a good (valid) bar code has been decoded.
Red	Indicates a no-read (or incomplete decode).
Multiple codes	
Red	Indicates more codes than desired were read.
Match	
Green	Indicates a code matches the Match Code criteria.
Network	
Flashes green or red to indicate connection status. Example: A red Network LED upon power up could indicate the MAC address was not set at the factory).	
<ul style="list-style-type: none"> ▪ For a Single TCP/IP connection, it indicates that a "host" connection has been made to the reader. ▪ For EtherNet/IP connection, it indicates "network" connection status. This LED is software controlled. ▪ For Controller/Client multi-reader connections, it indicates all inter-reader communications (i.e., connections between readers) are correctly functioning. 	
I/O #1 through I/O #4	
Green	Indicates the status of the programmable I/O lines.

Network LED during Normal Operations

Mode	Description
Single TCP/IP	Solid green – AL5010 connected to a host. NOTE: If both Host 1 and Host 2 are used, the LED will be solid green if either port is connected. Off – No host connection. NOTE: If UDP messaging is used (unconnected messages) the Network LED will be off.
EtherNet/IP	Solid green – AL5010 made a connection to the PLC Flashing green – No connection made with the network Flashing red – Lost network connection
Controller/Client	Controller Solid green – The correct number of client(s) with the same group number have been found. Flashes red – All client(s) with the same group number have NOT been found Client Solid green – Connected to controller with same group number. Off – Not connected to controller with same group number.
NOTE: The mode indicated by the Network LED is dependent on the AL5010 configuration you are using. Ethernet/IP is the highest priority, Single TCP/IP mode operation is the lowest.	

Read Quality

The Read Quality indicators provide information regarding the bar code that was read.

Read Quality Definitions

Read Quality	Definition
Graph 0-100	The large percentage bar maps to the values displayed on the reader bargraph. It is a measure of “how well” the bar code was read.
Scans/Code	Indicates how many passes of the laser (scan lines) contributed to the reading of the code.
Code Position (slider)	Indicates the bar code’s position in the AL5010’s scan line (from zero to 4095).
Code Quality (QQ) Laser 1 through 4	Indicates the QQ (code quality) value for each laser that read the bar code.

Box Information

The availability of diagnostic information within these fields depends on whether tracking is enabled or not. The first three are only available in tracking and the last one only in triggered, non-tracking modes. These items are only updated when a trigger occurs. To monitor belt speed more accurately, it can also be viewed as part of the System Counters in the log viewer.

Box Information Definitions

Box Information	Definition
Belt Speed (FPM)	Belt/conveyance speed in feet per minute
Box Length (inch)	Box/package length in inches
Code Position (inch)	Bar code position on the box in inches
Scans/Trigger	Number of scans per trigger cycle

Messages

Diagnostic messages from the reader are displayed here. This is primarily information on each bar code read.

Message Monitor

The message monitor can be used to monitor the messages being sent from any of the reader host ports (either serial or network). As with messages, options for clearing, starting, stopping and logging this information are made available by **right clicking**.

Message Monitor Definitions

Message Monitor	Definition
(Display Field)	Displays the message transmitted
None	Select the port to be monitored.
Com Port #1	The AL5010 will not attempt to send messages out Net Host ports unless a connection is already established.
Com Port #2	
Net Host #1	Note: Nothing is displayed on Net Host #1 if EtherNet/IP communications are being used.
Net Host #2	

Log Viewer

The **Diagnostics > Log Viewer** lets you review the performance logs saved by the AL5010. The log view field remains empty until you select one of the three most common logs (Read Rate, System Counters, or Message Log) via the buttons or enter a log request in the Command field.

Log Viewer Commands

There are several commands that you can use to display AL5010 parameters and diagnostic information. Commands can be sent from the Command field on the log viewer. Commands may also be sent from a terminal interface, such as a TELNET connection to the AL5010.

Log Viewer Command Descriptions

Display Commands	Description
DISP COUNTERS	Display the System Counter log view.
DISP ENET	Display the Ethernet interface status including MAC address.
DISP LASERS	Display ALL Lasers log view.
DISP LASERx	Display one Laser log view, where X is 1 – 2.
DISP MSGLOG	Display the Message log view.
DISP READRATE	Display the Read Rate log view.
Other Commands	Description
CLEAR ALL	Clears all information from the Message Monitor.



NOTE: All commands can be issued from the Command field. However, when entering a command in the field, spaces are NOT permitted. As a result, the display commands need to be entered without a space (i.e., DISPCOUNTERS, DISPMSGLOG, etc.)



NOTE: Right-click on log view provides two options: **Save LogView to File** (also available from Tools) and **Copy to Clipboard**.

Read Rate Log View

For a summary of the AL5010's overall performance, click the **Read Rate** button. You can also enter **DISPREADRATE** in the command field and click **Send**.

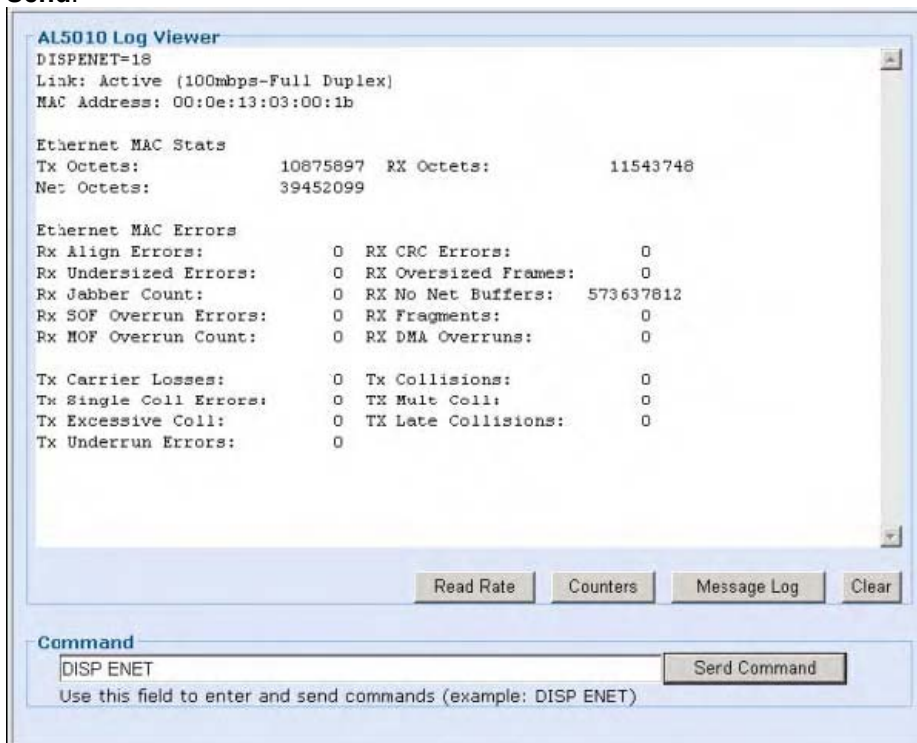

Diagnostics > Log Viewer (Read Rate selected)

The Read Rate Log Viewer provides information on the overall read rate.

Overall Read Rate Counters

Read Rate	Description
Total Boxes	Total number of triggers.
Good Boxes	A good box is a box with all required codes. This counter is the number of good boxes along with the percentage of the total boxes that were good.
Partial Boxes	A partial box is a box where some, but not all required codes were read. This obviously only applies when the AL5010 is configured to read multiple codes each trigger.
Bad Boxes	A bad box is a box where no codes were read.

The Read Rate Log Viewer also provides performance information on each laser. In order to provide diagnostics on the performance of each laser, the percentages reference here are the percentage of the **total codes** read by the particular laser, NOT the percentage of the **total packages** read by that laser.

Read Rate Counters per Laser

Read Rate	Description
Total Codes	Total number of bar codes read.
Laser#x	Total number of bar codes read by the particular laser.

For an AL5010 configured as a Controller in a multi-reader network, this command also provides counters for the number of bar codes read, by laser, for each AL5010 client. The clients are identified by their *reader name* as assigned in *Modify > Configuration*. (See Chapter 5.)



REMEMBER: Not every AL5010 is configured with two lasers.

System Counters Log View

You can display a number of values and counters that indicate whether the AL5010 is configured and operating properly by clicking the System Counters button. You can also enter **DISPCOUNTERS** in the command field and click **Send**.

Scan Rate and Belt Speed System Counters

	Description
Scan Rate	This is the total number of scans/second that the AL5010 is reading. Note the this number does NOT take into account "laser toggling" if it is enabled. If "laser toggling" is enabled, the effective scan rate for any laser is half of this value.
Belt Speed	(tracking) Speed of the belt (in ft/min) as measured by the tachometer.

Bar Code Counters

Bar Code Counters	Description
Triggers	Total number of packages based on the trigger signal. In self-trigger mode, this will match the number of good reads.
Good Reads	Total number of bar codes read and transmitted. If the AL5010 is set up to read multiple bar codes each trigger, this counter is incremented for each bar code read.
No Reads	Total number of bar codes that were not read.
Mult Codes	Total number of instances where more bar codes of a specific type were read than expected. This counter will also increment, regardless of whether the AL5010 is configured to report "multiple codes" as an error.
Match Codes	Total number of bar codes that matched any of the Match Code criteria.
Bad ModChk	Total number of bar codes that were rejected due to an invalid Mod Check.

Error Counters

Error Counters	Description
Xfter Ovrflw	Transfer Overflow. This counts the number of codes that were lost due to an overflow in the transfer buffer between the Decode/DSP processor and the AL5010/ARM processor.
Xfer BadLen	Transfer Bad Length. Number of codes in the transfer buffer than contained an invalid length, indicating some sort of memory corruption.
QData@TX	Queue Data at Transmit (non-tracking). This counter indicates that the AL5010 had not completed processing all of the scan data at the user specified transmit time. This will only happen if the "transmit time" parameter is set to a value other than zero. This does not necessarily indicate an error, but does indicate that either the transmit time is too short or the AL5010 is seeing a lot of data which may be the result of too much background noise.
QData@Trig	Queue Data at Trigger (non-tracking). This counter indicates that the AL5010 had not completed processing all of the scan data prior to the start of the next trigger. This typically can only happen when the "transmit time" parameter is set to zero; although it can also happen in conjunction with a Force Transmit. As with the Queue Data at Transmit counter, this does not necessarily indicate an error, but it likely indicates that the AL5010 is seeing a lot of data which may be the result of too much background noise.

ForcedTx	Forced Transmit (non-tracking). A forced transmit indicates that the start of trigger occurred before the specified transmit delay time had expired.
Lost Codes	Lost Codes (tracking). If a bar code cannot be placed onto any package while in tracking, the code is "lost" and this counter is incremented. Lost codes are also reported in the AL5010 Monitor message window. Lost code occurrences typically indicate tracking parameters need to be adjusted.
Missed Tx	Missed Transmit (tracking). If a bar code is decoded after the message for that package has been transmitted, the Missed Transmit counter is incremented.

Decode/DSP Counters

Decode/DSP Counters	Description
DSP Codes	Count of the number of barcodes decoded, per laser, by the DSP.
Scan Ints	Number of scan interrupts detected by the DSP.
Queue Size	Current size of the scan data queue within the DSP. This value changes dynamically.
Num Cluster	Current number of DRX clusters in use by the DSP. This value changes dynamically.
Bad Scan	Count of the number of scans in which the data contained formatting errors.
Pipe Error	Count of internal errors on the transfer of scan data from the scan data buffer.
Full Scans	Number of times a scan could not be added to the scan data buffer because the maximum number of scans was exceeded.
Mem Full	Number of times a scan could not be added to the scan data buffer because the memory was full.
ScanTooLong	Number of times a scan was skipped because it contained too many transitions.
Max Clusters	Number of times, the maximum number of DRX clusters was exceeded.

ARM and DSP Restarts Counters

	Description
ARM Restarts	Number of times the ARM processor has restarted. This typically means the hardware watchdog timer expired causing the ARM processor to restart.
DSP Restarts	Number of times the DSP processor has been restarted. Typically, this happens if the ARM suspects the DSP has "locked up" for any reason.

Message Log View

The **Message Log** contains various text messages that have been logged by the AL5010 software. You can view these messages by clicking the Message Log button. You can also enter **DISPMSGLOG** in the command field and click **Send**.

The messages contained in this log typically reflect significant events.

Update Firmware



CAUTION: Used to reload AL5010 reader firmware. This function should only be performed under the guidance of Accu-Sort Technical Support.

Use **Update Firmware** to reload the reader firmware.
CAUTION: This function should only be performed under the guidance of Accu-Sort Technical Support.

To Extract Image	To Burn Flash
<ol style="list-style-type: none"> 1. Click Extract Image 2. In Save as window, save the image (*.as) files to your computer. The graphic on-screen indicates Extract Image is in-process. 3. A message will appear when Extract Image is complete. 	<ol style="list-style-type: none"> 1. Click Browse button. 2. In Open window, open an image file (*.as) to burn to flash. Click Burn Flash button. The graphic on-screen indicates Burn Flash is in-process. 3. A message will appear when Burn Flash is complete. 4. Reboot (cycle power) AL5010.

Diagnostics > Update Firmware

Extracting an Image:

1. Click the **Extract Image** button.
2. The **Save As** window enables you to save image (*.as) files.

Burning an Image to Flash:

1. Click the **Burn Flash** button.
2. The **Open** window enables you to open an image file (*.as*)
3. Burn the image file to flash.

Troubleshooting

The following PCS (problem/cause/solution) tables are designed to assist you in troubleshooting the more common events that may occur during installation and operation of your AccuLazr AL5010.

PCS Troubleshooting

Problem	The POLARITY LED in the wiring base is RED.
Cause(s)	Wiring from the power supply to the INPUT POWER terminal block is incorrectly wired.
Solution(s)	<p>IMPORTANT: DO NOT install the scan head if polarity LED is RED.</p> <ol style="list-style-type: none"> 1. Correct the polarity problem by swapping the wires at the INPUT POWER terminal block. 2. Confirm power polarity is correct (GREEN LED). 3. Install the scan head. (See <i>Chapter 3</i>.)
Problem	There is no laser light exiting from the AL5010 when power is activated.
Cause(s)	<p>Have the laser(s) been shut off? No power is provided to the AL5010.</p>
Solution(s)	<ol style="list-style-type: none"> 1. Check to ensure power is properly connected. 2. Check to see if AL5010 Status LED turns ON. 3. Confirm power supply functioning. 4. Remove AL5010 scan head from wiring base. 5. Verify Power LED in wiring base is GREEN. 6. If Power LED is RED, polarity is swapped. 7. If Power LED is OFF, check wiring at the INPUT POWER terminal block. 8. Replace the power supply if wiring was correct. 9. Reassemble AL5010 scan head to wiring base.
Problem	The AL5010 is not reading bar codes.
Cause(s)	<p>Code type is not enabled or wrong code length. Code passes by at too large an angle (tilt, pitch, skew). All codes have very poor print quality.</p>
Solution(s)	<ol style="list-style-type: none"> 1. Enable code type or correct code length. 2. Make sure laser beam is ON when code passes by. 3. Verify correct bar code parameters are enabled. 4. Enable TEST MODE. (Use the AL5010 control panel button) 5. Hold code in the scan line. 6. Verify the AL5010 is reading the code. 7. Correct any tilt, pitch, or skew problems. 8. Remedy bar code printing problems.

PCS Troubleshooting (continued)

Problem	The AL5010 is experiencing poor read rate.
Cause(s)	Poorly printed bar codes. Scan head window is dirty. Codes passing by at too large an angle (tilt, pitch, skew).
Solution(s)	<ol style="list-style-type: none"> 1. Confirm the quality of bar code printing is good enough to read. Correct any print quality issues. 2. Clean scan head window as defined Chapter 7. 3. Check reading distance with a known good quality sample bar code. 4. Enable TEST MODE. (Use the AL5010 control panel button.) 5. Hold code in the scan line. 6. Verify the AL5010 is reading the code. 7. Correct any tilt, pitch, or skew problems.
Problem	The AL5010 is experiencing poor read rate in hardware trigger.
Cause(s)	Photoeye is not adjusted properly or requires alignment.
Solution(s)	<ol style="list-style-type: none"> 1. Verify that the photoeye is blocked the entire time the reader's laser is scanning the bar code. 2. Adjust the photoeye as necessary. (See <i>Verify Photoeye Operation in Chapter 7.</i>) <p>NOTE: For non-tracking applications only.</p>
Problem	HOST is not receiving serial host message.
Cause(s)	Improper wiring between host and reader. Incorrect configuration settings.
Solution(s)	<ol style="list-style-type: none"> 1. Is the AL5010's RX/TX LED flashing GREEN? 2. If yes, check the serial cable wiring at the wiring base's SERIAL COM terminal block and at the HOST. 3. If no, verify AL5010 trigger input and trigger configuration. 4. View the Message Monitor to verify the AL5010 is transmitting data from the SERIAL COM port. (See <i>Diagnostics > Monitor.</i>)
Problem	AL5010 reads bar codes, but transmits a NO READ message. (Tracking Applications Only)
Cause(s)	Improper tracking configuration
Solution(s)	<ol style="list-style-type: none"> 1. Check for "Code Lost" messages using diagnostics. 2. If "Code Lost" messages are present, check the tracking configuration. (See <i>Tracking.</i>) 3. Correct as needed.
Problem	Cannot connect configuration PC running to the AL5010's Ethernet port.
Cause(s)	Improperly configured Ethernet port on configuration PC
Solution(s)	<ol style="list-style-type: none"> 1. Verify network port configuration on PC. 2. Port on PC must be configured for a static IP address.

Discovering the IP Address

If you don't know the IP address for the AL5010 unit, it can be found in two ways.

To Discover the IP Address Using Recovery Mode:

1. Unplug the power to the AL5010 system.
2. Hold down the “!” button on the back of the reader while you restore power.
3. Release the button. The LEDs should strobe from 5 to 1 and the status LED will be RED indicating that the unit is in Recovery Mode.
4. Open a browser and type 192.168.3.100 in the address bar.
5. The AL5010 recovery screen opens. The screen displays the IP address for the unit as well as the user name and password for the User Interface.

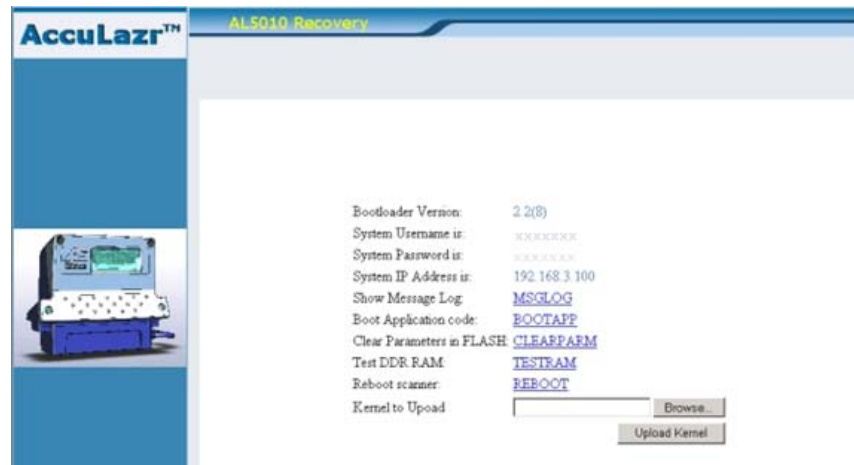

6. Note the IP address for the unit and click REBOOT. The AL5010 reboots and the AL5010 Login screen opens.

To Discover the IP Address Using a Terminal Emulation Program:

1. Connect a laptop computer to one of the serial blocks in the interface module (Basic or Enhance) using a serial cable with flying leads (See the *Electrical Installation* section of this manual).



NOTE: Make sure the baud rate, stop bits, etc match the serial port to which you are connected.

2. Launch a terminal emulation program on your laptop computer (i.e.: HyperTerminal, Tera Term, etc.)
3. Type IpAdDr in the terminal emulation program. If everything is set up correctly, the IP address will be displayed.



NOTE: Since these processes are performed with a direct connection to the individual reader, there are no security issues.

9 Service

There are a limited number of field-replaceable units (FRUs) that are part of the AL5010. In most cases, components should be replaced with a matching recommended spare part (RSP).

Service procedures are divided into two skill levels:

- Customer technicians (with some training from Accu-Sort)
- Accu-Sort Trained and Authorized Service Technicians only

All AL5010 accessories and options are considered customer technician field-replaceable units (FRUs).

The field-replaceable units (FRUs) are identified in this chapter.

Replacement Procedures



CAUTION: This symbol indicates you are about to perform an action involving, either a dangerous level of voltage, or to warn against an action that could result in damage to devices or electrical shock. Please follow necessary procedures as outlined in *Chapter 2, Safety*.



ESD CAUTION: This symbol identifies a procedure that requires you take measures to prevent Electrostatic Discharge (ESD) e.g., use an ESD wrist strap. Circuit boards are most at risk. Please follow ESD procedures as outlined in *Chapter 2, Safety*.

External Devices

To replace any external devices, reference the installation procedures provided in Chapter 3 and Chapter 4.

Field Replaceable Units (FRUs)

Replacement procedures for field-replaceable units (FRUs) that may be performed by customer technicians are provided with the replacement part. They are also available online with 'how to' video clips at:

http://www.accusort.com/about/regform_downloads_al5010.php



CAUTION: An end user or systems integrator with basic electromechanical and technical skills may perform the removal and replacement of the field replaceable units (FRUs) listed below. However, Accu-Sort training is recommended. Contact Customer Service at 1-800-BAR-CODE to schedule training that fits your needs.

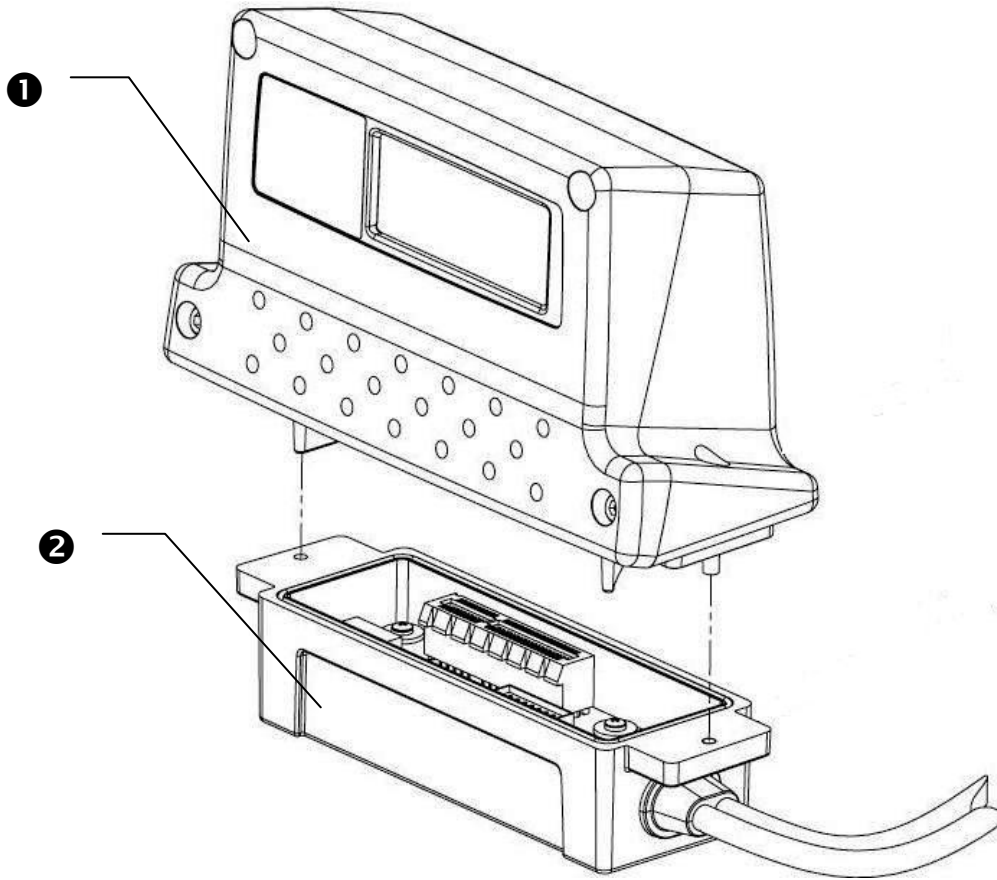

FRU Guide	Spare Part Number	Replacement Assembly Descriptions	
AL5010 Bar Code Reader			
❶	1000070389	1000067750	Scan Head (1L-SD) 1-laser, standard density
		1000067751	Scan Head (1L-HD) 1-laser, high density
		1000067752	Scan Head (1L-NHD) 1-laser, near focus, high density
		1000067753	Scan Head (2L-SD) 2-laser, standard density
		1000067754	Scan Head (2L-HD) 2-laser, high density
		 NOTE: For Adjustable Raster versions or units with custom software installed, please contact Customer Service at 1-800-BAR-CODE to obtain your correct field replaceable units. Please have the unit serial number or order E-number available when you contact Accu-Sort.	
❷	1000070388	0111623001	Mounting Base 1-meter cable
		0111623002	Mounting Base 3-meter cable

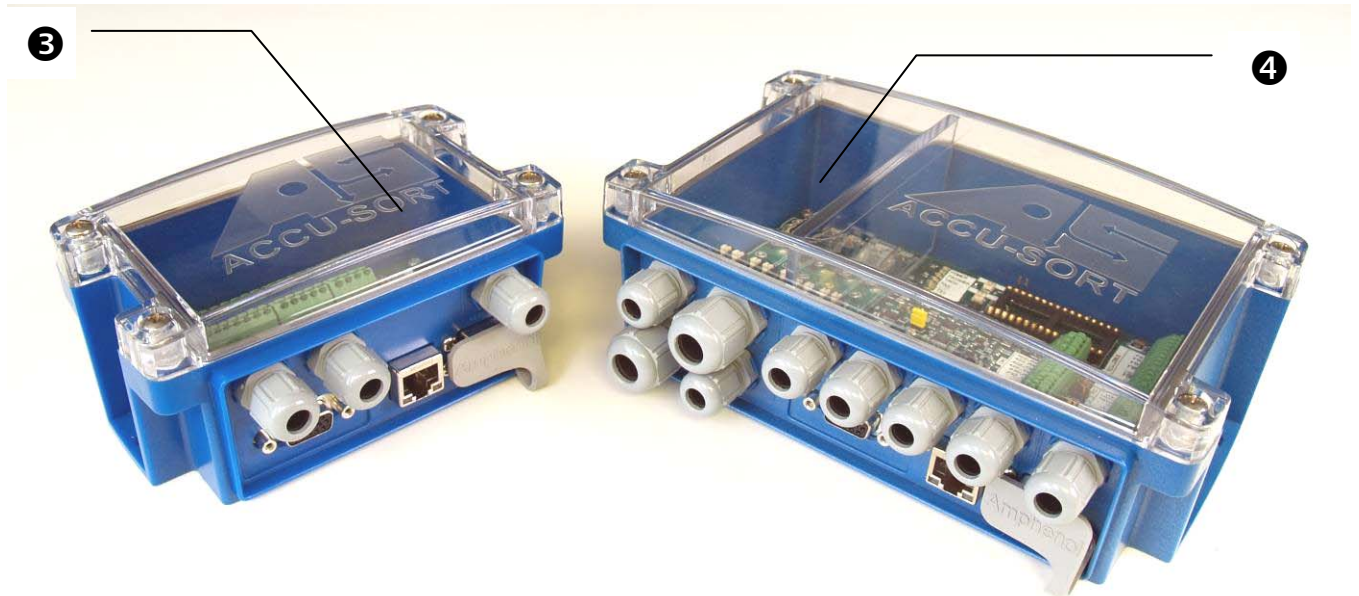

FRU Guide	Spare Part Number	Replacement Assembly Descriptions
AL5010 Interface Module		
③	1000070391	0111631001 Basic Interface Module Trig, Ethernet, (1) serial port (RS232/422 selectable)
④	1000070384	0111633001 Enhanced Interface Module with DeviceNet Tach, Trig, Ethernet, (2) serial port (RS232/422 selectable), (4) I/O
		0111633002 Enhanced Interface Module with DeviceNet Tach, Trig, Ethernet, (2) serial port (RS232/422 selectable), (4) I/O
		0111633003 Enhanced Interface Module with Profibus Tach, Trig, Ethernet, (2) serial port (RS232/422 selectable), (4) I/O
1000070385	1000068248	DeviceNet Replacement Module (Anybus-IC 32-pin)
	1000068247	Profibus Replacement Module (Anybus-IC 32-pin)
1000070386	1000056135	DC Input Module (White): 3.3-32 VDC (32 mA)
	1000056136	DC Output Module (Red): 3-60 VDC (3 A max.)
	1000056137	AC Output Module (Black): 12-42 VACPeak (3 A max.)
Other FRUs		
1000070387	1000020569	Trigger Photoeye, flying leads
1000070390	1000066479	Tachometer, programmable, 8-30 VDC
N/A	0111628001	Power Supply 40 Watt, 12 VDC

Notes:

Specifications

AccuLazr™ AL5010 Technical Specifications



Characteristic Name	Description
(1) Scan Head*	Mid Range Laser Bar Code Reader, AccuLazr™ AL5010
	Line Scan
	Min Bar (mil)
	Depth of Field mm [inch]
	Scans/ Second
	Part Number
1 Laser, Standard Density	1000067750
1 Laser, High Density	1000067751
1L, High Density, Near Focus	1000067757
2L, Low Density, High Pitch	1000067753
2 Laser, High Density	1000067754
Optional Adjustable Raster	1000071308
	Adjustable 20° above and below 0° (center); oscillating mirror
(2) Mounting Base/Cable	1 meter cable (0111623001); 3 meter cable (0111623002)
Size	H 104 mm [4.10"] x W 130.8 mm [5.15"] x D 49.9 mm [1.96"]
Weight	Scan Head: 0.45 kg [1.0 lb] Mounting Bracket: 0.14 kg [0.3 lb] Mounting Base: 0.25-0.34 kg [0.56-0.75 lb]
Enclosure	Powder-coated cast aluminum, high-impact plastic, rated for IP65
Temperature	Operating: 0° to +40° C [+32° to +104° F] Storage: -20° to +70° C [-4° to +158° F]
Relative Humidity	10% - 90% non-condensing
Laser Type	Visible laser diode 650 nm (Class 1)
Power Requirement	12-28 VDC (power supplies available from Accu-Sort)
Power Consumption	< 25W
Visual Indicators (LEDs)	Status, Trigger, Read, RX/TX, Network, Link; read quality (5 LEDs)
Bar Code Types	All standard 1D symbologies
Connectors (Mounting Base)	15-pin "D" Scanner connector, RJ45 connector for Ethernet
Communications	On-board EtherNet/IP, Ethernet TCP/IP, Serial RS232/RS422, 4 programmable I/O relays, DeviceNet, Profibus (see <i>AccuLazr Basic and Enhanced Interface Module datasheets</i>)
Options	Universal Mounting Bracket (0111620001) Basic and Enhanced Interface Modules (see <i>datasheets</i>)
Reliability	> 50,000 hours MTBF @ 25° C [77° F]
Service Options	Installation assistance and on-site training
Warranty	1-year limited, parts and labor
Compliance	UL, cUL, FCC (Class A), 21CFR1040, IEC-60825-1, 007010S

Accu-Sort reserves the right to change product specifications without notice.



AccuLazr™ Basic Interface Module Technical Specifications

Characteristic	Description
Name	AccuLazr™ Basic Interface Module (0111631001)
Size	H 92.5 mm [3.64"] x W 136.4 mm [5.37"] x D 65.0 mm [2.56"]
Weight	Basic Interface Module: 0.317 kg [0.7 lbs] Power Supply: 0.498 kg [1.1 lbs]
Temperature	Operating: 0° to +40° C [+32° to +104° F] Storage: -20° to +70° C [-4° to +158° F]
Relative Humidity	10-90% non-condensing
Enclosure	High-impact plastic, rated for IP54
Power Requirements	12-28 VDC (power supplies available from Accu-Sort)
Power Consumption	< 25 W (max.)
Power Supply	12-28 VDC (< 25W) (0111628001) Power Cord: 125V, 10A, 2.3 meter [7.6 ft] long (0102414001) 230V, 10A, 2.4 meter [8.0 ft] long (0102713001)
Visual Indicators	LEDs – Power, Trigger
Connections	Terminal Blocks rated for 16-24 AWG wire Standard RJ45 and 15-pin 'D' connections from mounting base
Communications	Ethernet, Serial RS232/RS422 (selectable)
Reliability	> 50,000 hours MTBF @ 25° C [77° F]
Service Options	Installation assistance and on-site training
Warranty	1-year limited, part and labor
Compliance	UL, cUL, FCC (Class A), 21CFR1040, IEC-60825-1, 002016/03 (See Compliance table in this appendix.)

Accu-Sort reserves the right to change product specifications without notice.

AccuLazr™ Enhanced Interface Module Technical Specifications



Characteristic	Description
Name	AccuLazr™ Enhanced Interface Module
Size	133.6 mm [5.26"] H x 191.4 mm [7.54"] W x 67.0 mm [2.64"] D
Weight	Enhanced Interface Module: 0.589 kg [1.3 lbs] (no I/O modules) Power Supply: 0.498 kg [1.1 lbs]
Temperature	Operating: 0° to +40° C [+32° to +104° F] Storage: -20° to +70° C [-4° to +158° F]
Relative Humidity	10-90% non-condensing
Enclosure	High-impact plastic, rated for IP65
Power Requirements	Input: 12-28 VDC (power supplies available from Accu-Sort)
Power Consumption	< 25 W (max.)
Power Supply	12-28 VDC (< 25W) (0111628001) Power Cord: 125V, 10A, 2.3 meter [7.6 ft] long (0102414001) 230V, 10A, 2.4 meter [8.0 ft] long (0102713001)
Visual Indicators	LEDs – Power, Trigger, Tach, RX/TX1-2, DeviceNet, Profibus, I/O 1-4
Connections	Terminal Blocks rated for 20-24 AWG wire (power is 16-24 AWG) Standard RJ45 and 15-pin 'D' connections from mounting base
Communications	Serial RS232/RS422 (2), Ethernet TCP/IP, DeviceNet, Profibus and up to 4 programmable I/O relay modules
Options	Tachometer: Programmable, 8-30VDC, 20 ft. cable (1000066479) General Mounting (1000020567) Extrusion Mounting (1000020568) Photoeye: incl. hardware/reflector (1000020569) I/O Modules: Input 3.3-32VDC (1000056135) Output 3-60VDC (1000056136) Output 12-42VACPeak (1000056137)
Reliability	> 50,000 hours MTBF @ 25° C [77° F]
Service Options	Installation assistance and on-site training
Warranty	1-year limited, part and labor
Compliance	UL, cUL, FCC (Class A), 21CFR1040, IEC-60825-1, 002016/03 (See Compliance table in this appendix.)

Accu-Sort reserves the right to change product specifications without notice.

Power Supply for AL5010



Characteristic	Description
Dimensions	L 4.65" [118 mm] x W 1.36" [34.5 mm] x H 2.05" [52 mm]
Weight	0.6 lbs. [0.275 kg]
Temperature	Operating: 0° to +70° C Storage: -40° to +85° C
Relative Humidity	5-95% non-condensing
Enclosure	ABS plastic, Rated for IP40
Power Requirements	Input: 90-264 VAC / 0.5A typical, 1.0A max. @ 120 VAC Output: Max. 250mA Load
Power Consumption	< 40 W
Connections	Male IEC (available with either domestic or international power cord)
Compliance	UL, cUL, CE, FCC (Class A) (See Compliance table.)



Output Modules

Part Number	1000056136	1000056137
Maximum Line Voltage	60 VDC	42 VAC
Minimum Line Voltage	3.0 VDC	12 VAC
Maximum Peak Off State Voltage	60 VDC	42 VAC peak
Maximum Peak Off State Leakage	1.0 mA	2.5 mA RMS
Static off-state dv/dt	--	200 V/usec
Maximum On-State Current	0.5 A DC	0.5 A RMS
Minimum On-State Current	10 mA DC	50mA RMS
Maximum 1 Cycle Surge	--	4 A peak
Maximum 1 Second Surge	1.5 A DC	--
Peak On-State Voltage	1.5 V DC	1.6 V peak



***NOTE:** Relay modules are only for connection to SELV, LPS power source and shall also meet the requirements for Class 2.

Input Module

Part Number	1000056135 *
Maximum Input Voltage	32 VDC
Minimum Input Voltage	3.3 VDC
Input Resistance	1 k ohm
Maximum Input Current	32mA DC@ 32 VDC
Drop Out Current	1.0 mA DC
Allowable Off-State Input Current	1.0 mA DC
Allowable Off-State Input Voltage	2.0 VDC

* **NOTE:** Compatible with TTL level voltages.

Certifications



UL Listed

UL Listed to Canadian safety standards

Standard to which conformity is declared:

EN60950: Test Spec: IEC 60950 3RD Edition / (2000) (Information Technology Equipment (I.T.E.), Including Electrical Business Equipment



Standards to which conformity is declared:

FCC 47 CFR, Part 15, subpart B, "Unintentional Radiators"
CLASS A Radiated Emissions and CLASS B Conducted Emissions



Standards to which conformity is declared:

1 Emissions

EN 61000-6-4: 2001

CISPR 11:1999 Radiated Emissions – Class A

CISPR 11:1999 Conducted Emissions – Class A

2 Immunity

EN 61000-6-2: 2001 Electromagnetic Compatibility - Generic Standards - Immunity for industrial environments

EN 61000-4-2:1995, Electromagnetic compatibility (EMC), Electrostatic discharge immunity test

EN 61000-4-3: 2001, (EMC), Part 4 - Section 3: Radiated, radio-frequency electromagnetic field test

EN 61000-4-4:2004, (EMC), Electrical fast transient/burst immunity test

EN 61000-4-5:1995, (EMC), Part 4 - Section 5 Surge immunity test

EN 61000-4-6:2003, (EMC), Part 4 - Section 6 Immunity to conducted disturbances, induced by radio-frequencies

IEC 61000-4-11: 2003, (EMC), Part 4 - Section 11 Voltage dips, short interruptions & variations immunity

IEC 61000-3-2 A14, 3/2000 and 61000-3-3: Harmonic current emissions (Fluctuating and Steady State Harmonics)

ENV 50204: 1995, "(EMC), Radiated, Electromagnetic Field From Digital Radio Telephones-Immunity Test"



C-TICK: N2468, DATALOGIC AUTOMATION PTY, Australia / New Zealand

Read Charts

How to identify the scan head model:

The model type is shown on the serial label.



1L – Indicates a scan head that is using one laser.

2L – Indicates a scan head that is using two lasers.

SD – Identifies a standard density scan head for reading bar codes with minimum bar/space widths of 15 mil+.

HD – Identifies a high density scan head for reading bar codes with minimum bar/space widths of 10 mil+.

NHD – Identifies a near focus, high density scan head for reading bar codes with minimum bar/space widths of 10 mil+.



IMPORTANT: All read charts are subject to change without notice.



NOTE: An Ultra-Near Focus model is also available with a depth of field from 4 to 20 inches. Please contact Accu-Sort Systems for details relating to your application.

Combo Read Chart / Table

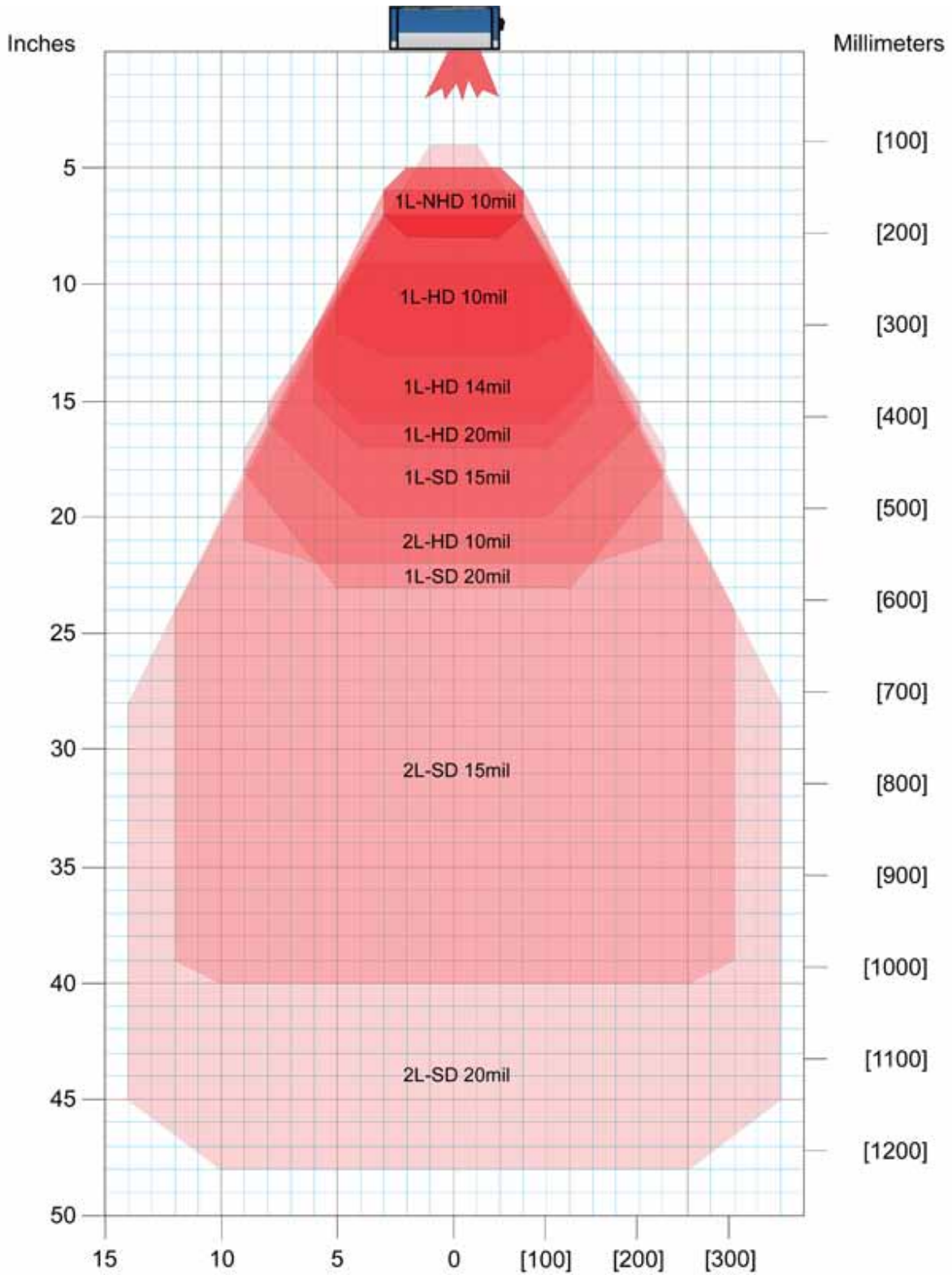

1,200 scans per second (standard) throughout DOF
 ANSI Contrast Grade 84% or greater
 ANSI "Grade A" Print Quality

Pitch not greater than +/- 15 °
 Skew not greater than +/- 15 °
 Tilt not greater than +/- 45 °

AL5010-1L NHD: 1 Laser, Near Focus High-Density

Scan Head Part Number 1000067752

10 mil code

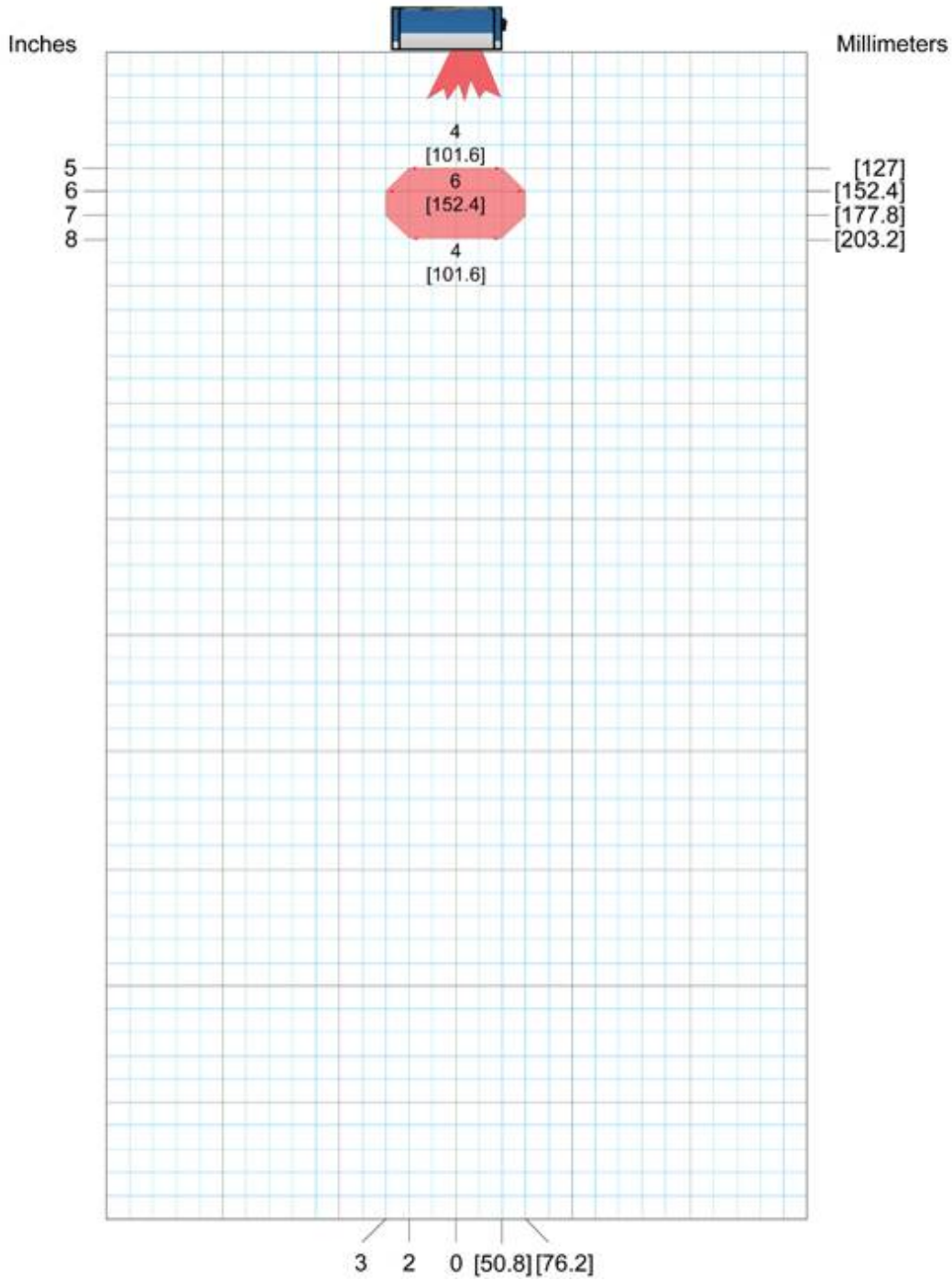

1,200 scans per second (standard) throughout DOF
ANSI Contrast Grade 84% or greater
ANSI "Grade A" Print Quality

Pitch not greater than +/- 15 °
Skew not greater than +/- 15 °
Tilt not greater than +/- 45 °

AL5010-1L HD: 1 Laser, High-Density

Scan Head Part Number 1000067751

10 mil code

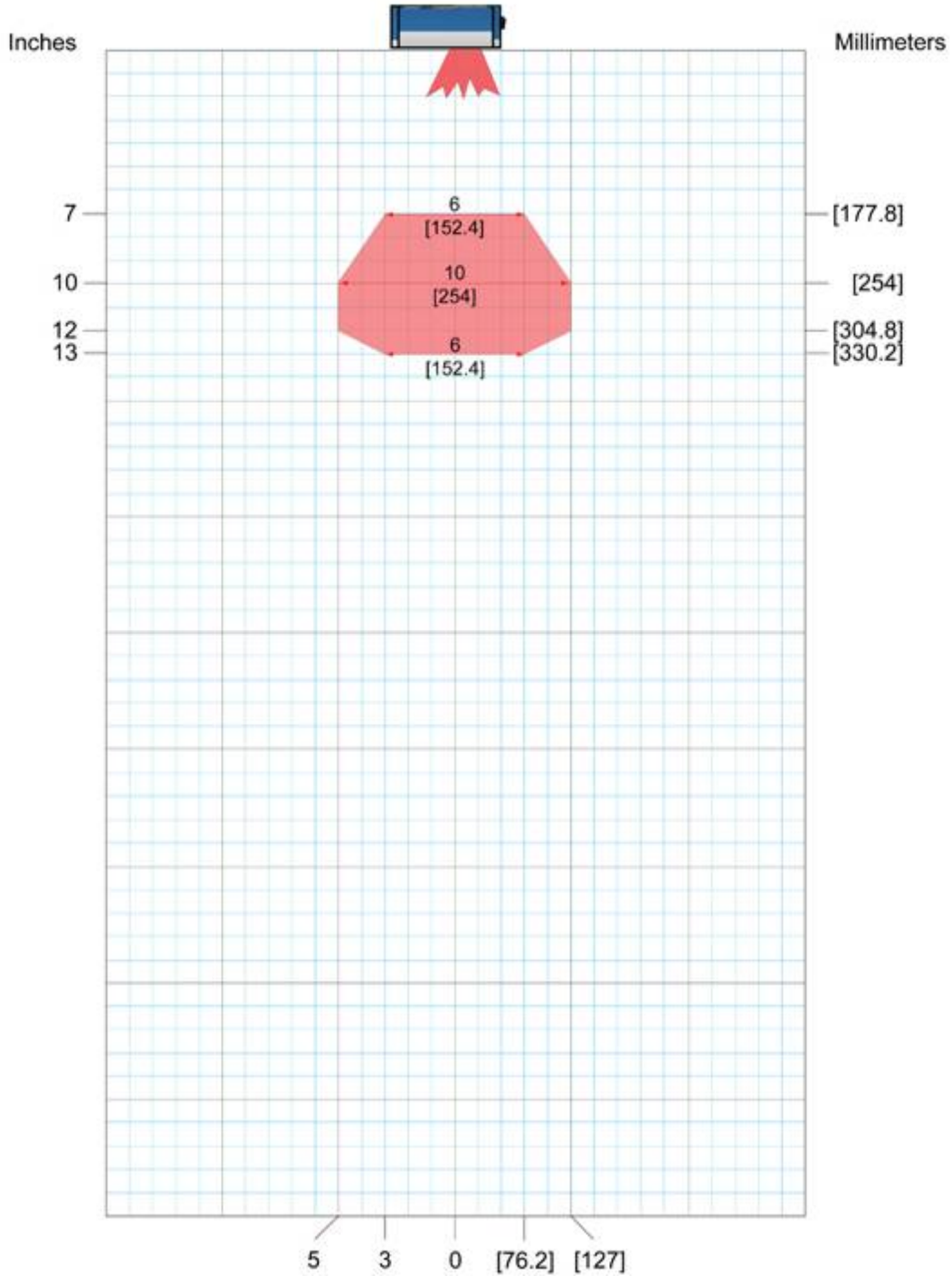

1,200 scans per second (standard) throughout DOF
 ANSI Contrast Grade 84% or greater
 ANSI "Grade A" Print Quality

Pitch not greater than +/- 15 °
 Skew not greater than +/- 15 °
 Tilt not greater than +/- 45 °

AL5010-1L HD: 1 Laser, High-Density

Scan Head Part Number 1000067751

14 mil code

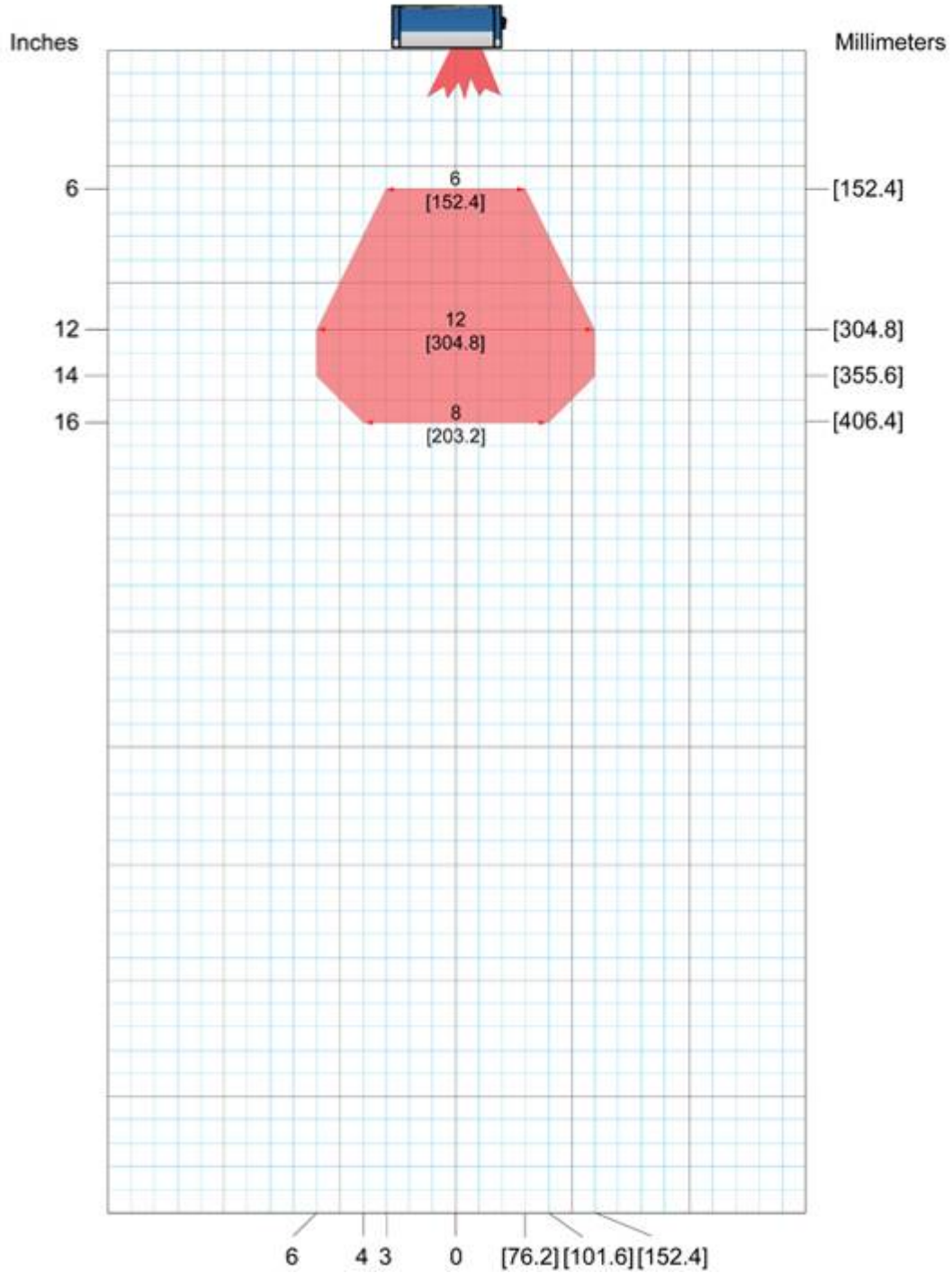

1,200 scans per second (standard) throughout DOF
ANSI Contrast Grade 84% or greater
ANSI "Grade A" Print Quality

Pitch not greater than +/- 15 °
Skew not greater than +/- 15 °
Tilt not greater than +/- 45 °

AL5010-1L HD: 1 Laser, High-Density

Scan Head Part Number 1000067751

20 mil code

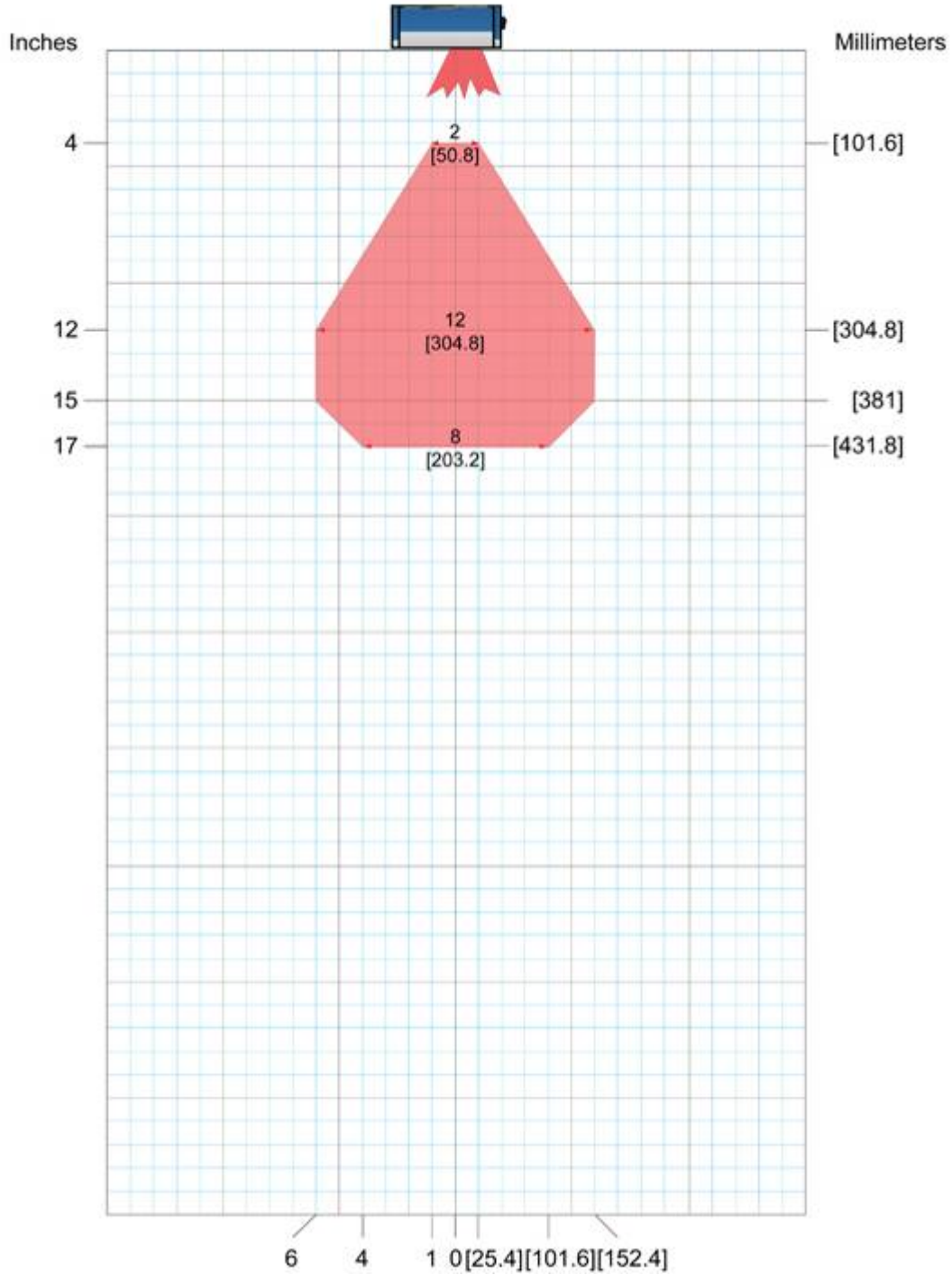

1,200 scans per second (standard) throughout DOF
 ANSI Contrast Grade 84% or greater
 ANSI "Grade A" Print Quality

Pitch not greater than +/- 15 °
 Skew not greater than +/- 15 °
 Tilt not greater than +/- 45 °

AL5010-1L SD: 1 Laser, Standard Density

Scan Head Part Number 1000067750

15 mil code

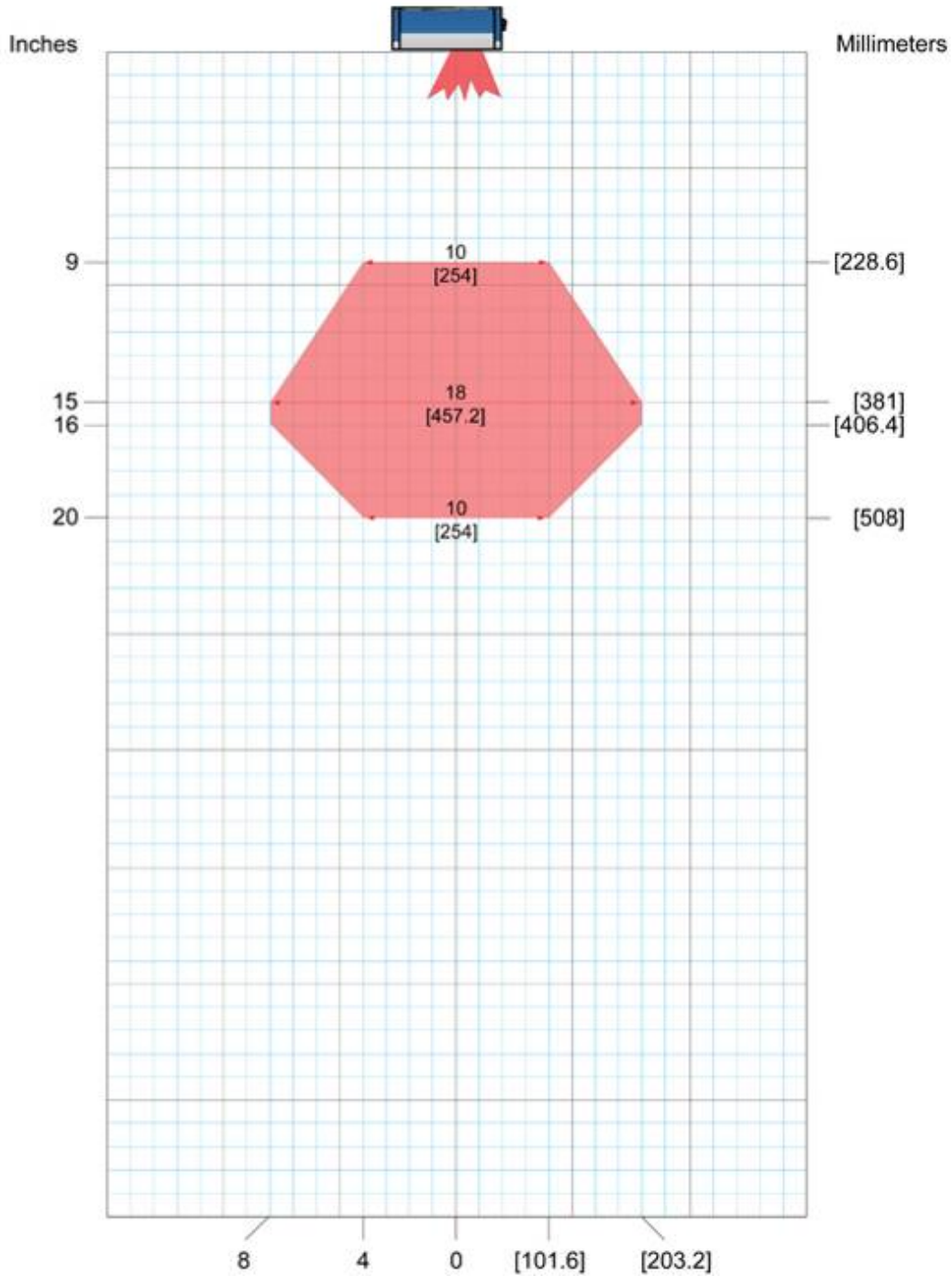

1,200 scans per second (standard) throughout DOF
ANSI Contrast Grade 84% or greater
ANSI "Grade A" Print Quality

Pitch not greater than +/- 15 °
Skew not greater than +/- 15 °
Tilt not greater than +/- 45 °

AL5010-1L SD: 1 Laser, Standard Density

Scan Head Part Number 1000067750

20 mil code

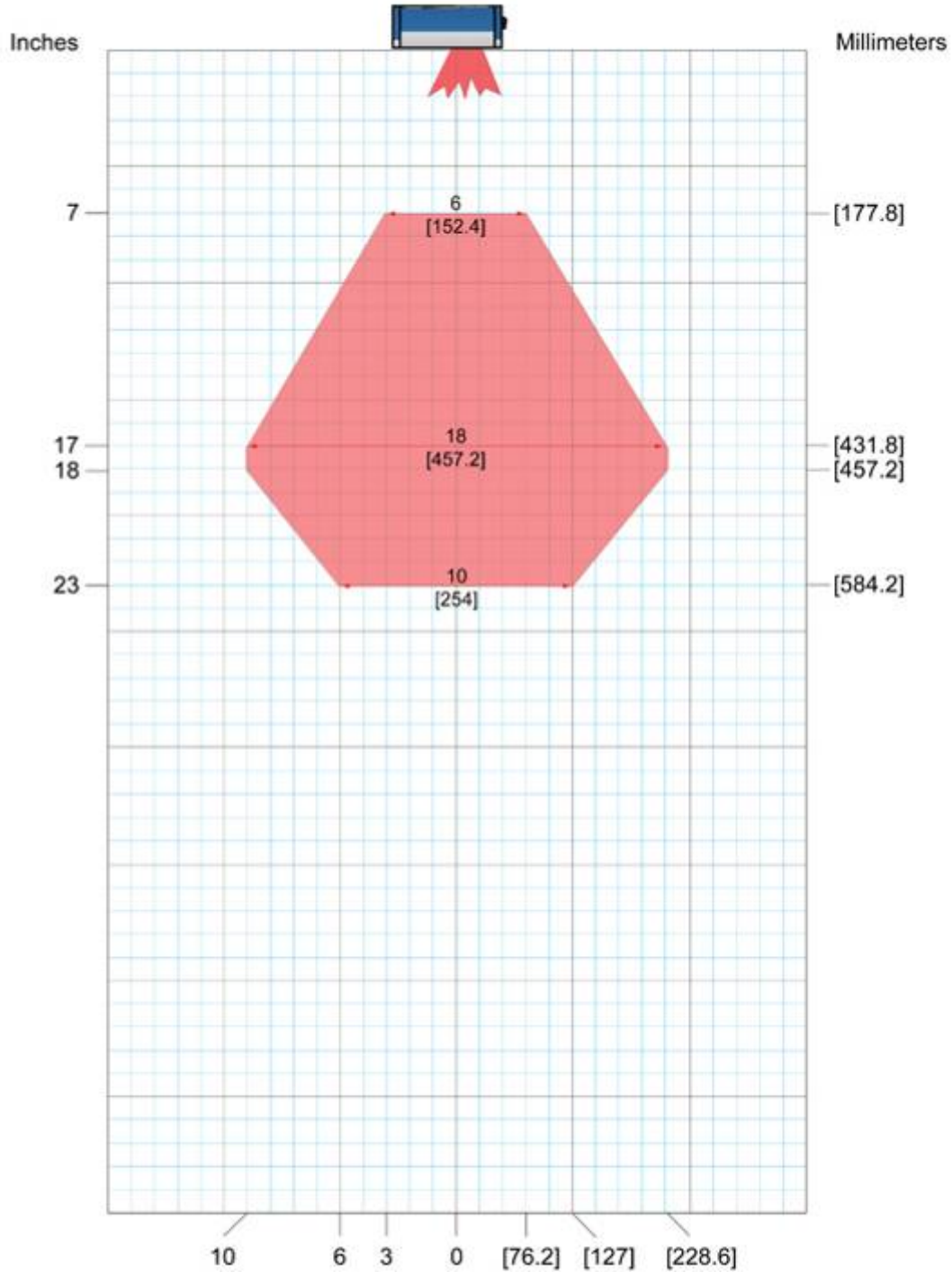

1,200 scans per second (standard) throughout DOF
 ANSI Contrast Grade 84% or greater
 ANSI "Grade A" Print Quality

Pitch not greater than +/- 15 °
 Skew not greater than +/- 15 °
 Tilt not greater than +/- 45 °

AL5010-2L HD: 2 Lasers, High Density

Scan Head Part Number 1000067754

10 mil code

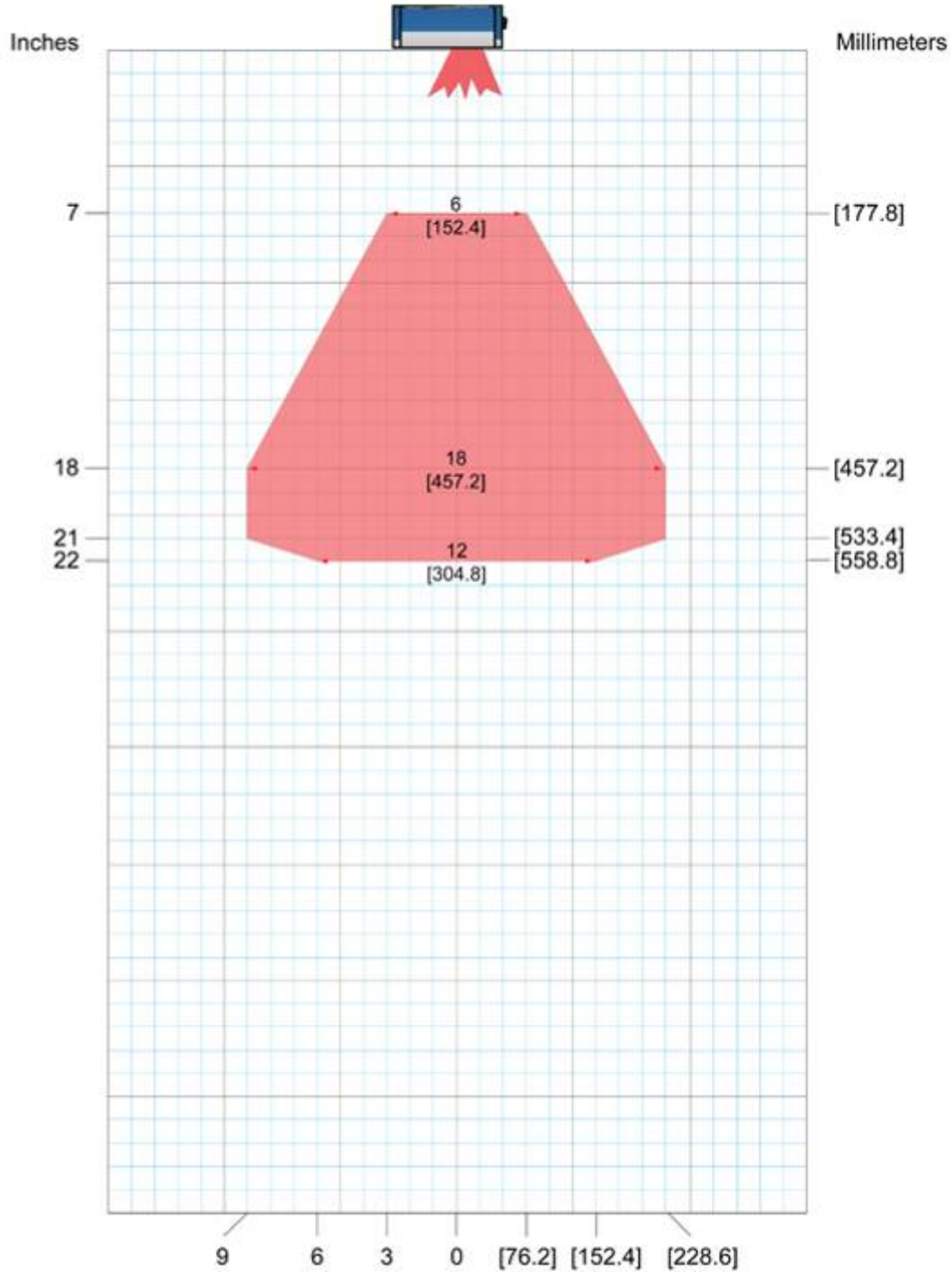

1,200 scans per second (standard) throughout DOF
 ANSI Contrast Grade 84% or greater
 ANSI "Grade A" Print Quality

Pitch not greater than +/- 15 °
 Skew not greater than +/- 15 °
 Tilt not greater than +/- 45 °

AL5010-2L SD: 2 Lasers, Standard Density

Scan Head Part Number 1000067753

15 mil code

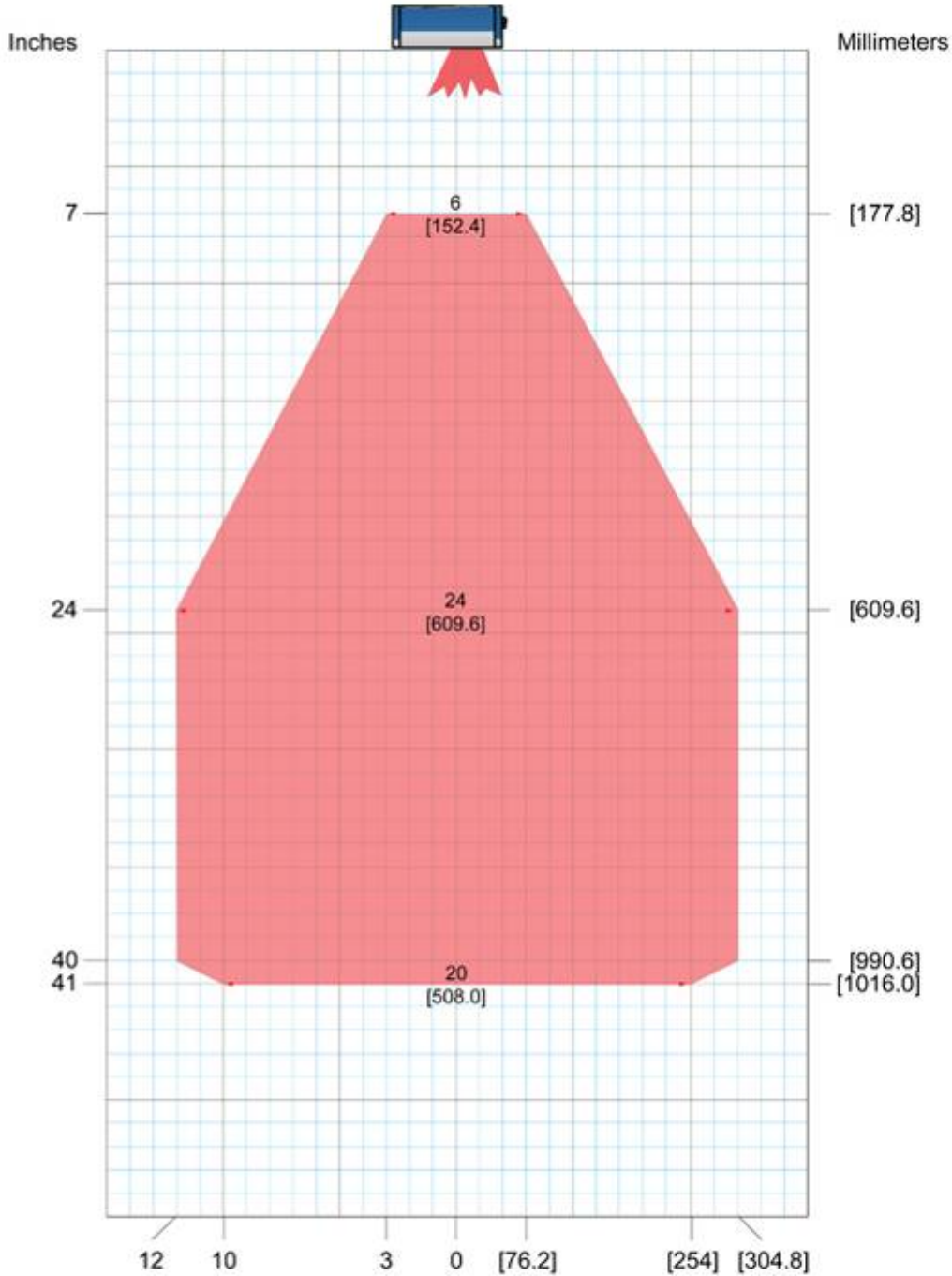

1,200 scans per second (standard) throughout DOF
 ANSI Contrast Grade 84% or greater
 ANSI "Grade A" Print Quality

Pitch not greater than +/- 15 °
 Skew not greater than +/- 15 °
 Tilt not greater than +/- 45 °

AL5010-2L SD: 2 Lasers, Standard Density

Scan Head Part Number 1000067753

20 mil code

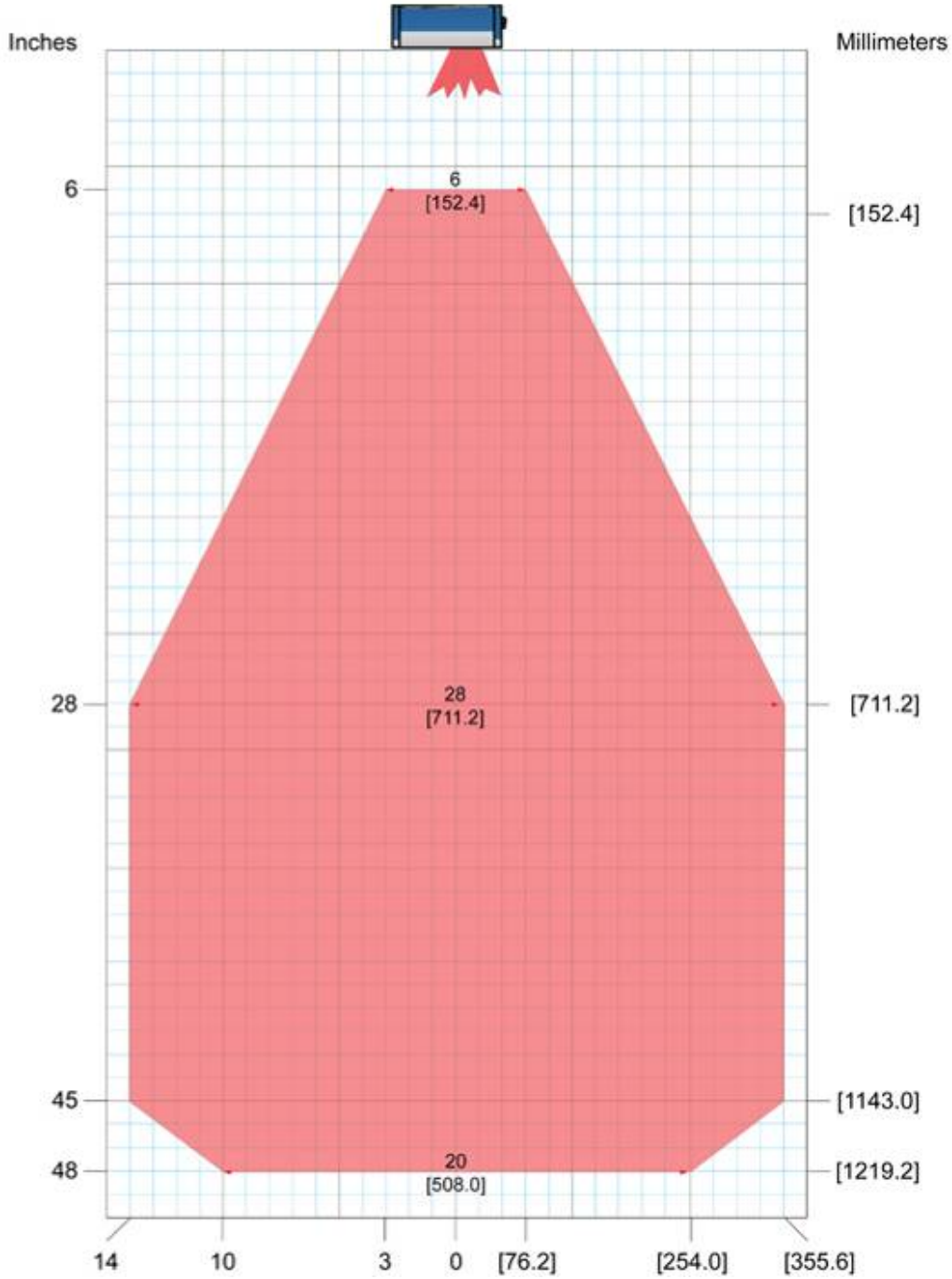

1,200 scans per second (standard) throughout DOF
 ANSI Contrast Grade 84% or greater
 ANSI "Grade A" Print Quality

Pitch not greater than +/- 15 °
 Skew not greater than +/- 15 °
 Tilt not greater than +/- 45 °

Notes:

AccuLazr™ User Interface

This appendix provides tables of parameter definitions and descriptions for each screen provided in the AccuLazr User Interface.



AccuLazr User Interface Login Screen (current version 6.0)



AccuLazr User Interface Homepage



IMPORTANT: Step-by-step procedures are provided in Chapter 5.

Modify Settings

Use the Modify Settings menu tree selections during initial setup to configure your AL5010 Mid-Range Laser Bar Code Reader. If necessary, you can later make modifications to the reader's configuration using the same menu selections, including:

- Bar Codes / Bar Code Groups
- Modulo Checks
- Stripping and Padding
- Match Codes
- Serial Communications
- Network Communications
- Message Definitions
- Trigger
- Relay
- Tracking
- FAST Monitor Setup
- Advanced Settings

For additional information, click the  button

Modify Settings

The Modify Settings main page describes the items available in its menu tree.



Modify Settings > Configuration

The screenshot shows a configuration window with the following sections:

- Reader Information:** Fields for Reader Name (AL5010), Reader Model (2L Standard Density), Serial Number (27), Software Name/Revision (AL5010 1.2(41)), Decode Software Name/Revision (DRXSTD 1.4(29)), and FPGA Device Id/Revision (0x3c40 38.0(50)).
- Configuration Options:** Scan Rate (600-1200) set to 1000, Field of View (2-54 degrees) set to 54. A note states: "Modifying the scan rate from the factory setting can adversely affect the AL5010 performance." There is a checkbox for "Enabled Trigger/Track Controlled Laser" (unchecked) and a Units dropdown set to "ENGLISH".
- Control Panel Options:** A checked checkbox for "Enable Control Panel Buttons" and a dropdown for "Use Button 1 For Test Mode".
- Network Access Options:** Fields for Username, New Password, and Confirm Password.

Buttons for "Update" and "Reset" are located at the bottom right.

Modify > Configuration Descriptions

Selection	Definition
Reader Information	Reader Name – User-defined reader name (up to 15 characters). Useful when it is necessary to identify multiple AL5010 readers within the same building or application.
	Reader Model – Displays the model of the reader (AL5010-IL, AL5010-2L, etc.).
	Serial Number – Displays the serial number of the reader.
	Software Name/Revision – Displays the installed software name and revision number.
	Decode Software Name/Revision – Displays the installed decode software name and revision number.
	FPGA Device Id/Revision – Displays the FPGA (field-programmable gate array) device name and revision number.
Configuration Options	Scan Rate (600-1200) – Allows you to change the scan rate.  WARNING: Modifying the scan rate from the factory setting can adversely affect the AL5010 performance.  NOTE: Changing scan rate and then saving parameters causes the AL5010 to reboot.
	Field of View (2-54 degrees) – The field of view may be defined within stated parameters.
	Enabled Trigger/Track Controlled Laser – Enabling this function results in the following: <ul style="list-style-type: none"> • Non-Tracking: Lasers turn off whenever "trigger" is not active. • Tracking: Lasers turn off whenever the belt speed is zero or a package has not been detected for two minutes.

Units – Drop-down list allows the units of measure to be set as either English or Metric.

Control Panel Options

Enable Control Panel Buttons – When enabled, select one of the following modes from the drop-down list:

- **Use ! Button For Test Mode:** Activate the test mode by pressing the "!" button.
- **Use ! Button to Learn Match Code:** Unit operates in Test Mode, but the last code read is also stored in the match code table.
- **Use ! Button for Sleep Mode:** Holding the ! button down for seven (7) seconds will put the AL5010 into sleep mode.



NOTE: The “! Button” refers to the button on the back of the AccuLazr bar code reader.

Network Access Options



Username – Enter the username

Password – Enter the password

Confirm Password – Re-enter the password to confirm and set the new password.

Modify Settings > Bar Codes

Modify > Bar Codes Descriptions (Bar Code Tab)

Selection	Definition
Selected Symbologies	<p>Symbology Grid – Displays added bar codes with columns for Symbology, Code Label, Min Length, Max Length, Min Quantity, and Max Quantity.</p> <p>Strip Function Characters – Select to enable. When enabled, function characters are stripped out of the bar code.</p>
Learn Bar Code	Click Learn and then hold the bar code in the scan line to add to the Selected Symbology to the Symbologies listed.
Symbology Type	<p>Code Type – Select a code type from the drop-down list</p> <p>Minimum Length – User-defined minimum bar code character length.</p> <p> NOTE: Some bar codes have a fixed character length that may not be modified.</p> <p>Maximum Length – User-defined maximum bar code character length.</p> <p> NOTE: Some bar codes have a fixed character length that may not be modified.</p> <p>Filter – User-defined bar code filter. This allows a “match pattern” to be specified for a bar code definition. This restricts this code definition to only bar codes that match this pattern.</p> <ul style="list-style-type: none"> Example: Setting “9*” as a filter defines that only bar codes that start with a nine will be accepted. Only one “*” may be entered in the Filter field. <p>Code Label – User-defined name for the selected bar code.</p> <p>Minimum Quantity – User-defined minimum quantity for the bar code.</p>

Maximum Quantity – User-defined maximum quantity for the bar code.

Modulo Check – Select the Modulo check digit setup from the drop-down list. Selections include Modulo 10, Standard Mode 43, and User Defined.

Code Label	Filter
Code 128	
UPC E (12 Characters)	
Codabar	5*

Modify > Bar Codes Descriptions (Filters Tab)

Selection	Definition
Code Filters	Displays user-defined bar code filters added on the Bar Code tab in a grid. The Code Filters grid displays columns for Code Label and associated Filter (if applicable).

Groups No.	Code 128	UPC E (12 Characters)	Codabar
1	<input checked="" type="checkbox"/>	<input checked="" type="checkbox"/>	<input checked="" type="checkbox"/>
2	<input type="checkbox"/>	<input type="checkbox"/>	<input type="checkbox"/>
3	<input type="checkbox"/>	<input type="checkbox"/>	<input type="checkbox"/>
4	<input type="checkbox"/>	<input type="checkbox"/>	<input type="checkbox"/>
5	<input type="checkbox"/>	<input type="checkbox"/>	<input type="checkbox"/>
6	<input type="checkbox"/>	<input type="checkbox"/>	<input type="checkbox"/>
7	<input type="checkbox"/>	<input type="checkbox"/>	<input type="checkbox"/>
8	<input type="checkbox"/>	<input type="checkbox"/>	<input type="checkbox"/>
9	<input type="checkbox"/>	<input type="checkbox"/>	<input type="checkbox"/>
10	<input type="checkbox"/>	<input type="checkbox"/>	<input type="checkbox"/>
11	<input type="checkbox"/>	<input type="checkbox"/>	<input type="checkbox"/>
12	<input type="checkbox"/>	<input type="checkbox"/>	<input type="checkbox"/>
13	<input type="checkbox"/>	<input type="checkbox"/>	<input type="checkbox"/>
14	<input type="checkbox"/>	<input type="checkbox"/>	<input type="checkbox"/>
15	<input type="checkbox"/>	<input type="checkbox"/>	<input type="checkbox"/>
16	<input type="checkbox"/>	<input type="checkbox"/>	<input type="checkbox"/>

Modify > Bar Codes Descriptions (Bar Code Group Tab)

Selection	Definition
Grid View	Displays the defined bar codes along with a column for Groups No. Select check boxes to define bar codes included in a number group.

When more than one bar code type is defined in Bar Code Setup, the **Bar Code Groups** selection becomes available. This enables you to define the valid “groups” of bar codes that are to be transmitted together.

Modify Settings > Modulo Checks

Selection	Definition
User Defined <i>n</i>	<p>Factors – Define weighting factors for determining mod check value.</p> <ul style="list-style-type: none"> • Example: Enter 31 for a 3-to-1 weight.
	<p>Divisor (1-255) – Defines a divisor (i.e., number from 1-255) that is divided into the mod check sum.</p>
	<p>Remain –</p> <ul style="list-style-type: none"> • Checkmark = check digit is remainder of the divided amount. • No checkmark = the number that must be added to the remainder to get the divisor
	<p>Right –</p> <ul style="list-style-type: none"> • Checkmark = Weight string begins from the right • No Checkmark = Weight string begins from the left
	<p>Wrap – If the remainder of the check digit is calculated to be 0:</p> <ul style="list-style-type: none"> • No checkmark = accept 0 as check character • Checkmark = replace the 0 with a 1
	<p>Add – Select to add the most significant digit to the mod check.</p>

Modify Settings > Stripping/Padding

Bar Codes

Available Bar Codes: Code 128 Code Position=1
Min Length=8
Max Length=8

Character Stripping

Transmit All

Strip Selected Character:

Specify the numbers of the characters to be removed (E can be used to specify the end). To remove the first or last characters, an F or L can also be specified along with the number of characters to remove.

For example: F3,5,7-12,L5 will remove the first 3 characters, character 5, character 7 through 12 and the last 5 characters of the bar code. 4-E will strip off every character from position 4 to the end of the bar code.

Characters Padding Before and/or After The Bar Code

No Padding

Add Padding

Pad before bar code by repeating a single character to a fixed length Bar Code Length: 0

Pad after bar code by repeating a single character to a fixed length Bar Code Length: 0

Update Reset

Selection	Definition
Bar Codes	Available Bar Codes – Select a bar code from the drop-down list. The Code Position, Min Length, and Max Length are displayed for the selected bar code.
Character Stripping	<p>Transmits all – Select this option and no characters are stripped.</p> <p>Strip Selected Characters – Select this option to strip our selected characters.</p> <ul style="list-style-type: none"> Example: To strip the first and last character of a code (such as for Codabar w/o start and end) specify F1,L1 for the character stripping.
Characters Padding Before and/or After The Bar Code	<p>No Padding – Select this option if no padding is required.</p> <p>Add Padding – Select this option to add a fixed string of characters to the beginning and/or end of the bar code. The character(s) to be added as padding must be entered in the field next to the Add Padding option group button.</p> <p>Padding Before bar code by repeating a character for a fixed length – Select this option to repeat a specified character before the bar code to create a string of the length specified in the Bar Code Length field.</p> <p>Padding After bar code by repeating a character for a fixed length – Select this option to repeat a specified character after the bar code to create a string of the length specified in the Bar Code Length field.</p>

Modify Settings > Match Code Pattern

Match Code Pattern

Match Code Pattern 1	<input type="text"/>
Match Code Pattern 2	<input type="text"/>
Match Code Pattern 3	<input type="text"/>
Match Code Pattern 4	<input type="text"/>
Match Code Pattern 5	<input type="text"/>
Match Code Pattern 6	<input type="text"/>
Match Code Pattern 7	<input type="text"/>
Match Code Pattern 8	<input type="text"/>
Match Code Pattern 9	<input type="text"/>
Match Code Pattern 10	<input type="text"/>

String matching pattern explanation : "*" represents a string with arbitrary length, "?" represents a single character. Example: ABC*,ABC??FG,??123 and etc...

Selection	Definition
Match Code Pattern	<p>Match Code Pattern <i>n</i> – Enter match code patterns in the space provided.</p> <p>All bar codes are compared to the complete list of Match Codes. If a bar code matches ANY of the codes defined in Match Code settings, it is considered a MATCH. When a match code is read, you can setup your reader to:</p> <ul style="list-style-type: none"> fire a relay output (Example: Activate a diverter) send a user-defined message (Example: Acknowledge match code found) <div style="margin-top: 10px;">  <p>USEFUL TIP: If ANY match code pattern is set to "*" ALL codes will match it</p> </div>

Example Match Code using a 6 character code 39 selected in Modify Settings>Bar Codes:

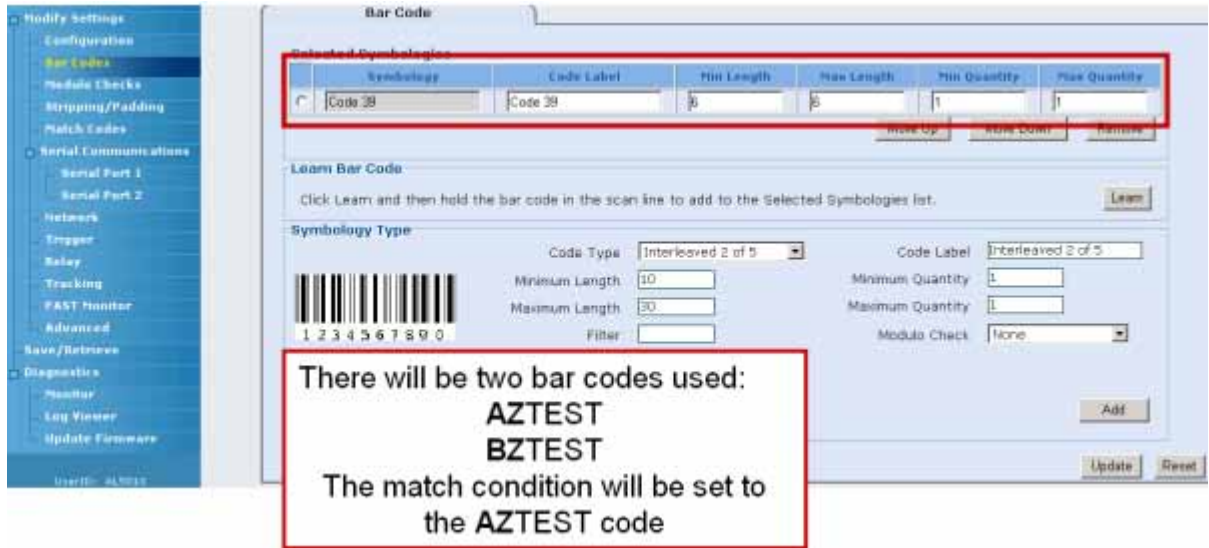

Without any match code enabled the host message data will consist of the data found in the bar code.

In this example the data in the host message will be "AZTEST".

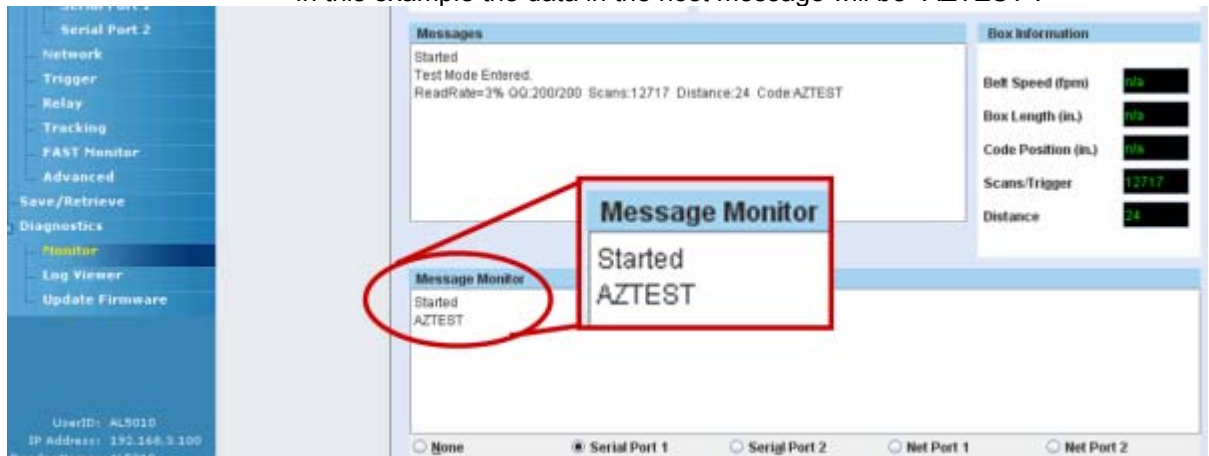

This example is set to match any bar code that begins with AZ. The * indicates that any data after the AZ will be accepted.



- Enter the following options in the Message Definition –Port # 1 field
 - Serial Port # 1 Messages
 - Read
 - Set to **“No Message”**
 - Match
 - Enter appropriate option
 - » This example will send the bar code data
 - Set match to **“Send Barcode”**
 - No Match
 - Set to send **“!”** when the bar code doesn't match

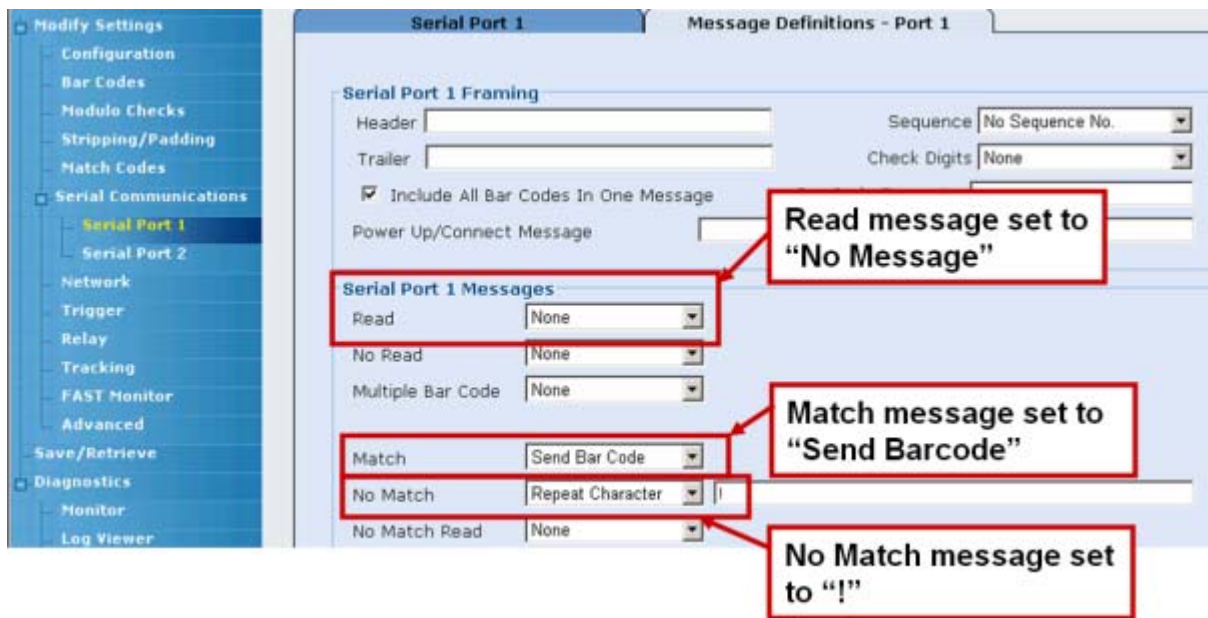

The AL5010 with the relay options can also be set to react to the Match or No Match condition.

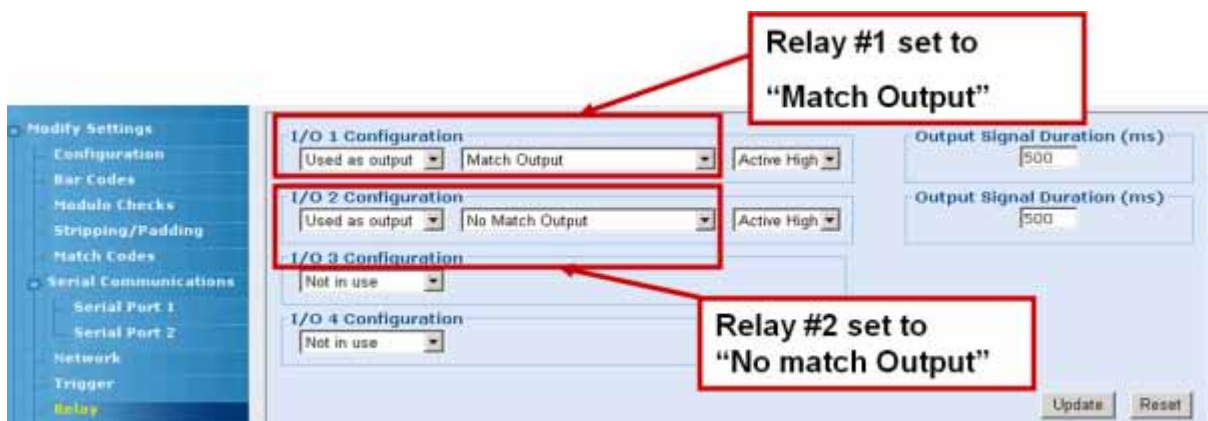

MATCH Results

Relay #1 fired

AL5010 identifies the data as a MATCH

Host message with bar code data

NO MATCH Results

Relay #2 fired

AL5010 does not post the Match message to the bar code data

No Match host message equals !!!!

Modify Settings > Serial Communications

Use the Serial Communications menu tree selections to set the serial port connection parameters including:

- Baud Rate
- Data Bits
- Stop Bits
- Parity
- Flow Control
- Message Format

For additional information, click the  button

The **Modify > Serial Communications** main page describes the items available in its menu tree.

Modify Settings > Serial Communications > Serial Port *n*

Modify > Serial Communications > Serial Port *n* (Serial Port Tab)

Selection	Definition
Baud Rates	Select a baud rate from the options provided.
Data Bits	Select the number of data bits from the options provided.
Parity	Select a parity option of None, Even, or Odd.
Stop Bits	Select the number of stop bits from the options provided.
Flow Control	Select a flow control option of None, XON/XOFF, or ACK/NAK.
Message Format	Select a message format from the drop-down list:

- **Custom Message:** Custom messaging is enabled here if your application uses custom software.
- **Standard Message:** The standard message format begins with a (STX) character and ends with a (CR)(LF).
- **User-Defined Message:** Use the Message Definition form to specify your message format.
- **MUX (ADP) Message:** MUX message format (also known as ADP message format) is for compatibility with other Accu-Sort products.
- **Direct ADP Message:** ADP message format.



NOTE: When DeviceNet or Profibus is installed in an Enhanced Interface Module, the Serial Port screen displays configuration information for that device as well.

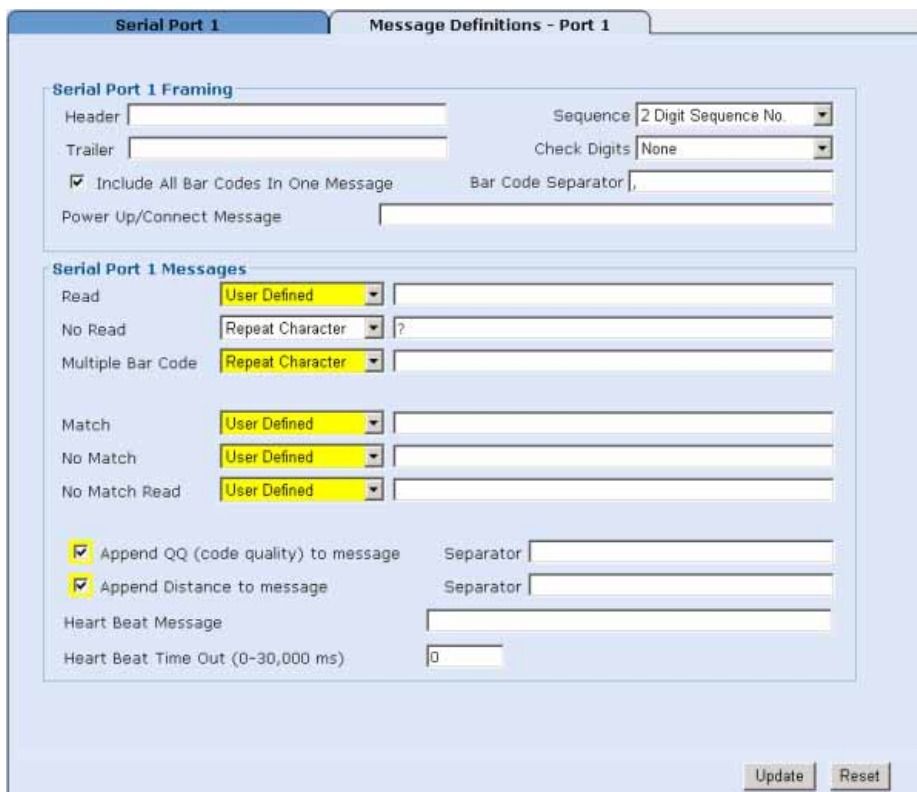

**Modify > Serial Communications > Serial Port n
(Message Definitions Tab)**

Selection	Definition
Serial Port n Framing	Header – Character string specified for the header. Sent at beginning of every message.
	Trailer – Character string specified for the trailer. Use to terminate every message.
	Sequence – Select a sequence specification from the drop-down list. When enabled, a sequence number consisting of the specified number of digits is inserted just after the header.
	Check Digits – Select BCC or CRC from the drop-down list. When enabled, a two-character hexadecimal check character is inserted just prior to the trailer.
	Include All Bar Codes In One Message – Affects how the reader handles multiple bar code transmissions. If enabled, the bar codes are sent in one message (between one header and trailer) and each bar code is separated by the specified “separator.” If disabled, all bar codes are always sent as a complete message (with a header and trailer).
	Bar Code Separator – Enter a string to use to separate multiple bar codes.
	Power Up/Connect Message – Enter a string that will always be sent on reader initialization. Note that for a Network connection, this string is always sent when the socket connection is made.

Serial Port <i>n</i> Messages	Read – Select None , Send Bar Code , or User Defined from the drop-down list.
	<ul style="list-style-type: none"> • None: Nothing is sent for a valid read. • Send Bar Code: The bar code is sent. • User Defined: A user specified message.
	No Read – Select None , Repeat Character , or User Defined from the drop-down list.
	<ul style="list-style-type: none"> • None: Nothing is sent for a no-read • Repeat Character: The specified “repeated character” is sent. • User Defined: A user specified message is sent.
	Multiple Bar Code – Select None , Repeat Character , or User Defined from the drop-down list.
	<ul style="list-style-type: none"> • None: A multiple bar code condition will be reported as a “Read” of the first bar code reported. • Repeat Character: The specified “repeated character” is sent. • User Defined: A user specified message.
	Match - Select None , Send Bar Code , or User Defined from the drop-down list.
	<ul style="list-style-type: none"> • None: If the bar code matches any of the match codes, no message is sent. • Send Bar Code: The bar code is sent. • User Defined: A user specified message is sent.
	No Match – Select None , Repeat Character , or User Defined from the drop-down list.
	<ul style="list-style-type: none"> • None: If the bar code does not match any of the match codes (or was a no-read), no message is sent. • Repeat Character: The specified “repeated character” is sent. • User Defined: A user specified message.
	No Match Read – Select None , Send Bar Code , or User Defined from the drop-down list.
	<ul style="list-style-type: none"> • None: if a valid bar code was read but it does not match any of the match codes, no message is sent. • Send Bar Code: The bar code is sent. • User Defined: A user specified message is sent.
	Append QQ (code quality) to message – When enabled, a two digit “code quality” indication (number from 00 to 99) is appended to the bar code message. The code quality value is separated from the message with the specified separator.
	Append Distance to message – When enabled, the approximate distance to the bar code can be appended to the bar code message. The distance data is separated from the message with the specified separator.

Heart Beat Message – When enabled, if no other message is sent for the time period specified in Heart Beat Time Out, the specified heart beat message string is sent. A time-out of zero (0) disables the heart beat message.

Heart Beat Time Out (0-30,000 ms) – 0 = Disable Heart Beat Message, 1-30,000 = Delay before sending Heart Beat Message

Modify Settings > Network

Selection	Definition
IP Address	An IP address specifies a unique host ID for the reader on a particular TCP/IP network. Consult your network administrator for a valid IP address for the reader.
Net Mask	A netmask modifies a standard IP address into subnets. A default class C net mask should be valid in most cases (either 255.255.255.0 or 255.255.240.0). Consult your network administrator for the net mask value.
Gateway IP Address	A gateway allows the reader to reach other systems not on the local network and remote systems to reach the reader. If the reader requires external connectivity, consult your network administrator for a valid gateway address.
Net Host Port <i>n</i>	Select a connection types from the drop-down list: <ul style="list-style-type: none"> • TCP/IP Server: As a TCP/IP server, a Port # must be specified. In this case it is the TCP/IP client's responsibility to initiate a reader connection. • TCP/IP Client: As a TCP/IP client, aside from the Port #, the Remote IP Address of the TCP/IP server which is to receive the bar code messages must be specified. The Reconnect Time specifies the interval (in seconds) at which the reader attempts to establish a connection. • UDP Messaging: In some instances, it may be desirable to use a connectionless UDP message to send bar code data. In this case, only the Port # and Remote IP Address of the receiver need to be specified.

	<ul style="list-style-type: none"> • EtherNet/IP (Net Host Port 1 only): This enables use of the EtherNet/IP protocol on the reader.
	<p>Message Format – Select one of four message format options from the drop-down list:</p> <ul style="list-style-type: none"> • Custom Message • Standard Message • User Defined Message • MUX (ADP) Message.
Controller /Client Configuration	<p>Number of Client Readers – The number of client readers in a multi-reader network must be defined on the reader acting as the Controller. Select the number of client readers from the drop-down list (up to 14).</p> <hr/> <p>Group Number – All readers in a Controller/Client group (both the Controller and ALL Clients) must be set to the same controller group number. The default of zero (0) disables a reader from listening for messages to become a client.</p> <hr/> <p>Redundant Controller Configuration – Select None, Primary Controller, or Backup Controller from the drop-down list.</p> <ul style="list-style-type: none"> • None: This reader will act only as a client • Primary Controller: This reader will act as the primary controller • Backup Controller: This reader will act as a backup controller if the primary controller fails
Ethernet Link	<p>Select AutoDetect, 100 Mbps/Full Duplex, 100 Mbps/Half Duplex, 10 Mbps/Full Duplex, or 10 Mbps/Half Duplex from the drop-down list.</p>
Controller Multicast IP Address	<p>Enter an IP address for multicast.</p>
Telnet Port	<p>Enter a Telnet port ID.</p>

Modify Settings > Network (Message Definition Tab)

Selection	Definition
Network 1 Framing	Header - Character string specified for the header. Sent at beginning of every message.
	Trailer - Character string specified for the trailer. Use to terminate every message.
	Sequence - When enabled, a sequence number consisting of the specified number of digits is inserted just after the header.
	Check Digits - When enabled, a two-character hexadecimal check character is inserted just prior to the trailer.
	Include All Bar Codes In One Message (checkbox) - Affects how the reader handles multiple bar code transmissions. If enabled, the bar codes are sent in one message (between one header and trailer) and each bar code is separated by the specified "separator." If disabled, all bar codes are always sent as a complete message (with a header and trailer).
	Bar Code Separator - String used to separate multiple bar codes (see above).
	Power Up Message - String that is always sent on reader initialization. Note that for a Network connection, this string is always sent when the socket connection is made.
Network 1 Messages	Read – Select None , Send Bar Code , or User Defined from the drop-down list. <ul style="list-style-type: none"> • None: Nothing is sent for a valid read. • Send Bar Code: The bar code is sent. User Defined: A user specified message.
	No Read – Select None , Repeat Character , or User Defined from the drop-down list.

-
- **None:** Nothing is sent for a no-read
 - **Repeat Character:** The specified “repeated character” is sent.
 - **User Defined:** A user specified message is sent.

Multiple Bar Code – Select **None**, **Repeat Character**, or **User Defined** from the drop-down list.

- **None:** A multiple bar code condition will be reported as a “Read” of the first bar code reported.
- **Repeat Character:** The specified “repeated character” is sent.
- **User Defined:** A user specified message.

Match - Select **None**, **Send Bar Code**, or **User Defined** from the drop-down list.

- **None:** If the bar code matches any of the match codes, no message is sent.
- **Send Bar Code:** The bar code is sent.
- **User Defined:** A user specified message is sent.

No Match – Select **None**, **Repeat Character**, or **User Defined** from the drop-down list.

- **None:** If the bar code does not match any of the match codes (or was a no-read), no message is sent.
- **Repeat Character:** The specified “repeated character” is sent.
- **User Defined:** A user specified message.

No Match Read – Select **None**, **Send Bar Code**, or **User Defined** from the drop-down list.

- **None:** if a valid bar code was read but it does not match any of the match codes, no message is sent.
- **Send Bar Code:** The bar code is sent.
- **User Defined:** A user specified message is sent.

Append QQ (code quality) to message – When enabled, a two digit “code quality” indication (number from 00 to 99) is appended to the bar code message. The code quality value is separated from the message with the specified separator.

Append Distance to message – When enabled, the approximate distance to the bar code can be appended to the bar code message. The distance data is separated from the message with the specified separator.

Heart Beat Message – When enabled, if no other message is sent for the time period specified in Heart Beat Time Out, the specified heart beat message string is sent. A time-out of zero (0) disables the heart beat message.

Heart Beat Time Out (0-30,000 ms) – 0 = Disable Heart Beat Message, 1-30,000 = Delay before sending Heart Beat Message.

Modify Settings > Trigger

There are three options for trigger source:

- Hardware Trigger
- Software Trigger
- Continuous Trigger

Trigger Source = Hardware Trigger

Selection	Definition
Hardware Trigger	Select Active Low or Active High from the drop-down list.

- **Active Low:** The trigger is active when the input signal is low.
- **Active High:** The trigger is active when the input signal is high.

Debounce Duration – Defines the minimum time required for detection of a change in the hardware trigger status.

Trigger Source = Software Trigger

Selection	Definition
Software Trigger	Select a Host n or Net n trigger source from the drop-down list.

**T
r
i
g
g**

The software trigger can be any “host port” either serial or network based.

Start Char – Define the ASCII characters that, when received, will start trigger for the reader.

End Char – Define the ASCII characters that, when received, will end trigger for the reader.

Trigger Source = Continuous Trigger

The image shows three screenshots of the AccuLazr user interface, each representing a different 'Continuous Trigger Type' setting. All screenshots have 'Continuous Trigger' selected in the 'Trigger Source' dropdown.

- Top Screenshot:** 'Continuous Trigger Type' is set to 'Continuous'. There are 'Update' and 'Reset' buttons.
- Middle Screenshot:** 'Continuous Trigger Type' is set to 'Timed'. A 'Trigger Off-Time' field is present with a value of '0' and the unit 'msec'. There are 'Update' and 'Reset' buttons.
- Bottom Screenshot:** 'Continuous Trigger Type' is set to 'Once'. A 'Bar Code Time-Out' field is present with a value of '0' and the unit 'msec'. There are 'Update' and 'Reset' buttons.

Selection	Definition
Continuous Trigger Type	Select a Continuous , Timed , or Once from the drop-down list.
	<ul style="list-style-type: none"> • Continuous: Reader is always in trigger and transmits any bar codes that are seen. • Timed: Whenever a code is transmitted, trigger is removed for the period of time specified in Trigger Off-Time. • Once: Same as continuous, but the same bar code will not be sent a second time until the Bar Code Timeout value has expired.
	<p>Bar Code Time-Out – When Continuous Trigger Type is set to Once, the same bar code will not be sent a second time until the Bar Code Timeout value has expired.</p>

Modify Settings > Relay

I/O 1 Configuration = Used as input

Selection	Definition
Custom Input	Select this for use with applications involving custom software to select a customized input option.
Learn Match Code	When this input is selected, the AL5010 is placed into Test Mode in order to "learn" a match code. When the line is deactivated, Test Mode is exited. When this option is enabled, the last code read is stored in the first entry of the Match Table.
End Trigger	Active as end of trigger signal. NOTE: Available only at I/O#1 if the Trigger Source is set to Hardware Start/End Trigger.
Height Tracking Photoeye	Used for applications that require Height Tracking Photoeyes. Multiple zone photoeyes may be used to divide the reader's depth of field into up to four zones. The Distance from reader (in inches) must also be set.
Active Low/Active High	Select Active Low or Active High from the drop-down list. <ul style="list-style-type: none"> Active Low: The trigger is active when the input signal is low. Active High: The trigger is active when the input signal is high.

If an error message is displayed when saving or retrieving parameters, be sure that the proper dimensions are entered in the Reader Mounting (near/far) and I/O Configuration (distance from scanner).

For installation details, reference the AL5010 Product Manual, Chapter 3, Mounting the Height Tracking Photoeyes.

I/O 1 Configuration = Used as output

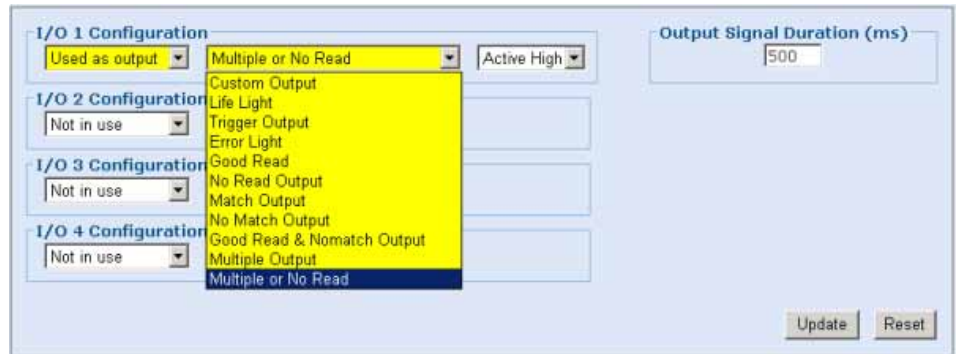

Selection	Definition
Custom Output	Used for applications involving custom software to select a customized output option.
Life Light	Always on while the reader is operating.
Trigger Output	Echoes the status of the trigger signal.
Error Light	Active in the event of an error condition (see later section on errors currently detected).
Good Read Output	Active if all expected codes are read.
No-Read Output	Active if not all expected codes are read.
Match Output	Active if any code matches the match code criteria.
No Match Output	Active if no codes match the match code criteria (includes no-reads).
Good Read and No Match Output	Active if a code was read but did not match the match code criteria.
Multiple Output	Active if too many codes were read.
Multiple or No-Read Output	Active if too many codes were read or a no-read occurred.
Active Low/ Active High	Select Active Low or Active High from the drop-down list. <ul style="list-style-type: none"> • Active Low: The trigger is active when the input signal is low. • Active High: The trigger is active when the input signal is high.
Output Signal Duration (ms)	Enter a duration in milliseconds for the output signal.

Modify Settings > Tracking

Tracking Enabled

Tachometer (Encoder)

Tach Source: Computed Tach

Tach Compute: Start Trigger - End Trigger

Pulse Per Inch: 2.00

Length: 10.0 in.

Reader Mounting

Closest Read Point: 11.5 in.

Farthest Read Point: 37.5 in.

Trigger Reference Point: 0.0 in.

Reader Rotation: 0 deg.

Transmit

Transmit Edge: Trailing Edge

Transmit Point: 20.0 in.

Tracking Configuration

Extend Front: 0.0 in.

Extend Back: 0.0 in.

Tolerance: 0.0 in.

Update
Reset

Tachometer (Encoder) Selections (drop-down list)

Selection	Definition
Hardware/External (Only available with the Enhanced Interface Module)	Used for external hardware tachometer. When this tachometer mode is used, you must also set the number of pulses per inch (PPI) generated by the tachometer.
Constant/Internal	Specify the tach rate to be used (from 25 - 600 ft/min). No external hardware is used.
Computed Tach	There are two options available: Start-End and Start-Start. In both cases, you specify the Length (from 1-200 inches) between either a start and end trigger (Start-End) or between one start trigger and the next (Start-Start). From this information the reader will compute the belt speed and generate an internal tach signal.

Selection	Definition
Reader Mounting	Closest Read Point – Specify the nearest distance from the reader where the reader is expected to read a bar code.
	Farthest Read Point – Specify the furthest distance from the reader where the reader is expected to read a bar code.
	Trigger Reference Point – Specify the distance from the trigger signal to the center point of the scan line.
	Reader Rotation – Specify any rotation of the scan line with respect to the motion of the belt. Set a rotation direction from –180 to 180 degrees.
Transmit	Transmit Edge – Specifies which edge of the package (leading or trailing) is used to reference the transmit point.
	Transmit Point – The point at which bar code data is transmitted. Defines the number of inches after the specified edge of the package passes the trigger before data transmission occurs.
Tracking Configuration	Extend Front (in.) – Use to increase the virtual size of the package by increasing the leading edge (front) of the package.
	Extend Back (in.) – Use to increase the virtual size of the package by increasing the trailing edge (back) of the package.
	Tolerance – Specify the tolerance (in inches) for associating a label with a box.

Modify Settings > FAST Monitor™

Select the Reader Position from the drop-down menu. Reference the illustration for relative positions.

IMPORTANT: Be sure to use a unique position that relates to the reader's location in the scanning tunnel.

FAST Monitor Port
 Port No. Reconnect Time Remote IP Addr. . . .

NOTE: Connection parameters are only applicable for controllers and standalone units

Update Reset



NOTE: For more information on FAST Monitor functionality, see the FAST Monitor Product CD, online help or contact us at 1-800-BAR-CODE.

Selection	Definition
Tunnel Information	Tunnel Name – Assign a name for the tunnel/array.
	Reader Position – Select the Reader Position from the drop-down menu. Reference the illustration for relative positions.
FAST Monitor Port	Port No. – If the reader is a standalone unit or controller in a scanning tunnel, set the FAST Monitor Port information. The port number is always 9899.
	Reconnect Time – Enter a reconnect time for this port.
	Remote IP Addr. – Enter the IP Address for the FAST Monitor Server.

Modify Settings > Advanced

Data Filtering			
Scan Filtering (Skip Scan)	<input type="text" value="0"/>	Minimum Transitions	<input type="text" value="6"/>
Laser 1 DOF: Near Dist (in)	<input type="text" value="10.0"/>	Far Dist (in)	<input type="text" value="45.0"/>
Laser 2 DOF: Near Dist (in)	<input type="text" value="20.0"/>	Far Dist (in)	<input type="text" value="42.0"/>
Bar Code Size			
Scan Rate	<input type="text" value="1000"/>	Field of View	<input type="text" value="54"/>
Min Narrow Element (mils)	<input type="text" value="10"/>	Max Narrow Element (mils)	<input type="text" value="20"/>
Maximum Tilt	<input type="text" value="45"/>		
DRX Setting			
<input checked="" type="checkbox"/> DRX Enabled			
Overlay Ratio	<input type="text" value="65"/>	Radio M Factor	<input type="text" value="14"/>
Win.	<input type="text" value="4"/>	Max Recurse	<input type="text" value="1"/>
Pairs	<input type="text" value="4"/>	Kill Limit	<input type="text" value="5"/>
Change	<input type="text" value="600"/>	Overlay	<input type="text" value="2"/>
Search (0.0-3.0)	<input type="text" value="0.50"/>	<input checked="" type="checkbox"/> Overlay Recover Enabled	
		<input type="button" value="Default DRX"/>	
Transmit QQ			
Minimum QQ	<input type="text" value="3"/>	Maximum QQ	<input type="text" value="200"/>
		<input type="button" value="Update"/> <input type="button" value="Reset"/>	



CAUTION: Changing the Advanced settings can adversely affect reader performance. These settings are to be modified only under the guidance of Accu-Sort Technical Support.

Selection	Definition
Data Filtering	Scan Filtering (Skip Scan) –
	Laser <i>n</i> DOF: Near/Far Dist (in) – Enter near and far distance depth of field for the laser.
	Minimum Transitions – Enter the minimum transitions allowed.
Bar Code Size	Scan Rate – Displays the scan rate.
	Field of View – Displays the filed of view.
	Min Narrow Element (mils) – Enter the minimum width of the barcode’s narrowest element in thousandths of an inch.
	Max Narrow Element (mils) – Enter the maximum width of the barcode’s narrowest element in thousandths of an inch.
	Maximum Tilt – Enter the maximum bar code tilt.
DRX Setting	DRX Enabled – Select to enable DRX
	 NOTE: The DRX settings typically will not need to be modified. Contact Accu-Sort Support for details (1-800-BAR-CODE).
Transmit QQ	Minimum QQ – Enter the smallest allowable QQ value for a code to be transmitted.
	Maximum QQ – Enter the maximum QQ value. This forces the transmission of a code after the maximum QQ value is reached.

Modify Settings > Raster

Raster Scanline

Upper Sweep (-20 to +20 degrees)

Lower Sweep (-20 to +20 degrees)

Oscillating Frequency (Hz)

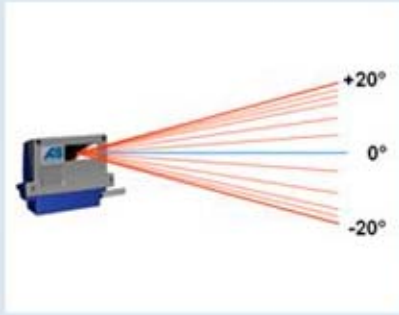
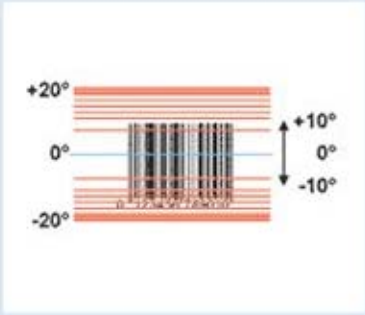





NOTE: The **Modify Settings > Raster** selection is only available on the menu tree when an AL5010 unit with the raster option.

Selection	Definition
Upper Sweep	Specify the upper limit of the laser from -20-degrees to +20 degrees from 0-degrees.
Lower Sweep	Specify the lower limit of the laser from -20-degrees to +20 degrees from 0-degrees.
	<div style="display: flex; align-items: center;"> <p>NOTE: The laser will sweep between the specified upper and lower values. Example 1: If the upper value is set at -5-degrees and the lower value is set at -10-degrees, the laser will sweep the 5-degree range specified below 0-degrees. Example 2: If both the upper and lower values are set at the same value, the laser will stay on that fixed value without sweeping.</p> </div>
Oscillating Frequency (Hz)	Specify the frequency at which the vibrating vane (mirror) will oscillate between 0 and 10 Hz. This is the speed of the mirror oscillation with 0 being effectively stopped and 10 oscillating the fastest.

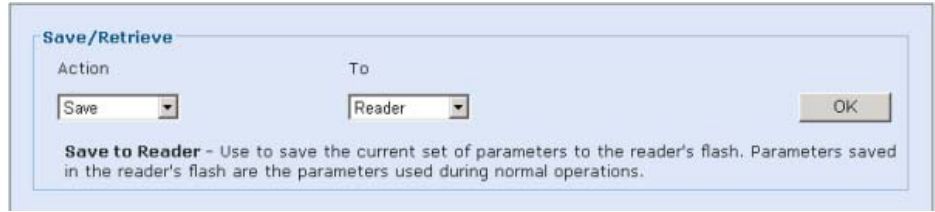
Save / Retrieve



Selection	Definition
Save / Retrieve: Action = Save	To – Select File , Reader , or Base from the drop-down list. <ul style="list-style-type: none"> • File: Use to specify a file name and location to store the current parameter settings on your computer. • Reader: Use to save the current set of parameters to the reader. Parameters saved in the reader are the parameters used during normal operations. • Base: Use to save the current set of parameters to the mounting base as a backup copy.

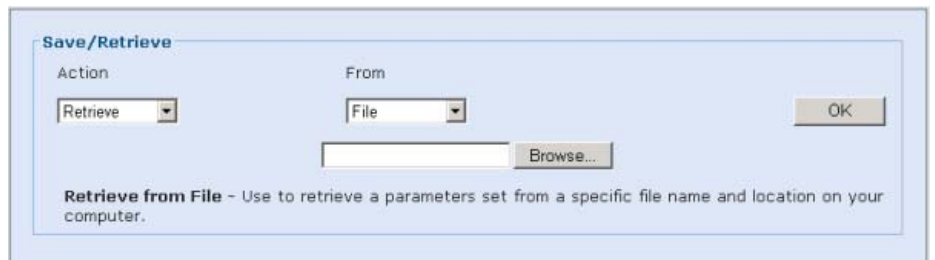

Selection	Definition
Save / Retrieve: Action = Retrieve	From – Select File or Base from the drop-down list. <ul style="list-style-type: none"> • File: Use to retrieve a parameters set from a specific file name and location on your computer. • Base: Use to retrieve the parameters stored in the reader's mounting base. This is especially useful when it becomes necessary to load the correct parameters to a replacement reader module.



Selection	Definition
Save / Retrieve: Action = Default	Use to return the reader's parameters to the hard-coded "default" values built into the reader software.

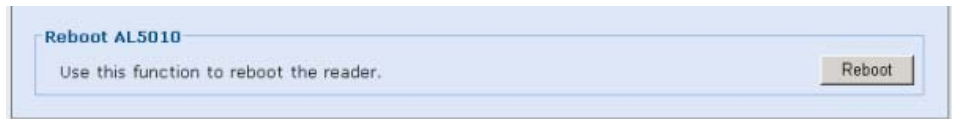

Selection	Definition
Reboot AL5010	Click to reboot the bar code scanner.

Diagnostics

Comprehensive diagnostic are available that enable you to monitor:

- Status LEDs
- Read Quality
- Messages
- Box Information
- Message Monitor
- Read Rate Log
- Counters Log
- Message Log
- Upload Firmware

For additional information, click the  button

Diagnostics

The Diagnostics main page describes the items available in its menu tree.

Diagnostics > Monitor

The screenshot displays the 'Monitor' interface with the following sections:

- Status LEDs:** A grid of 10 LEDs with labels: Status (Green), Trigger (Black), Good/No Read (Black), Multiple codes (Black), Match (Black), Network (Black), I/O 1 (Red), I/O 2 (Black), I/O 3 (Black), and I/O 4 (Black).
- Read Quality:** A bar chart for Read Rate (73), Scans/Code (26), Code Postion (2619), and Code Quality (QQ). It also shows Laser 1 (0) and Laser 2 (10).
- Messages:** A list of messages including bar code numbers and quality metrics, with '<NOREAD>' entries.
- Box Information:** A table showing Belt Speed (fpm), Belt Length (in.), Code Postion (in.), and Scans/Trigger.
- Message Monitor:** A scrollable log of hexadecimal data.
- Controls:** 'Start' and 'Stop' buttons, a port selection menu (None, Serial Port 1, Serial Port 2, Net Port 1, Net Port 2), and a 'Start Test Mode' button.



NOTE: The Monitor is a Java application and requires Java and the appropriate browser plugin.

Selection Status LEDs

Definition

Status – **GREEN** to indicate the overall "health" of the reader. (If **RED**, troubleshooting is required.)

Trigger – **GREEN** indicates the trigger input. The LED is activated upon trigger input regardless of trigger source (including software trigger).

Good/No Read – **GREEN** indicates a good (valid) bar code has been decoded. **RED** indicates a no-read (or incomplete decode).

Multiple codes – **RED** indicates more codes than desired were read.

Match – **GREEN** indicates a code matches the Match Code criteria.

Network – **GREEN** indicates a network host connection has been made. **RED** indicates a problem with the reader network.

- **Example:** A red Network LED upon power up could indicate the MAC address was not set at the factory.

Network (multi-reader networks only) – **GREEN** indicates a valid connection to a Controller or Client. Flashing **RED** on a

	<p>Controller indicates a problem with a Client connection. RED indicates a Controller with incompatible settings tried to initiate a Client connection.</p>
	<p>I/O 1 through I/O 4 – Indicates the status of the programmable relay I/O lines.</p>
Read Performance	<p>Read Quality – Graph 0-100) The large percentage bar maps to the values displayed on the reader bar graph. The graph is a dynamic measure of "how well" the bar code was read.</p> <p>Scans/Code – Indicates how many passes of the laser (scan lines) contributed to the reading of the code.</p> <p>Code Position – Indicates the bar code's position in the reader's scan line (from zero to 4095).</p> <p>Code Quality (QQ) – Laser 1 / Laser 2 - Indicates the QQ (code quality) value for each laser that read the bar code.</p>
Messages	<p>Diagnostic messages from the reader are displayed here. This is primarily information on each bar code read.</p> <p>Use the buttons below the Messages area to start and stop (freeze) the messages being displayed for better diagnostics.</p> <p>To copy text, highlight the text and then perform a copy function. Paste the text into an external text program.</p>
Box Information	<p>Belt Speed (FPM) – Displays the belt speed in feet per minute.</p> <p>Box Length (inch) – Displays the box length in inches.</p> <p>The box length is influenced by the extend front or extend back option in the Tracking screen.</p> <p>Example: If the extend front is set to 2 and a 10 inch box is sent through the system, then the Box Length is reported as 12 inches</p> <p>Code Position (inch) – Displays the code position on the box in inches.</p> <p>Scans/Trigger – Displays the number of scans per trigger cycle.</p> <p>Distance (in) – Displays the approximate distance from the scanner to the bar code in inches.</p>
Message Monitor	<p>Use the Message Monitor to view the messages being sent from any of the reader host ports (either serial or network).</p> <p>Select the communication port you want to monitor from the option group below the message monitor.</p>

Start Test Mode

Click **Start Test Mode** to put the scanner in timed test mode. The scanner will then read any readable bar code place in its beam.

Diagnostics > Log Viewer

AL5010 Log Viewer

DISPENET=18
 Link: Active (100Mbps-Full Duplex)
 MAC Address: 00:0e:13:03:00:1b

Ethernet MAC Stats

Tx Octets:	10875897	RX Octets:	11543748
Net Octets:	39452099		

Ethernet MAC Errors

Rx Align Errors:	0	RX CRC Errors:	0
Rx Undersized Errors:	0	RX Oversized Frames:	0
Rx Jabber Count:	0	RX No Net Buffers:	573637812
Rx SOF Overrun Errors:	0	RX Fragments:	0
Rx MOF Overrun Count:	0	RX DMA Overruns:	0
Tx Carrier Losses:	0	Tx Collisions:	0
Tx Single Coll Errors:	0	TX Mult Coll:	0
Tx Excessive Coll:	0	TX Late Collisions:	0
Tx Underrun Errors:	0		

Read Rate Counters Message Log Clear

Command

DISP ENET Send Command

Use this field to enter and send commands (example: DISP ENET)

Use this screen to review the performance logs saved by the reader. The three most commonly viewed logs are available by selecting one of the three buttons:

- Read Rate
- System Counters
- Message Log

You can also enter a log request in the **Command** field.

Diagnostics > Update Firmware

Use **Update Firmware** to reload the reader firmware.

CAUTION: This function should only be performed under the guidance of Accu-Sort Technical Support.

To Extract Image

1. Click Extract Image
2. In Save as window, save the image (*.as) files to your computer. The graphic on-screen indicates Extract Image is in-process.
3. A message will appear when Extract Image is complete.

To Burn Flash

1. Click Browse button.
2. In Open window, open an image file (*.as) to burn to flash. Click Burn Flash button. The graphic on-screen indicates Burn Flash is in-process.
3. A message will appear when Burn Flash is complete.
4. Reboot (cycle power) AL5010.

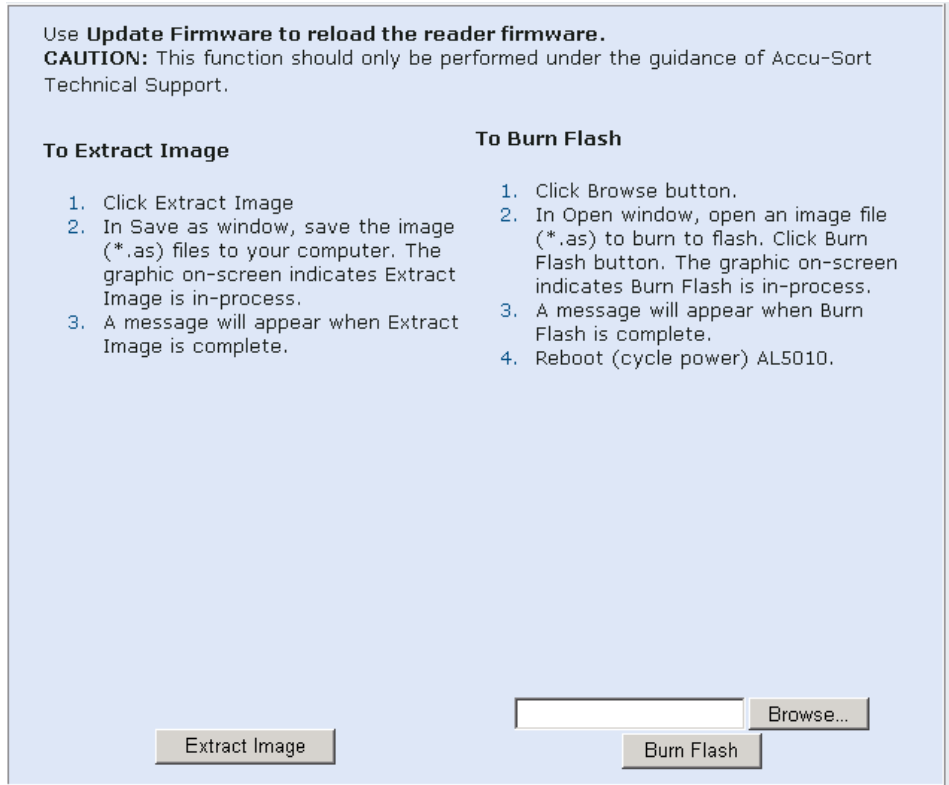

Use **Update Firmware** to reload the reader firmware.



CAUTION: This function should only be performed under the guidance of Accu-Sort Technical Support.

Notes:

AL5010 Networking Guide

Introduction

The AL5010 bar code reader includes a built-in Ethernet interface that can be used both for receiving bar code data from the AL5010 as well as monitoring and configuring the AL5010.

AL5010 Ethernet Hardware Configuration

The AL5010 Ethernet hardware supports a 10/100mbps full or half-duplex Ethernet link. (Wiring information is provided in *Chapter 4* and *Appendix F*.)

Use the AccuLazr User Interface Log Viewer's **DISP ENET** command to monitor for Ethernet errors.

The AL5010 hardware will detect the swapping of the Transmit and Receive lines and configure appropriately. This allows a straight cable to be used to connect two AL5010s.

AL5010 Network Software Configuration

The AL5010 browser-based user interface makes it possible to connect to the AL5010 over the network.

Currently, the AL5010 only supports static IP addresses. The defaults for the AL5010 network settings are listed below:

Parameter	Default Value
IP Address	192.168.3.100
Net Mask	255.255.255.0
Gateway	0.0.0.0

If you are adding your AL5010 to a larger network, you must obtain an IP addresses (as well as the other parameters) from your network administrator. If the AL5010s are to operate on a closed network, you may assign your own IP addresses. This is typically by just incrementing the last number from the default (192.168.3.101, 192.168.3.102, etc.).

Controller/Client Communications

Up to fourteen (14) AL5010s can be configured to operate together as a single unit. All communications between readers is accomplished over an Ethernet network.

In this configuration, one AL5010 must be set up as a Controller. The Controller initiates connections with the remaining readers, configuring them to operate as Clients. The trigger input (such as a photoeye) is only connected to the Controller.

Setting up AL5010s for a Multi-Reader Network

Wiring

If only two readers are to be communicating, and the Ethernet network is not needed for diagnostics or host communications, the readers can be connected directly with a CAT6 network cable. However, it is recommended to use a network switch when connecting any combination of scanners, so that diagnostics can be performed while the system is running.

Tachometer and trigger are connected to the controller AL5010. The controller AL5010 transmits speed and trigger messages to the Clients over the network.

Configuration

1. All readers should be operating on the network with unique IP addresses.
2. All AL5010s that are to communicate together should be assigned the same **Group Number**. A Group Number of zero (which is the default) disables the Controller/Client capability.
3. The **Number of Client Readers** should be changed from zero on the Controller in order to identify this unit as the Controller. After being configured as a Controller, it will broadcast messages onto the network to discover the specified number of Clients.

The screenshot shows the 'Modify > Network' configuration window. The 'Network Settings' tab is active. The 'Controller / Client Configuration' section is circled in red. It contains the following fields:

- No. of Client Readers:** A dropdown menu set to 0.
- Group No:** A text input field set to 0.
- Redundant Controller Configuration:** A dropdown menu set to None.
- Primary Head Number:** A text input field set to 0.
- Backup Head Number:** A text input field set to 0.

Below these fields is a note: "Any reader can be configured to initiate a network connection with a number of client readers. All readers, both controller and client(s), must be set to the same (non-zero) group number."

When using Controller/Client configuration, the client **Tach Source** must be set to **Constant/Internal**. The Clients will rely on a speed message sent from the Controller eliminating the need to provide a tachometer input to the clients.

In an AL5010 multi-reader network, bar codes are sent from the clients to the controller as soon as they are read. The Controller AL5010 is responsible for transmitting the bar code data to the host.

Restrictions

- If a controller is configured with tracking enabled, all clients must also have tracking enabled.
- All units must have the same bar code types enabled, in the same order.
- Clients do not transmit data messages through their serial or network host ports.

Multi-Reader Network LED and Troubleshooting

The main AL5010 diagnosis tool is the Network LED. An AL5010 controller will FLASH the LED red once a second if it cannot locate the specified number of Clients. When all connections are made, the Network LED becomes a solid green.

For a client, the Network LED remains off until a Controller initiates a connection. Once a connection is made, the LED becomes a solid green.

Network Administrator Information

All communications from a Controller to the Clients is done using TCP/IP Multicasting. The default multicast IP address used is 239.255.0.x, where x is called the Controller Group Number (value from 0 to 255). If multiple Controller/Client Groups are on the same network, it is important that they be assigned unique group numbers so that each group is using a unique Multicast IP address.

It is important that the network be configured so that Multicast network traffic will be transmitted between these readers. The AL5010 multicast messages are configured with a Time-To-Live of 1, so they will not pass through a router. Additionally, an Ethernet Switch which supports IGMP snooping may be utilized to restrict the multi-cast traffic seen by the AL5010s as well as any other items on the same network.

All communications from the Clients back to the Controller uses standard UDP messaging.

Network Host Communications

The AL5010 provides a number of options for transmitted bar code to another computer (typically referred to as the "host"). Additionally, two host network connections are supported each with different message definition and formatting. These connections use ports 3001 and 3002 by default, but these values are modifiable.

TCP/IP Server

Operation as a TCP/IP server is the default configuration for the AL5010. In this case, for an application to communicate with an AL5010 from a "host computer", the application should just initiate a simple TCP/IP socket connection. When a socket connection to the AL5010 is established, the green AL5010 network LED will be illuminated (unless client/controller mode is in use in which the LED indicates the status of the inter-AL5010 network connections).

One issue should be considered when designing such an application: As with any socket connection, if one side or the other terminates the connection without properly closing it - the connection can be left open.

For example, if a host computer has initiated a connection to an AL5010 and the host computer "crashes" - the connection on the AL5010 will remain open until the AL5010 attempts to send the next message (normally the next bar code). At this point, the AL5010 will detect the connection from the host computer has been terminated and clear the connection allowing the host computer to reconnect.

However, it is possible that the AL5010 might be powered off while a host connection is active (or if the power is cycled on an intermediate piece of network equipment such as a hub or a switch). In this case, the AL5010 socket connection will be closed but the host computer may not be aware of this change. To handle this situation, it may be desirable to implement a means by which the host computer can test the state of the network connection.

One option is to periodically send a simple message (e.g., just a null character or just a single STX character) to the AL5010 verifying the link is still active.

Another option is for a heartbeat message to be enabled on the AL5010. This both provides the host computer with a means for determining if the link has been lost (by lost of the heartbeat) and provides the AL5010 with quicker determination of lost of communications with the host computer. This is the recommended approach.

TCP/IP Client

It is also possible to configure the AL5010 to operate as a TCP/IP Client. In this case, you must also specify the IP address of the computer to which the AL5010 is to attempt to initiate a connection. If a connection cannot be established, the AL5010 will reattempt the connection after the specified number of seconds (default is 5 seconds).

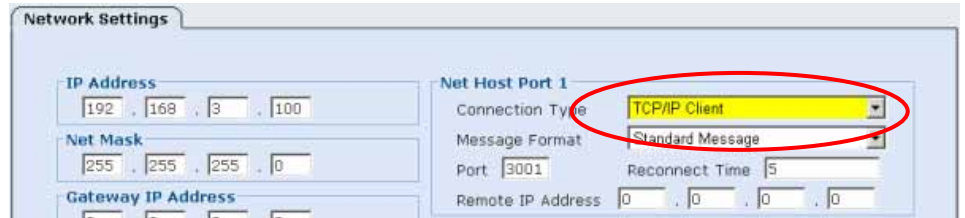

Similar issues exist regarding improper closing of connections as described in the TCP/IP Server section. As a result, it is also recommended that a heartbeat message be enabled for TCP/IP Client connections.

UDP Messaging

For UDP messaging, only the destination IP address and port need to be specified. Since this is a connectionless means of transfer, there are no issues with checking for loss of connection.

EtherNet/IP

The AL5010 supports the EtherNet/IP™ Industrial Networking protocol. EtherNet/IP™ simplifies the communication of bar code and input/output data with other EtherNet/IP enabled devices, such as a programmable controller.

EtherNet/IP is not enabled by default on the AL5010. To enable, select EtherNet/IP as the **Connect Type** for Net Host Port 1 on the Network Settings page of the user interface. When EtherNet/IP is enabled, all of the other network capabilities of the AL5010 remain active. For example, an AL5010 controller can be configured for EtherNet/IP communications with a programmable controller while still communication with one or more AL5010 clients.

Once enabled, EtherNet/IP allows the AL5010 to communicate with other EtherNet/IP enabled devices. This can be done using:

- **Explicit Messaging**,
- **I/O Messaging**, and
- **On-Demand Messaging** (a special AL5010 protocol for ControlLogix Controllers only)

All of the AL5010 **EtherNet/IP Object definitions** are defined later in this appendix. Refer to this appendix when setting up the interface to your device.

Explicit Messaging is used when a peer-to-peer network is needed for communication. For example: In order to read parameters from the AL5010, a PLC (Programmable Logic Controller) must issue a Peer-To-Peer Read command to the AL5010. In order to write parameters to the AL5010, the PLC must issue a Peer-To-Peer Write Command to the AL5010.

I/O messaging can be used to monitor and set AL5010 I/O bits as well as to obtain bar code data from the AL5010. The disadvantage is the I/O messages are always sent at scheduled intervals creating a lot of network traffic.

On-Demand Messaging only works with ControlLogix Controllers. This option uses standard EtherNet/IP messaging, but allows bar code data to be sent to the Controller only when a bar code is read. It can be used in conjunction with I/O messaging.

EtherNet/IP Options

When EtherNet/IP is enabled, a new tab become available within AccuLazr user interface that allow you to configure some additional options.

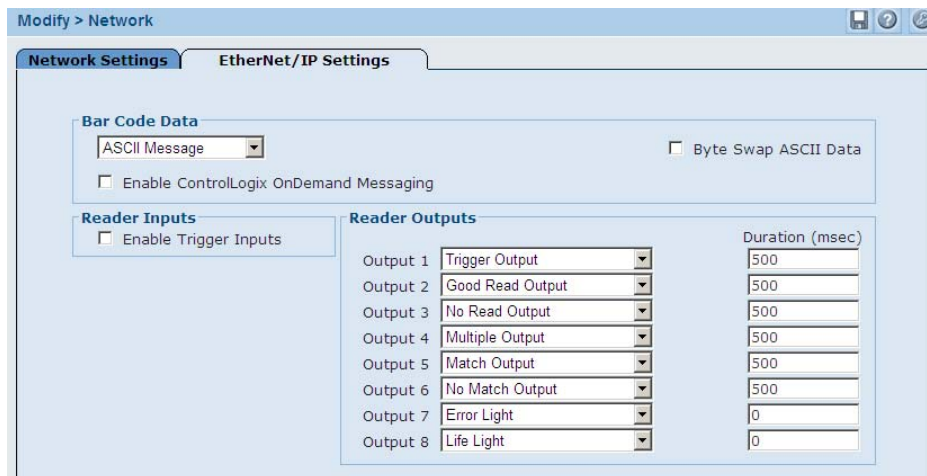

These parameters are described in more detail earlier in this manual, but a quick overview provides some context here. (See *Chapter 5*.)

The **Bar Code Data** parameters allow you to manipulate the format of the bar code data. Most notable if your bar codes only contain numeric digits, you can configure the AL5010 to convert the bar codes to a numeric value instead of transmitting them as ASCII text.

Additionally, you can enable the On-Demand Messaging Option for ControlLogix Processors. This is described in more detail later in this document.

If the EtherNet/IP **Trigger Input** is enabled, the AL5010 Trigger settings are ignored and the AL5010 is triggered solely by manipulating the Trigger Bit in the Output Word (contained in the AL5010 Assembly and Output Objects).

The AL5010 Outputs function the same as AL5010 relay outputs, but they manipulate bits within the AL5010 Input Word (contained in the AL5010 Assembly and Input Objects).

The AL5010 can relinquish control of the internal AL5010 relays to another EtherNet/IP device. When this has been done, these relays are controlled by bits within the Output Word.

Explicit Messaging Example

Used for communication between AL5010 and a Programmable Logic Controller (PLC).

Contact Accu-Sort support at 1-800-BAR-CODE (1-800-227-2633) for help with your specific application.

I/O Messaging Example

The following example illustrates how an AL5010 can be configured to communicate with a ControlLogix processor using I/O messaging. Utilizing this information along with the AL5010 Object definitions (on page B-19), it should be possible to adapt these directions for other EtherNet/IP devices.

When EtherNet/IP is enabled on the AL5010, EtherNet/IP I/O Messaging is automatically enabled. No further configuration is needed to setup I/O messaging.

Since the ControlLogix processor will treat the AL5010 as an I/O device, to setup an EtherNet/IP I/O message transfer between an AL5010 and a ControlLogix processor, you need to configure your AL5010 as a Generic Ethernet Module in the ControlLogix RSLogix 5000 interface I/O tree.

To add a module:

1. Under the I/O Configuration Tree, right-click on the entry for your Ethernet module (e.g., 1756-ENET/A) and select New Module.
2. You will be presented with a list of options similar to what is shown below. From this list select ETHERNET-MODULE for the Generic Ethernet Module.
3. Specify the **Module Properties** for your AL5010.
 - a. The most important step is that you must first set the **Comm Format** to Data-INT. This must be done first since it cannot be changed later.
 - b. After this you can specify the **Name**, **Description** and **IP Address** of the AL5010.
4. The Connection Parameters must be specified as follows:

	Assembly Instance	Size
Input	100	68
Output	112	2
Configuration	128	0

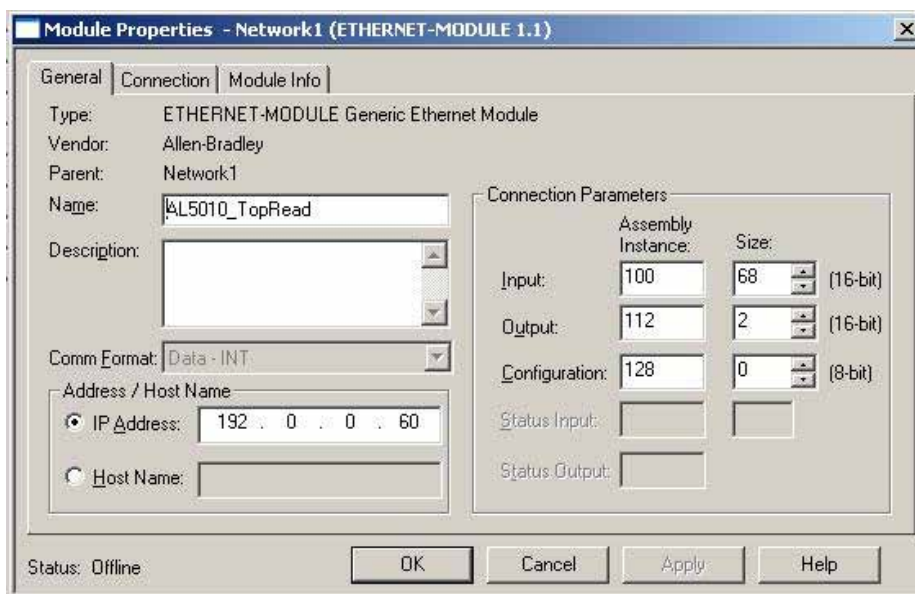



NOTE: You can only “schedule” I/O message transfers to the AL5010 at a fixed interval. The **Connection Tab** allows you to specify this interval. The AL5010 will handle intervals down to 10 milliseconds. However, intervals this small may affect the overall AL5010 performance.

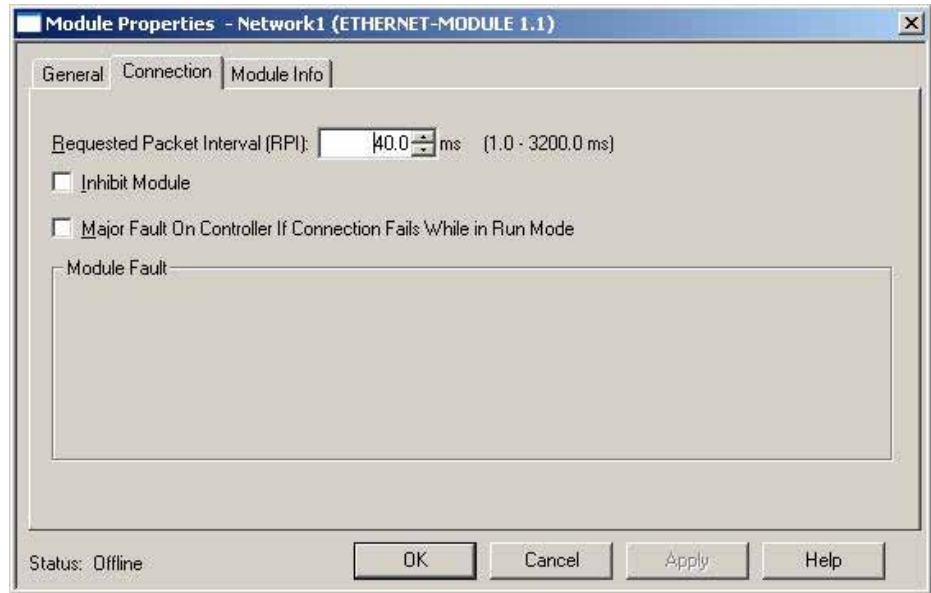

After this module definition for the AL5010 has been completed, tags will be created in the controller based on the name you specified for this AL5010 on the properties page for the module. These tags will consist of the name followed either by the letter ‘C’ (Configuration), the letter ‘O’ (Outputs) or the letter ‘I’ (Inputs). These tags are based on the AL5010 assembly objects.

AL5010:C Configuration Data

This data is not used.

AL5010:I Input Data

Tag Name	Value	Description
AL5010:I.Data[0]	Discrete Input Word	See bit definitions.
AL5010:I.Data[1]	Bar Code Sequence Number	This field is updated every time the bar code data is updated. However, the bar code data will only be updated when the "Last Bar Code Sequence Number" (see Output Data) is set equal to this value.
AL5010:I.Data[2]	Bar Code Status	Not currently used.
AL5010:I.Data[3]	Bar Code Size (words)	Number of words which contain the bar code data
AL5010:I.Data[4-67]	Bar Code Data	
Discrete Input Word		
Bit		
0	AL5010 Programmable Output #1	
1	AL5010 Programmable Output #2	
2	AL5010 Programmable Output #3	
3	AL5010 Programmable Output #4	
4	AL5010 Programmable Output #5	
5	AL5010 Programmable Output #6	
6	AL5010 Programmable Output #7	
7	AL5010 Programmable Output #8	
8-15	Unused	

AL5010:O Output Data

Tag Name	Value	Description
AL5010:O.Data[0]	Discrete Output Word	See bit definitions.
AL5010:O.Data[1]	Last Bar code Sequence Number Received	This field must be updated to match the Bar Code Sequence Number each time the bar code data has been processed.
Discrete Output Word		
Bit	Bit = 0	Bit = 1
0*	Trigger Off	Trigger On
1 – 7	Unused	Unused
8*	AL5010 Relay #1 Off	AL5010 Relay #1 On
9*	AL5010 Relay #2 Off	AL5010 Relay #2 On
10*	AL5010 Relay #3 Off	AL5010 Relay #3 On
11*	AL5010 Relay #4 Off	AL5010 Relay #4 On
12-15	Unused	Unused
* If enabled on AL5010		

On-Demand Messaging (ControlLogix)

On-Demand messaging provides another option for transferring bar code data to your ControlLogix processor. With on-demand messaging, the data transfer occurs as soon as the bar code data is available, not as the result of constant messaging at a schedule interval.

Typically, On-Demand messaging is used in conjunction with I/O messaging. For applications requiring only the transfer of bar code data, using On-Demand Messaging allows the I/O packet interval to be increased (just to provide a heartbeat with the AL5010) reducing overall network utilization.

On-Demand messaging can be enabled on the AL5010 from the EtherNet/IP tab on the network page within the user interface. When enabled, you need to specify the IP address and slot for the ControlLogix processor, along with the name of the Tag to contain the bar code data.

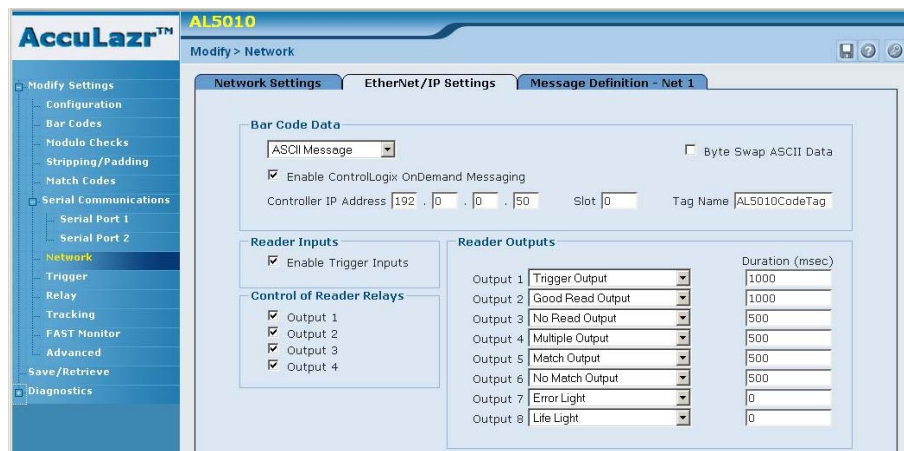

Once this is complete, you need to define a new Tag on the ControlLogix using its RSLogix 5000 interface. The new tag should have a type of INT and a dimension of 67 words. The name must match the name specified on the AL5010.

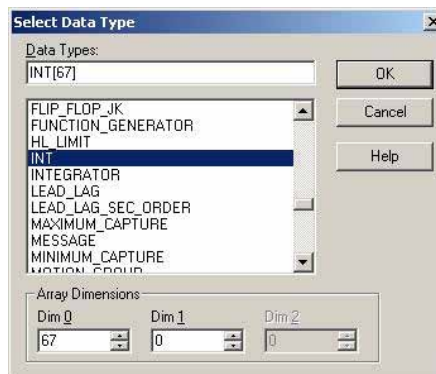

These tags will be updated every time a bar code is read. The following table defines the format of the data within this tag.

On-Demand Tag

Tag Name	Value	Description
AL5010Tag.Data[0]	Bar Code Sequence Number	This field is updated every time the bar code data is updated. However, the bar code data will only be updated when the "Last Bar Code Sequence Number" (see Output Data) is set equal to this value.
AL5010Tag.Data[1]	Bar Code Status	Not currently used.
AL5010Tag.Data[2]	Bar Code Size (words)	Number of words which contain the bar code data
AL5010Tag.Data[3-66]	Bar Code Data	

EtherNet/IP Object Models

Glossary

This is a description of the different data types that are used in the documentation of the object model. These are standard definitions of the Open DeviceNet Vendor Association (ODVA). For additional information, visit their web site: <http://www.odva.org/>.

Summary of Objects

The following standard objects are supported. More details than provided in this appendix can be found in the EtherNet/IP™ Specification available from the Open DeviceNet Vendors Association (ODVA).

- Identity Object (01_{HEX})
- Message Router Object (02_{HEX})
- Assembly Object (04_{HEX})
- Connection Manager Object (06_{HEX})
- TCP Object (F5_{HEX})
- Ethernet Link Object (F6_{HEX})

The following Vendor Specific Objects have been defined to support the AL5010 Bar Code Reader.

- Bar code Data Object (70_{HEX})
- Discrete Input Data Object (71_{HEX})
- Discrete Output Data Object (72_{HEX})

Definitions

The following table has a description of all of the data types used.

USINT	Unsigned Short Integer (8-bit)
UINT	Unsigned Integer (16-bit)
UDINT	Unsigned Double Integer (32-bit)
STRING	Character String (1 byte per character)
BYTE	Bit String (8-bits)
WORD	Bit String (16-bits)
DWORD	Bit String (32-bits)

Standard Objects

Identity Object (01_{HEX} - 1 Instance)

Class Attributes				
Attribute ID	Name	Data Type	Data Value	Access Rule
1	Revision	UINT	1	Get
Instance Attributes				
Attribute ID	Name	Data Type	Data Value	Access Rule
1	Vendor Number	UINT	25 _{DEC}	Get
2	Device Type 0x00 – Generic	UINT	00 _{HEX}	Get
3	Product Code Number	UINT	01	Get
4	Product Major Revision Product Minor Revision	USINT USINT	03 01	Get
5	Status Word (see below for definition)	WORD	See Below	Get
6	Product Serial Number	UDINT	Unique 32 Bit Value	Get
7	Product Name Structure of: Product Name Size Product Name String	UINT USINT[0-32]	15 "Bar Code Reader"	Get
Status Word				
Bit	Bit = 0	Bit = 1		
0	No I/O Connection	I/O Connection Allocated		
1 – 15	Unused	Unused		
Common Services				
Service Code	Implemented for		Service Name	
	Class Level	Instance Level		
0E _{HEX}	Yes	Yes	Get_Attribute_Single	
05 _{HEX}	No	Yes	Reset	
Reset Service Code				
Service Code	Class	Instance	Attribute	Description
05 _{HEX}	1	1	0	Force software reset
05 _{HEX}	1	1	1	Reload factory settings and reset

Message Router Object (02_{HEX})

This object has no supported attributes.

Assembly Object (04_{HEX} – 4 Instances)

Class Attributes				
Attribute ID	Name	Data Type	Data Value	Access Rule
1	Revision	UINT	1	Get
2	Max Instance	UINT	81	Get
Instance 0x64 Attributes (Input Instance 1)				
Attribute ID	Name	Data Type	Default Data Value	Access Rule
3	Input Data Structure of: Discrete Input Word (see below) Bar code Sequence Number Bar code Status (reserved) Bar code Size Word Bar code Data [UINT]	UINT UINT UINT UINT UINT [] varies (up to 64)	0 0 0 0 0	Get
Discrete Input Word				
Bit				
0	AL5010 Programmable Output #1			
1	AL5010 Programmable Output #2			
2	AL5010 Programmable Output #3			
3	AL5010 Programmable Output #4			
4	AL5010 Programmable Output #5			
5	AL5010 Programmable Output #6			
6	AL5010 Programmable Output #7			
7	AL5010 Programmable Output #8			
8-15	Unused			
Instance 0x70 Attributes (Output Instance 1)				
Attribute ID	Name	Data Type	Default Data Value	Access Rule
3	Output Data Structure of: Discrete Output Word (see below) Last Bar code Seq. Num Received	UINT UINT	0 0	Get / Set
Discrete Output Word				
Bit	Bit = 0	Bit = 1		
0*	Trigger Off	Trigger On		
1 – 7	Unused	Unused		
8*	AL5010 Relay #1 Off	AL5010 Relay #1 On		
9*	AL5010 Relay #2 Off	AL5010 Relay #2 On		
10*	AL5010 Relay #3 Off	AL5010 Relay #3 On		
11*	AL5010 Relay #4 Off	AL5010 Relay #4 On		
12-15	Unused	Unused		
* If enabled on AL5010				
Instance 0x80 Attributes (Configuration Instance)				
Most I/O clients include a Configuration path when opening an I/O connection to a server. There is no Configuration data needed.				
Instance 0x81 Attributes (Heartbeat Instance – Input Only)				
This instance allows clients to monitor input data without providing output data.				
Common Services				
Service Code	Implemented for		Service Name	
	Class Level	Instance Level		
0E _{HEX}	Yes	Yes	Get_Attribute_Single	
10 _{HEX}	No	Yes	Set_Attribute_Single	

Connection Manager Object (06 HEX)

This object has no attributes.

TCP Object (F5_{HEX} - 1 Instance)

Class Attributes				
Attribute ID	Name	Data Type	Data Value	Access Rule
1	Revision	UINT	1	Get
Instance Attributes				
Attribute ID	Name	Data Type	Default Data Value	Access Rule
1	Status	DWORD	1	Get
2	Configuration Capability	DWORD	0	Get
3	Configuration Control	DWORD	0	Get
4	Physical Link Object Structure of: Path Size Path	UINT Array Of WORD	2 0x20F6 0x2401	Get
5	Interface Configuration Structure of: IP Address Network Mask Gateway Address Name Server Name Server 2 Domain Name Size Domain Name	UDINT UDINT UDINT UDINT UDINT UINT STRING	0 0 0 0 0 0 0	Get
6	Host Name Structure of: Host Name Size Host Name	UINT STRING	0 0	Get
Common Services				
Service Code	Implemented for		Service Name	
	Class Level	Instance Level		
0E _{HEX}	Yes	Yes	Get_Attribute_Single	

Ethernet Link Object (F6_{HEX} - 1 Instance)

Class Attributes				
Attribute ID	Name	Data Type	Data Value	Access Rule
1	Revision	UINT	1	Get
Instance Attributes				
Attribute ID	Name	Data Type	Default Data Value	Access Rule
1	Interface Speed	UDINT	100	Get
2	Interface Flags	DWORD	3	Get
3	Physical Address	USINT Array[6]	0	Get
Common Services				
Service Code	Implemented for		Service Name	
	Class Level	Instance Level		
0E _{HEX}	Yes	Yes	Get_Attribute_Single	

Vendor Specific Objects

Bar Code Data Object (70 HEX - 1 Instance)

Class Attributes				
Attribute ID	Name	Data Type	Default Data Value	Access Rule
1	Revision	UINT	1	Get
Instance Attributes				
Attribute ID	Name	Data Type	Default Data Value	Access Rule
1	Bar Code Sequence Number	UINT	0	Get
2	Bar Code Status (reserved)	UINT	0	Get
3	Bar Code Data Size	UINT	0	Get
4	Bar Code Data	UINT[] varies (up to 64)	0	Get
5	Last Bar Code Seq. Num Received	UINT	0	Get / Set
Common Services				
Service Code	Implemented for		Service Name	
	Class Level	Instance Level		
0E _{HEX}	Yes	Yes	Get Attribute Single	
10 _{HEX}	No	Yes	Set Attribute Single	

Discrete Input Data Object (71 HEX - 1 Instance)

Class Attributes				
Attribute ID	Name	Data Type	Default Data Value	Access Rule
1	Revision	UINT	1	Get
Instance Attributes				
Attribute ID	Name	Data Type	Default Data Value	Access Rule
3	Discrete Input Word	UINT	0	Get
Discrete Input Word				
Bit				
0	AL5010 Programmable Output #1			
1	AL5010 Programmable Output #2			
2	AL5010 Programmable Output #3			
3	AL5010 Programmable Output #4			
4	AL5010 Programmable Output #5			
5	AL5010 Programmable Output #6			
6	AL5010 Programmable Output #7			
7	AL5010 Programmable Output #8			
8-15	Unused			
Common Services				
Service Code	Implemented for		Service Name	
	Class Level	Instance Level		
0E _{HEX}	Yes	Yes	Get Attribute Single	

Discrete Output Data Object (72 HEX – 1 Instance)

Class Attributes				
Attribute ID	Name	Data Type	Data Value	Access Rule
1	Revision	UINT	1	Get
Instance Attributes				
Attribute ID	Name	Data Type	Default Data Value	Access Rule
3	Discrete Output Data	UINT	0	Get / Set
Discrete Output Word				
Bit	Bit = 0	Bit = 1		
0*	Trigger Off	Trigger On		
1 – 7	Unused	Unused		
8*	AL5010 Relay #1 Off	AL5010 Relay #1 On		
9*	AL5010 Relay #2 Off	AL5010 Relay #2 On		
10*	AL5010 Relay #3 Off	AL5010 Relay #3 On		
11*	AL5010 Relay #4 Off	AL5010 Relay #4 On		
12-15	Unused	Unused		
* If enabled on AL5010				
Common Services				
Service Code	Implemented for		Service Name	
	Class Level	Instance Level		
0E _{HEX}	Yes	Yes	Get_Attribute_Single	
10 _{HEX}	No	Yes	Set_Attribute_Single	

Notes:

FAST Monitor Configuration

FAST Monitor and AL5010

AccuLazr's user interface provides setup compatibility with Accu-Sort System's **FAST Monitor™**.

FAST Monitor is a browser-based application, running on a FAST Monitor Server, that gives facility managers and maintenance personnel the ability to monitor multiple Accu-Sort products within their facility or across multiple facilities from anywhere an internet connection is available. FAST Monitor provides real time and historical performance data in an easy to use browser interface as well as automatic status and error condition reporting of all Accu-Sort products and systems to which it is connected.

Use the **FAST Monitor Configuration** screen in the user interface to setup an AL5010 reader for FAST Monitor message format compatibility.

How to Configure an AL5010 for FAST Monitor:

1. Open **Modify Settings > Configuration**.

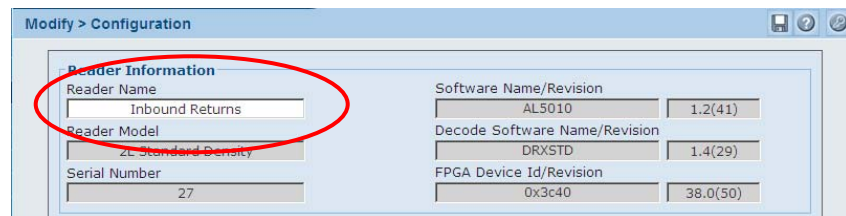

The screenshot shows a web browser window titled "Modify > Configuration". Inside, there is a "Reader Information" section with several input fields. The "Reader Name" field, which contains the text "Inbound Returns", is circled in red. Other fields include "Reader Model" (ZL Standard Density), "Serial Number" (27), "Software Name/Revision" (AL5010, 1.2(41)), "Decode Software Name/Revision" (DRXSTD, 1.4(29)), and "FPGA Device Id/Revision" (0x3c40, 38.0(50)).

- a. Enter a name for the reader in the Reader Name field. Choose a unique name that helps identify that readers scan point.
- b. Click **Update** and then click the save icon.



NOTE: This step needs to be performed with every client scanner in the tunnel.

2. Open **Modify Settings > FAST Monitor**

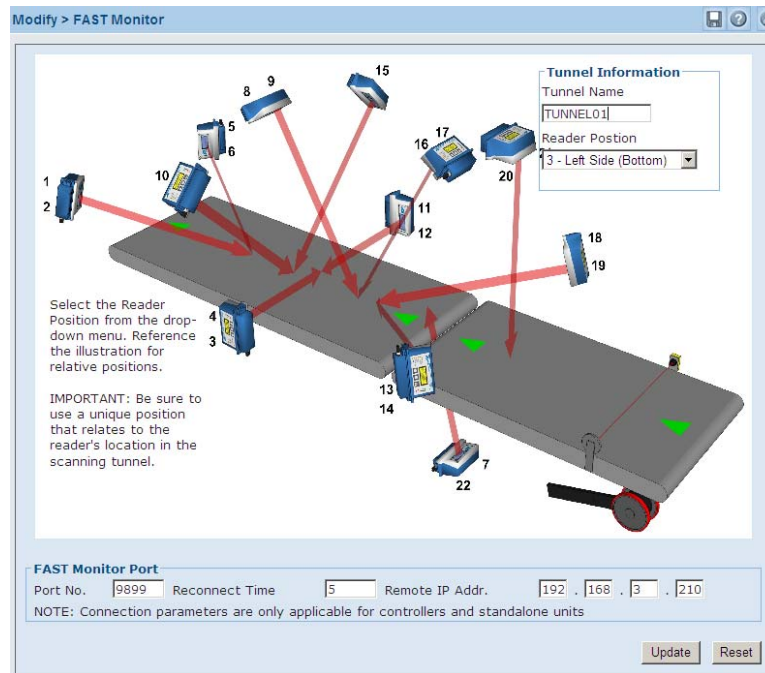

- a. Enter a name for the tunnel in the **Tunnel Name** field.
 - b. Select a reader position from the **Reader Position** drop-down list.
 - c. Enter the FAST Monitor port number in the **Port No.** field (always 9899) and the FAST Monitor IP address in the **Remote IP Addr.** field.
 - d. Click **Update** and then click the save icon.
3. Set up FAST Monitor (refer to the FAST Monitor documentation for setup information.)



NOTE: If multiple units are being used in a network connection, see the Controller/Client section for configuration

Installation Drawings



IMPORTANT: Although AL5010 is easy to install and setup, it is also very robust in its capabilities. If you are interested in additional information on product training, please contact us at 1-800-BAR-CODE.

Any application-specific drawings shipped with the equipment may supersede the drawings provided in this appendix.

AL5010 Installation Drawings

The drawings provided in this appendix are useful when mechanically and electrically installing the AccuLazr AL5010.

Mechanical Installation Drawings

- AL5010 Scanner Mechanical Specification (111584)
- AL5010 Mechanical Installation (111585)
 - AL5010 Mounting Dimensions (sheet 1)
 - AL5010 Mounting with Universal Mounting Bracket (sheet 2)
- Kit, Universal Mounting Bracket, AL5010 (111620)
- Basic Interface Module Specification (111632)
- Enhanced Interface Module Specification (111634)
- Photoeye Mounting (for Accu-Sort Structures) (41222)
- Photoeye Mounting (24130)
- Tachometer Mounting with Anti-Static Brush (102974)

Electrical Installation Drawings

- Interconnect: AL5010 with Enhanced Interface Module (113490)
 - Interconnections of AL5010 (sheet 1)
 - Power, Trigger and Tachometer Options (sheet 2)
 - Start and End Trigger Photoeyes (sheet 3)
 - Computed Tach and Trigger (sheet 4)
 - Serial, DeviceNet or Profibus Communications (sheet 5)
- AL5010 Controller / Client Interconnections (113492)
- AL5010 Connector Pin-Outs Diagram (113493)

Notes:

NOTES:
 1) WEIGHT: HEAD AND BASE .78KG [1.72LBS]
 HEAD ONLY .50KG [1.10 LBS]
 2) FOR RASTERING VERSION ONLY

REV	CHANGE	BY	DATE
1	RELEASED	TJB	11OCT2010

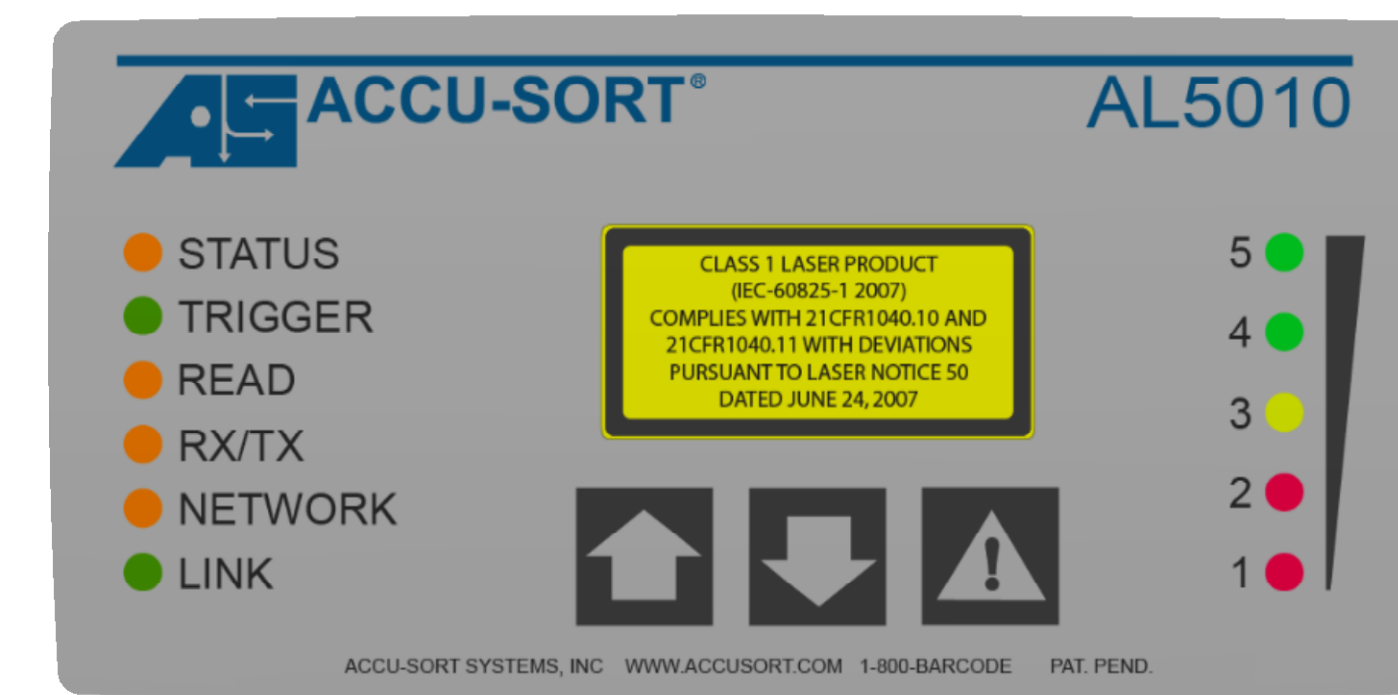
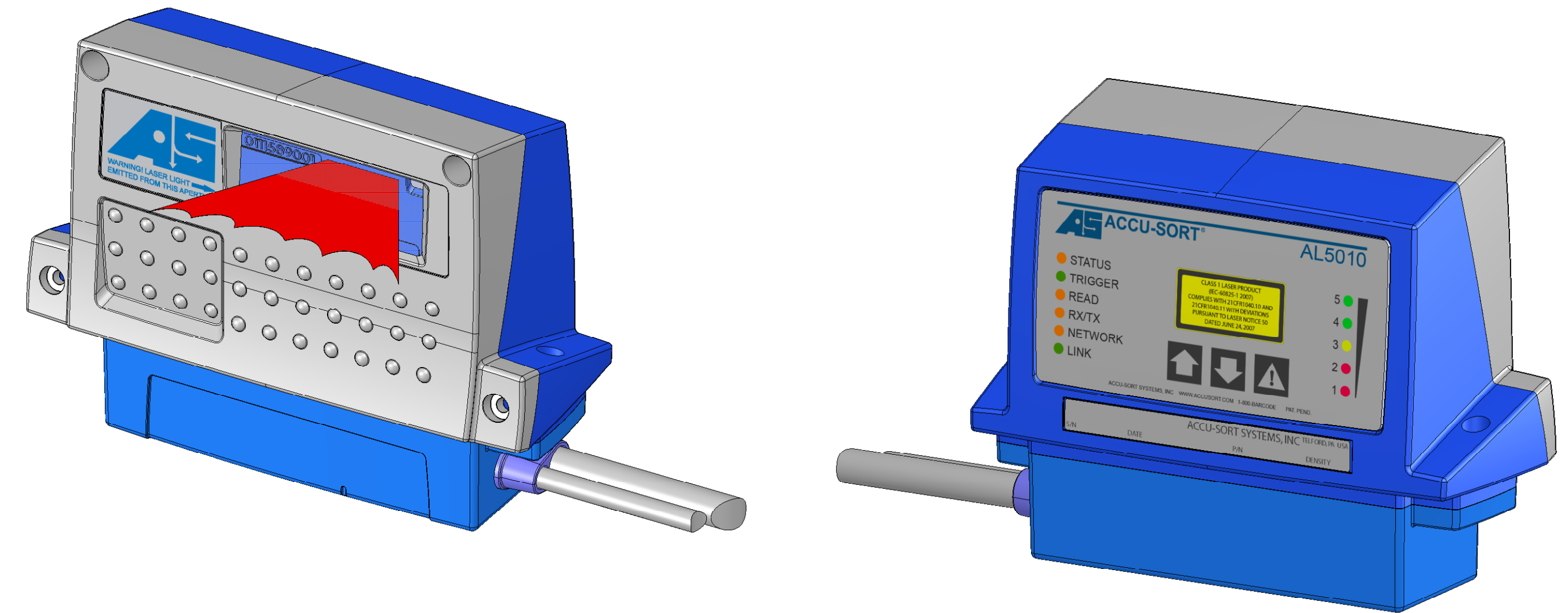
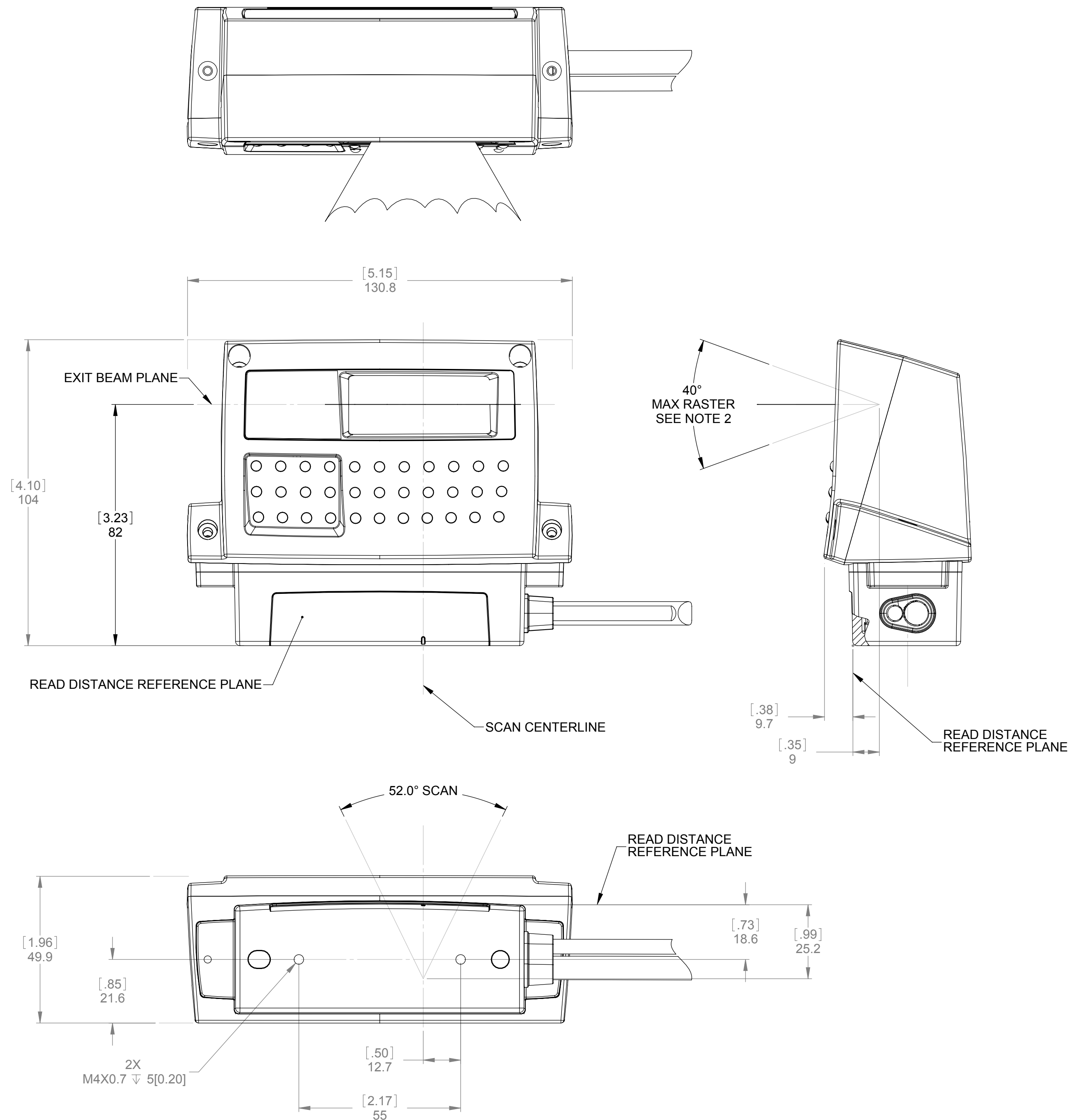

DISPLAY

REFERENCE DRAWINGS
 111407 EXPLODED PARTS DIAGRAM, SCANNER - AL5010
 111585 INSTALLATION DRAWING - AL5010

PART NO. 0111584001		METRIC		DRAWN TJB DATE 11.16.07		ACCU-SORT [®] SYSTEMS, inc. TELFORD, PA 18969 USA	
THIS IS NOT A CONTROLLED COPY UNLESS STAMPED "CONTROLLED COPY" IN RED		UNLESS OTHERWISE SPECIFIED DIMENSIONS ARE IN MILLIMETERS(INCHES) ALL ANGLES ARE 90° REMOVE BURRS AND SHARP EDGES		CHKD	DATE	MECHANICAL SPECIFICATIONS	
THIS DOCUMENT IS PROVIDED FOR A SPECIFIC PURPOSE AND THE DISCLOSED INFORMATION REMAINS OUR PROPERTY. IT MAY NOT BE DISCLOSED, COPIED, OR REPRODUCED, EXCEPT FOR THE SPECIFIC PURPOSE. WITHOUT ACCU-SORT'S PRIOR APPROVAL. THIS NOTICE MUST APPEAR ON ANY COPY OR REPRODUCTION OF THIS DOCUMENT. © 2007 ACCU-SORT SYSTEMS, INC.		TOLERANCES: MM [INCH] X±2.500 [X±.1000] X±0.500 [X±.0200] X±0.130 [X±.0050] XXX±0.013 [XXXX±.0005]		ENGR TJB	DATE 11.16.07	AL5010	
				DEPT.	MECH ENG		
				E-	N/A		
				CUSTOMER	N/A	SIZE D	CAGE CODE 53830
				CONTRACT #	N/A	DWG NO.	111584
						SCALE	NONE
						CAD SYS.	SOLIDWORKS
						SHEET	1 OF 1

- NOTES:
 1) TILT: MOUNTED WITH ARC SLOTS: $\pm 22.5^\circ$
 MOUNTED WITH CENTER HOLE: $\pm 180^\circ$
 2) MOUNTING HARDWARE (INCLUDED WITH UNIVERSAL MOUNTING BRACKET):
 2X M5 SCREW, WASHER AND Z-NUT FOR EXTRUSION MOUNTING (SHOWN)
 2X #10 SELF-DRILLING SCREW FOR SURFACE MOUNTING (NOT SHOWN)
 1X 5/16-18 T-STUD AND FLANGED BUT FOR EXTRUSION MOUNTING WITH $\pm 180^\circ$ ROTATION

REV		CHANGE	BY	DATE
2		ECO 11-65, REVISED AS SHOWN	TJB	10FEB2011

REVISION

PITCH $\pm 15^\circ$

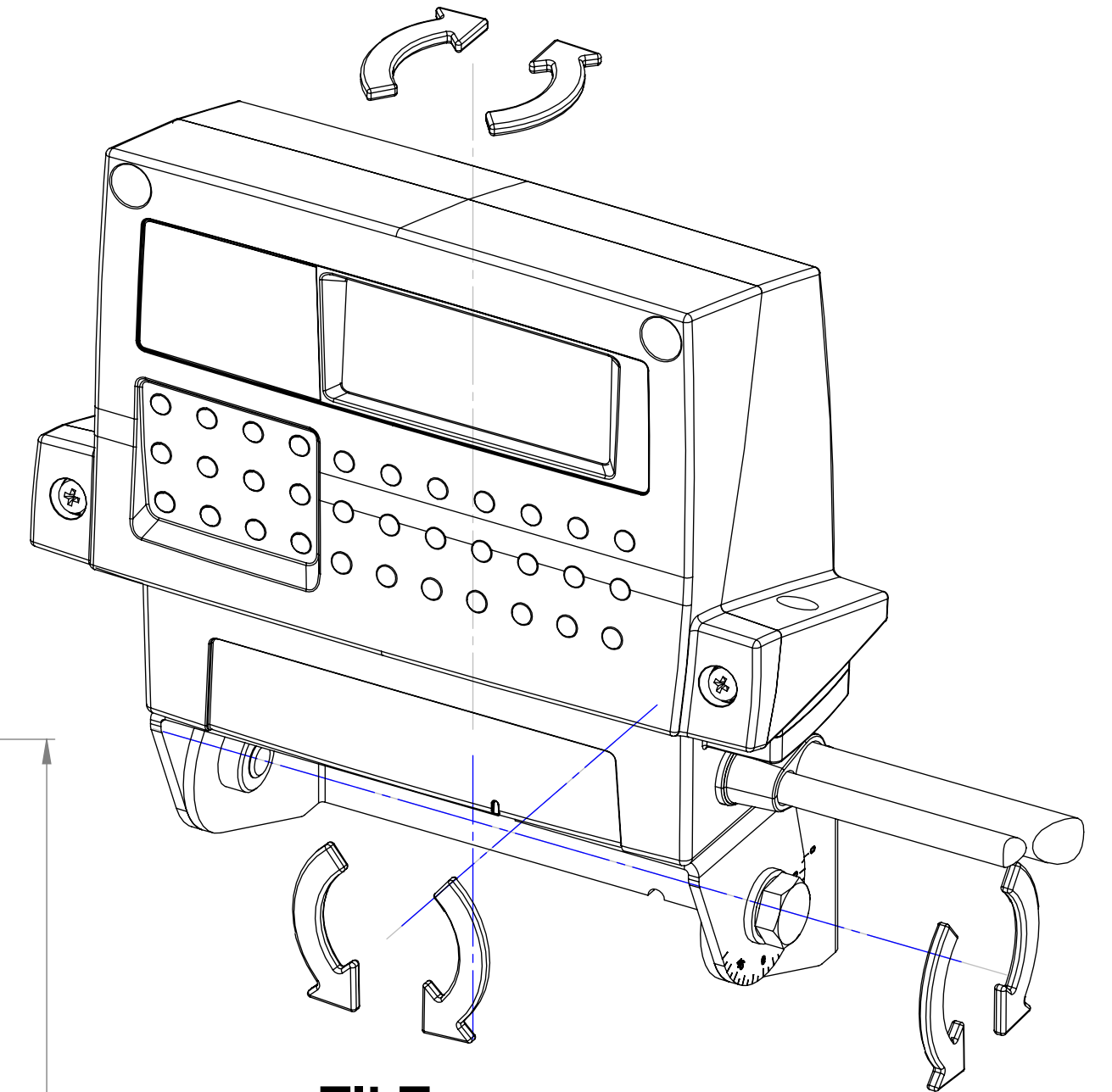

**TILT
SEE NOTE 1**

**SKEW
 $+150^\circ/-8^\circ$**

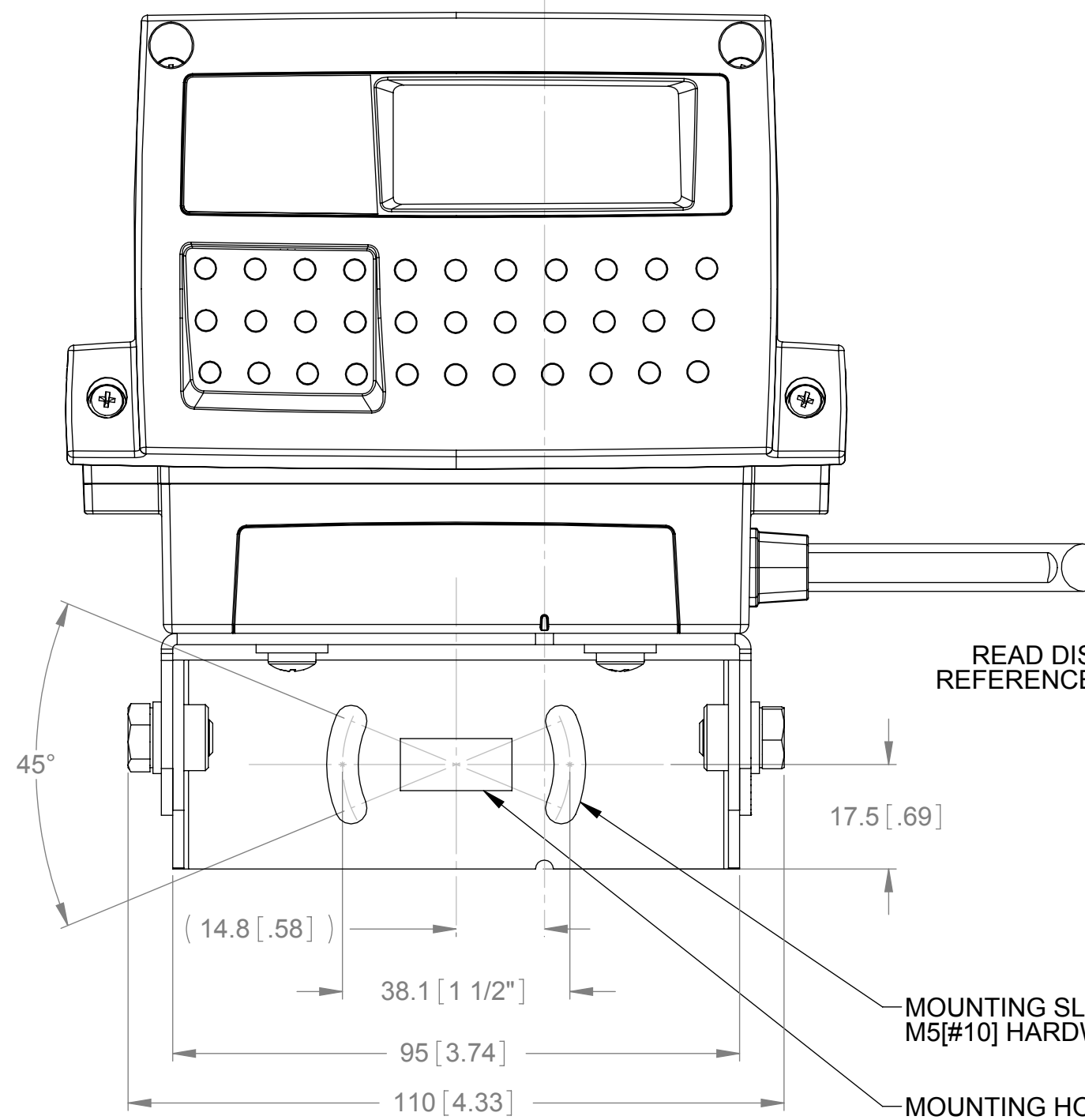
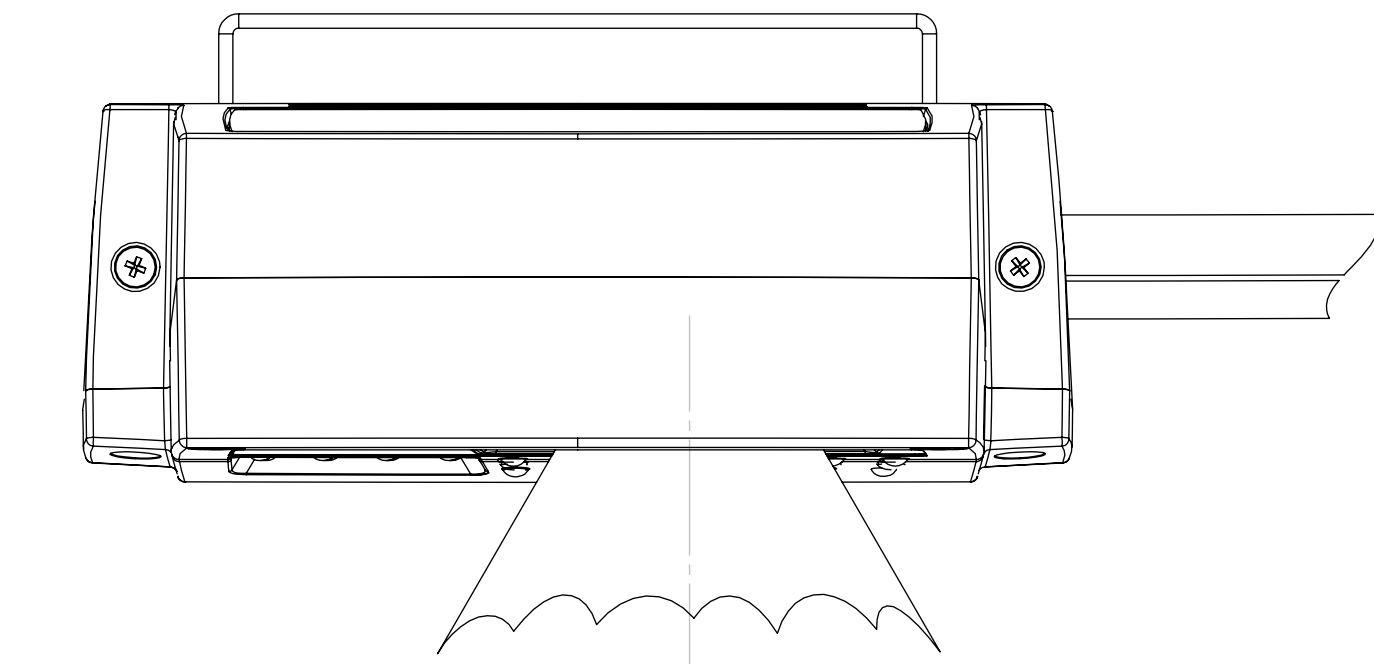

READ DISTANCE
REFERENCE POINT

MOUNTING SLOTS FOR
M5[#10] HARDWARE

MOUNTING HOLE FOR
5/16 T-STUD

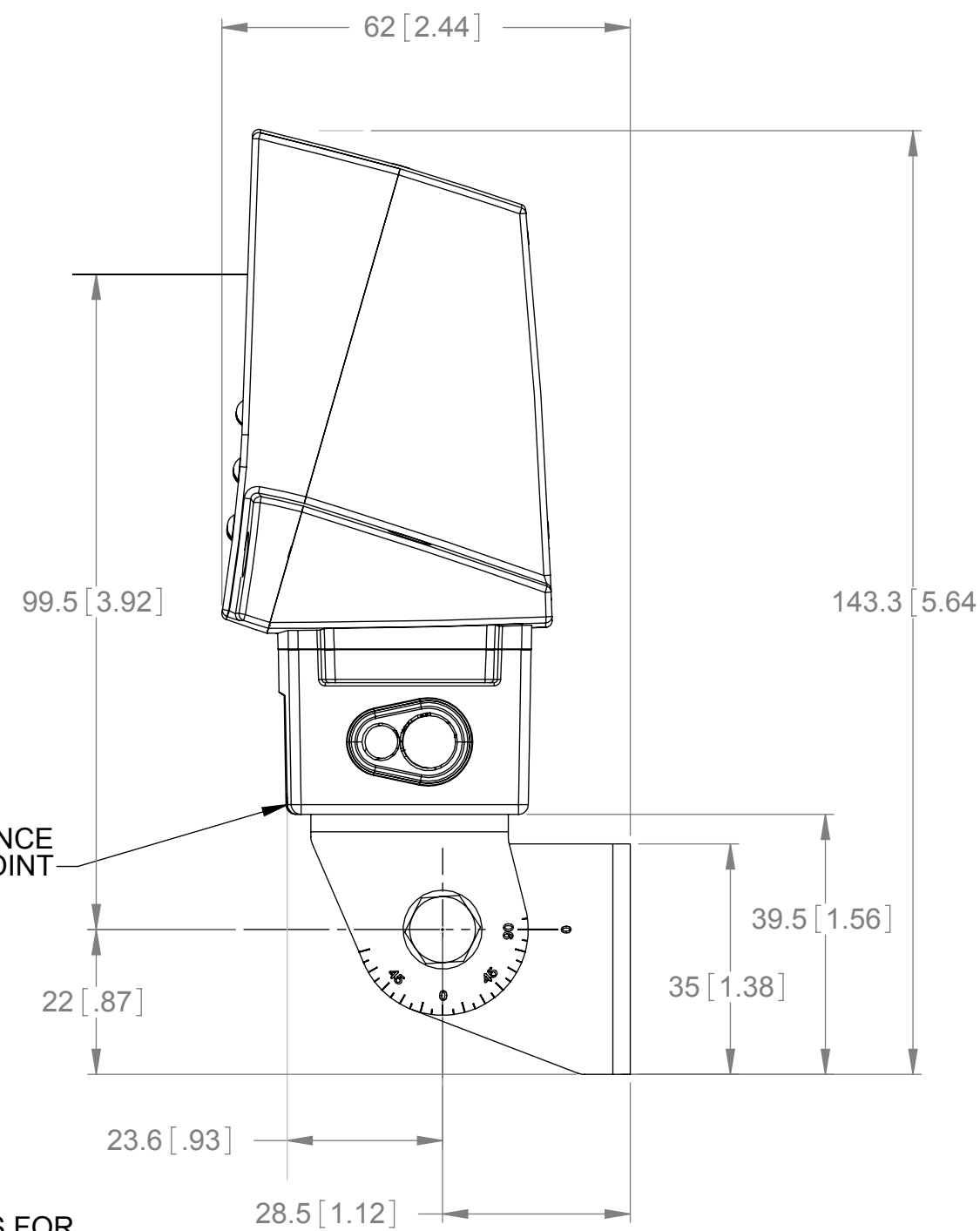

PART NO. --

METRIC

THIS IS NOT A CONTROLLED COPY UNLESS STAMPED "CONTROLLED COPY" IN RED
 THIS DOCUMENT IS PROVIDED FOR A SPECIFIC PURPOSE AND THE DISCLOSED INFORMATION REMAINS OUR PROPERTY. IT MAY NOT BE DISCLOSED, COPIED, OR REPRODUCED, EXCEPT FOR THE SPECIFIC PURPOSE. WITHOUT ACCU-SORT'S PRIOR APPROVAL. THIS NOTICE MUST APPEAR ON ANY COPY OR REPRODUCTION OF THIS DOCUMENT.
 © 2007, ACCU-SORT SYSTEMS, INC.

UNLESS OTHERWISE SPECIFIED DIMENSIONS ARE IN MILLIMETERS[INCHES] ALL ANGLES ARE 90° REMOVE BURRS AND SHARP EDGES

TOLERANCES:		ANGULAR
METRIC	[INCH]	
X \pm 2.500	[X \pm 1/1000]	X \pm 1.00°
X \pm 0.500	[XX \pm 0.0200]	X \pm 0.10°
.XX \pm 0.130	[XXX \pm 0.0050]	.XX \pm 0.01°
.XXX \pm 0.013	[XXXX \pm 0.0005]	

DRAWN	TJB	DATE	01.31.08
CHKD		DATE	
ENGR	TJB	DATE	01.31.08
DEPT.	MECH ENG		
E-	N/A		
CUSTOMER	N/A		
CONTRACT #	N/A		

ACCU-SORT® SYSTEMS, inc.
 TELFORD, PA 18969 USA

INSTALLATION DRAWING
AL5010

SIZE	CAGE CODE	DWG. NO.	111585
C	53830		
SCALE	NONE	CAD SYS.	SOLIDWORKS
SHEET	1	OF	2

REFERENCE DRAWINGS
 111584 MECHANICAL SPECIFICATIONS
 111407 EXPLODED PARTS DIAGRAM

AL5010
SCAN HEAD
0111625xxx

AL5010
SCAN BASE
0111623001

UNIVERSAL MOUNTING
BRACKET KIT
P/N 0111620001
SEE NOTE 2

MOUNTING EXTRUSION
(SUPPLIED SEPERATELY)

M4 MOUNTING HARDWARE
SUPPLIED WITH SCAN BASE

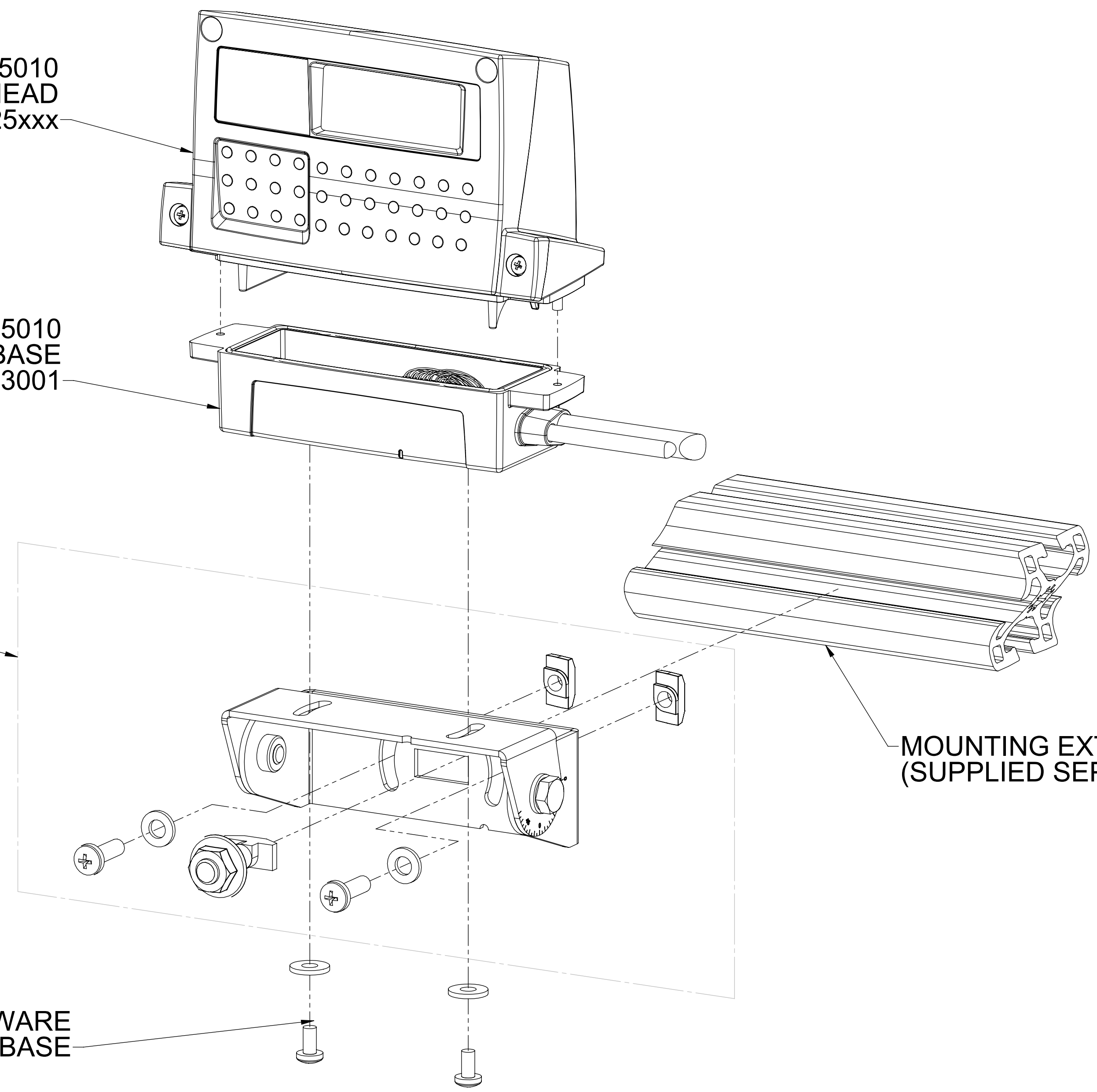

PART NO. 0111585001

METRIC

THIS IS NOT A CONTROLLED COPY UNLESS STAMPED "CONTROLLED COPY" IN RED
THIS DOCUMENT IS PROVIDED FOR A SPECIFIC PURPOSE AND THE DISCLOSED INFORMATION REMAINS OUR PROPERTY. IT MAY NOT BE DISCLOSED, COPIED, OR REPRODUCED, EXCEPT FOR THE SPECIFIC PURPOSE, WITHOUT ACCU-SORT'S PRIOR APPROVAL. THIS NOTICE MUST APPEAR ON ANY COPY OR REPRODUCTION OF THIS DOCUMENT.
© 2007, ACCU-SORT SYSTEMS, INC.

UNLESS OTHERWISE SPECIFIED DIMENSIONS ARE IN MILLIMETERS[INCHES] ALL ANGLES ARE 90° REMOVE BURRS AND SHARP EDGES

TOLERANCES:		ANGULAR
METRIC	[INCH	
X±2.500	[.X±.1000]	X±1.00°
X±0.500	[.XX±.0200]	X±0.10°
.XX±0.130	[.XXX±.0050]	.XX±0.01°
.XXX±0.013	[.XXXX±.0005]	

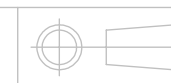

DRAWN	TJB	DATE	01.31.08
CHKD		DATE	
ENGR	TJB	DATE	01.31.08
DEPT.	MECH ENG		
E-	N/A		
CUSTOMER	N/A		
CONTRACT #	N/A		

 ACCU-SORT® SYSTEMS, inc.
TELFORD, PA 18969 USA

INSTALLATION DRAWING
AL5010

SIZE	CAGE CODE	DWG. NO.
C	53830	111585
SCALE	NONE	CAD SYS. SOLIDWORKS
SHEET		2 OF 2

NOTES:
 1) ITEM NUMBERS APPLY TO THIS DRAWING ONLY
 2) ITEMS 6 THRU 9 TO BE BAGGED SEPARATELY

1 REVISION			
REV	CHANGE	BY	DATE
2	ECO 11-65 REVISED AS SHOWN	TJB	10FEB2011

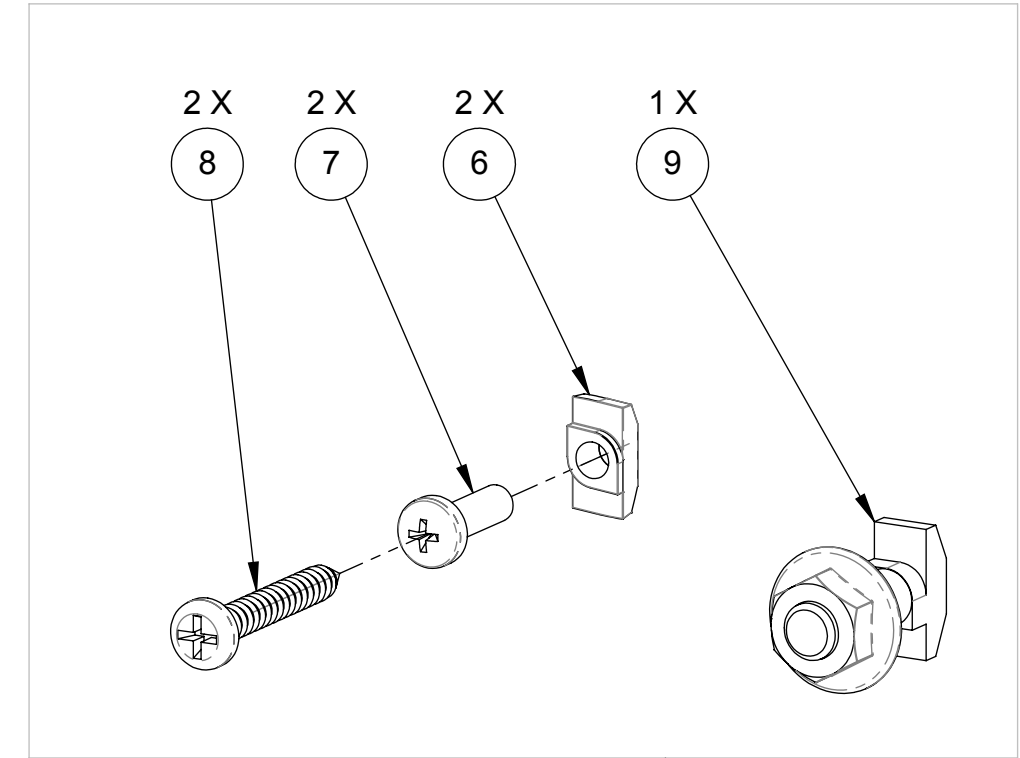
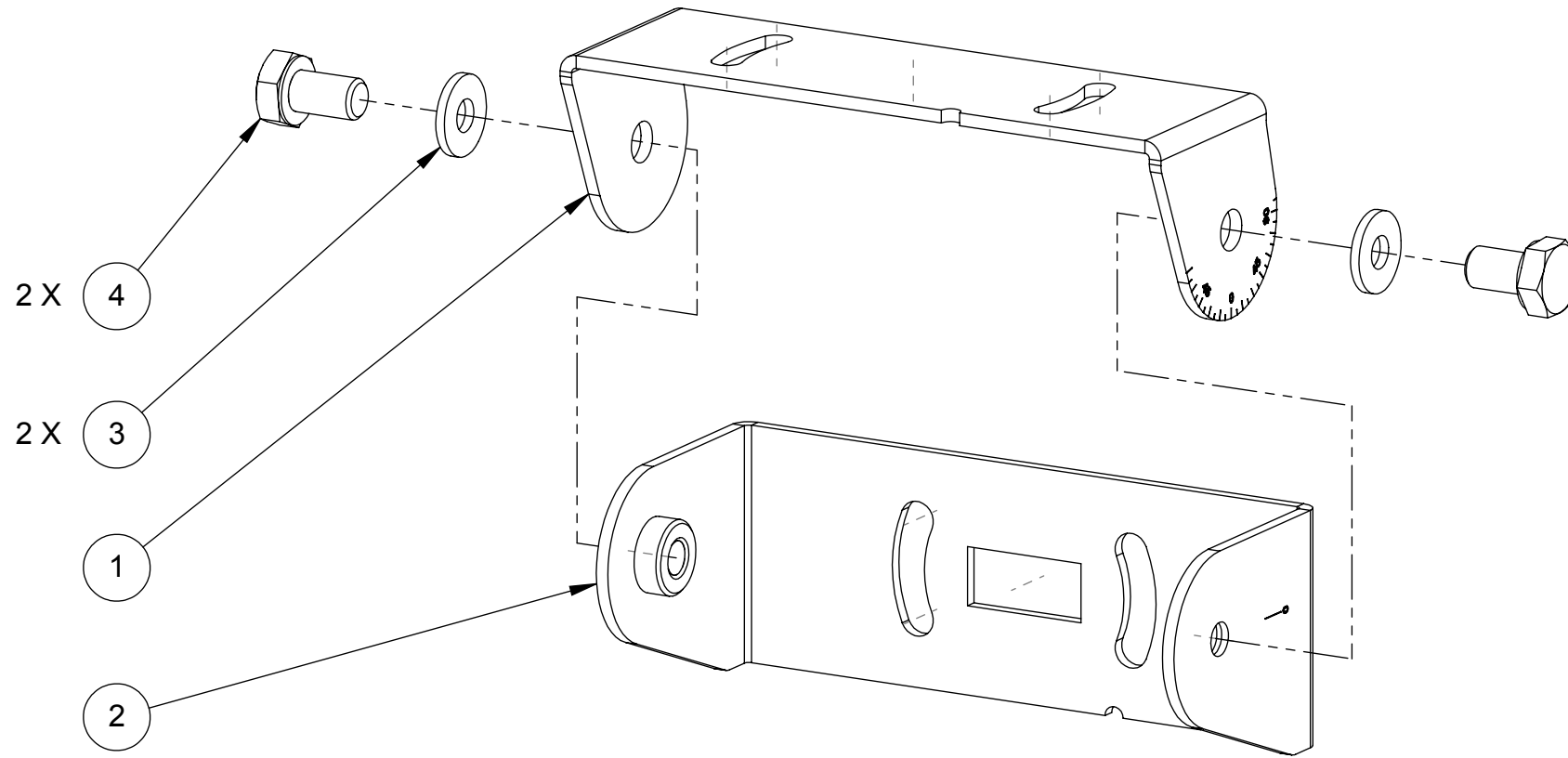

SEE NOTE 2

ITEM	QTY	PART NO	DESCRIPTION
9	1	0110361001	5/16-18 T-STUD AND FLANGED NUT
8	2	1000068551	#10-16 1"LG PAN HD PHIL SELF DRILLING SCREW, S/S
7	2	1000069351	PMHS M5X.8 10MM LG, PHIL, STAINLESS STEEL
6	2	1000068227	Z-NUT, M5X.8
5			
4	2	100069798	HHCS, M6X1.0 10 LG STAINLESS STEEL
3	2	1000068330	WAVE WASHER, 12MM OD X 6.4MM ID X .5MM THK, SS
2	1	0111622001	BRACKET, UMB LOWER
1	1	0111621001	BRACKET, UMB UPPER

PART NO. 0111620001

METRIC

THIS IS NOT A CONTROLLED COPY UNLESS STAMPED "CONTROLLED COPY" IN RED

THIS DOCUMENT IS PROVIDED FOR A SPECIFIC PURPOSE AND THE DISCLOSED INFORMATION REMAINS OUR PROPERTY. IT MAY NOT BE DISCLOSED, COPIED, OR REPRODUCED, EXCEPT FOR THE SPECIFIC PURPOSE, WITHOUT ACCU-SORT'S PRIOR APPROVAL. THIS NOTICE MUST APPEAR ON ANY COPY OR REPRODUCTION OF THIS DOCUMENT.
 © 2007 ACCU-SORT SYSTEMS, INC.

UNLESS OTHERWISE SPECIFIED DIMENSIONS ARE IN MILLIMETERS [INCHES] ALL ANGLES ARE 90° REMOVE BURRS AND SHARP EDGES

TOLERANCES:		
MM	[INCH]	ANGULAR
X±2.500	[.X±.1000]	X±1.00°
.X±0.500	[.XX±.0200]	.X±0.10°
.XX±0.130	[.XXX±.0050]	.XX±0.01°
.XXX±0.013	[.XXXX±.0005]	

DRAWN	TJB	DATE	01.31.08
CHKD	XXX	DATE	XX.XX.XX
ENGR	TJB	DATE	01.31.08
DEPT.	MECH ENG		
E-	N/A		
CUSTOMER	N/A		
CONTRACT #	N/A		

ACCU-SORT® SYSTEMS, inc.
 TELFORD, PA 18969 USA

KIT, UNIVERSAL MOUNTING BRACKET
 AL5010

SIZE B CAGE CODE 53830 DWG. NO. 111620

SCALE NONE CAD SYS. SOLIDWORKS SHEET 1 OF 1

NOTES:

- 1) WEIGHT: .29KGS [.58LBS]
- 2) ENVIRONMENTAL RATING: IP65
- 3) INCLUDED MOUNTING HARDWARE:
 2X M5 SCREW AND Z-NUT FOR EXTRUSION MOUNTING (SHOWN)
 2X #10 SELF-DRILLING SCREW FOR SURFACE MOUNTING (NOT SHOWN)

REVISION			
REV	CHANGE	BY	DATE
1	RELEASED 10-263	TJB	14OCT2010

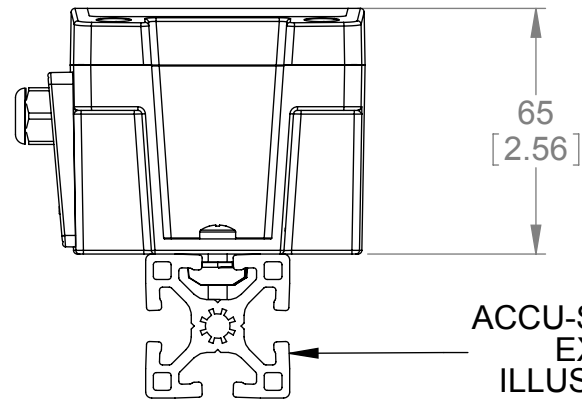
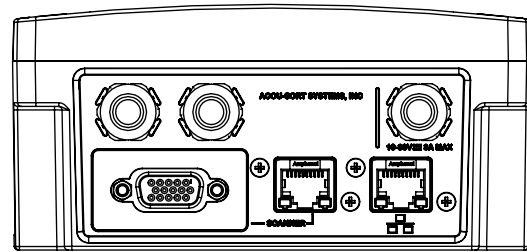
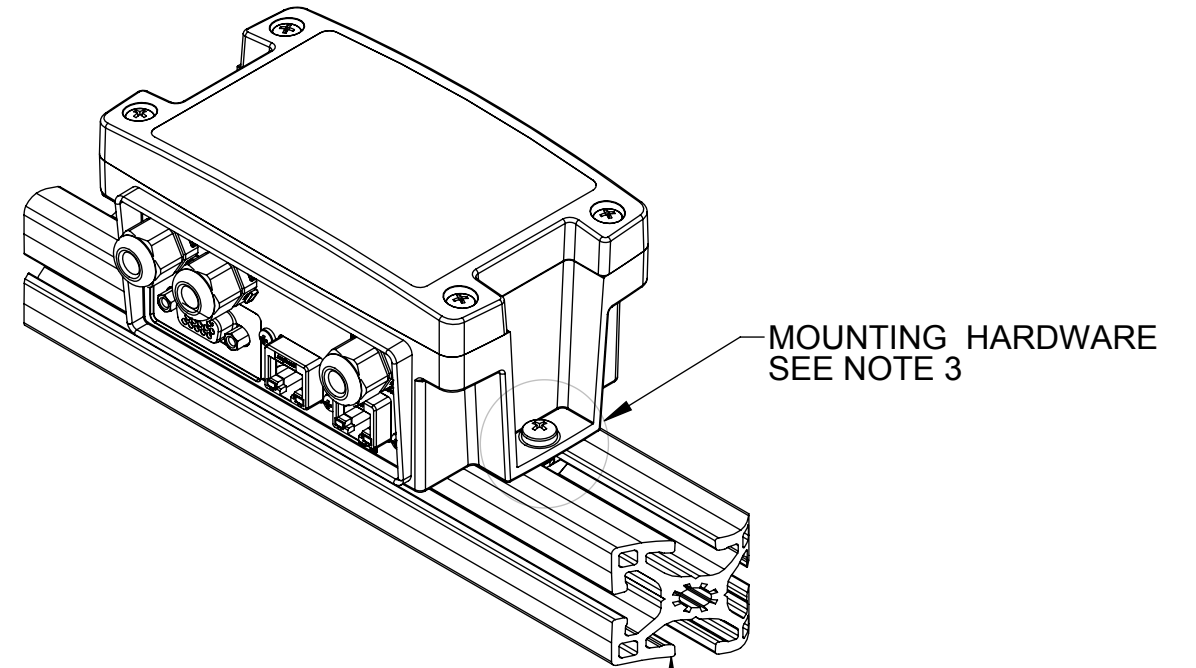
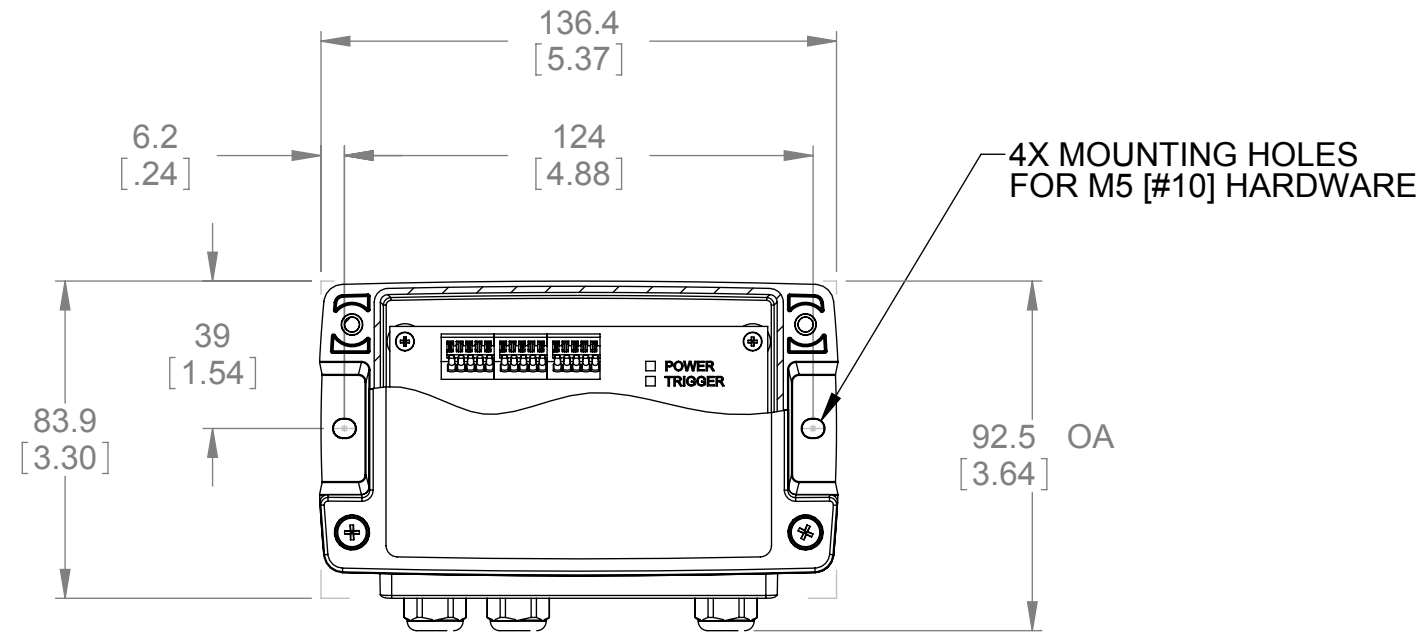

PART NO. 0111632001

METRIC

THIS IS NOT A CONTROLLED COPY UNLESS STAMPED "CONTROLLED COPY" IN RED

UNLESS OTHERWISE SPECIFIED DIMENSIONS ARE IN MILLIMETERS [INCHES] ALL ANGLES ARE 90° REMOVE BURRS AND SHARP EDGES

THIS DOCUMENT IS PROVIDED FOR A SPECIFIC PURPOSE AND THE DISCLOSED INFORMATION REMAINS OUR PROPERTY. IT MAY NOT BE DISCLOSED, COPIED, OR REPRODUCED, EXCEPT FOR THE SPECIFIC PURPOSE, WITHOUT ACCU-SORT'S PRIOR APPROVAL. THIS NOTICE MUST APPEAR ON ANY COPY OR REPRODUCTION OF THIS DOCUMENT.
 © 2007 ACCU-SORT SYSTEMS, INC.

TOLERANCES:		
METRIC	[INCH	ANGULAR
X±2.500	[.X±.1000]	X±1.00°
.X±0.500	[.XX±.0200]	.X±0.10°
.XX±0.130	[.XXX±.0050]	.XX±0.01°
.XXX±0.013	[.XXXX±.0005]	

DRAWN	TJB	DATE	04.04.08
CHKD		DATE	
ENGR	TJB	DATE	04.04.08
DEPT.	MECH ENG		
E-	N/A		
CUSTOMER	N/A		
CONTRACT #	N/A		



ACCU-SORT® SYSTEMS, inc.
 TELFORD, PA 18969 USA

**MECHANICAL SPECIFICATIONS
 BASIC INTERFACE MODULE - AL5010**

SIZE	CAGE CODE	DWG. NO.
B	53830	111632
SCALE	CAD SYS.	SHEET
NONE	SOLIDWORKS	1 OF 1

REFERENCE DRAWINGS
 111631 ASSEMBLY, BASIC INTERFACE MODULE

4

3

2

1

NOTES:

- 1) WEIGHT: .52KGS [1.14LBS]
- 2) ENVIRONMENTAL RATING: IP65
- 3) INCLUDED MOUNTING HARDWARE:
 4X M5 SCREW AND Z-NUT FOR EXTRUSION MOUNTING (SHOWN)
 4X #10 SELF-DRILLING SCREW FOR SURFACE MOUNTING (NOT SHOWN)

REVISION			
REV	CHANGE	BY	DATE
1	RELEASED 10-263	TJB	14OCT2010

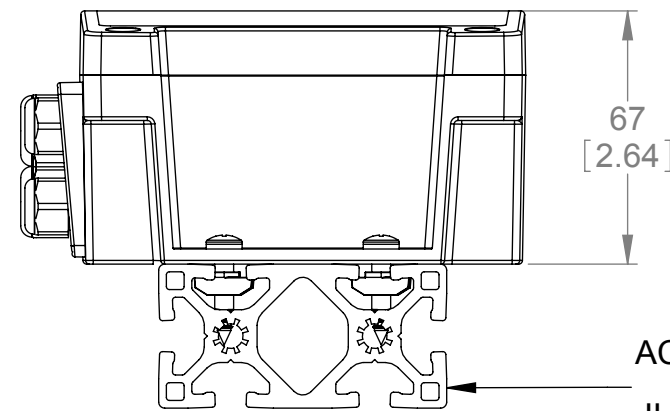
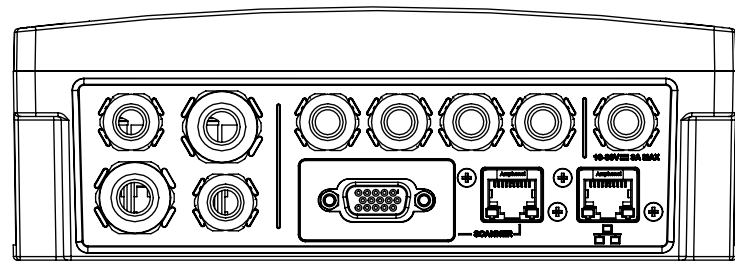
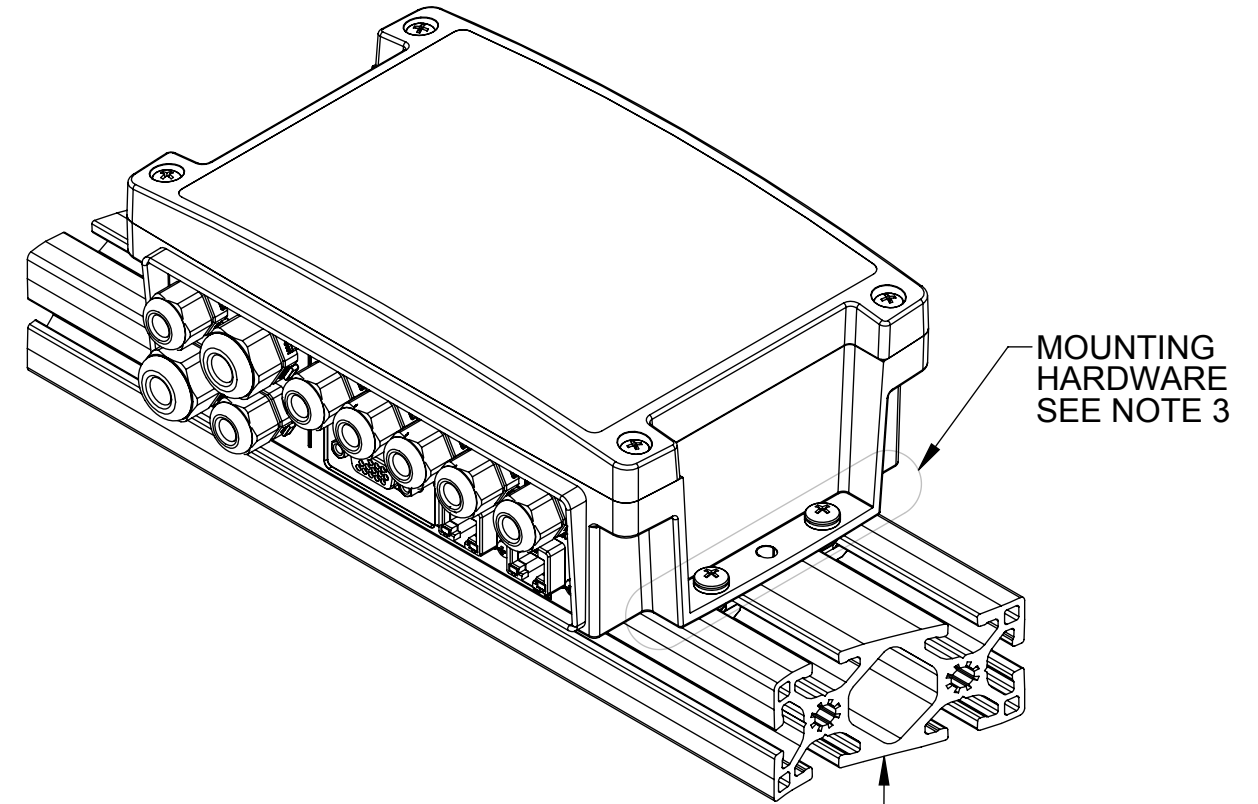
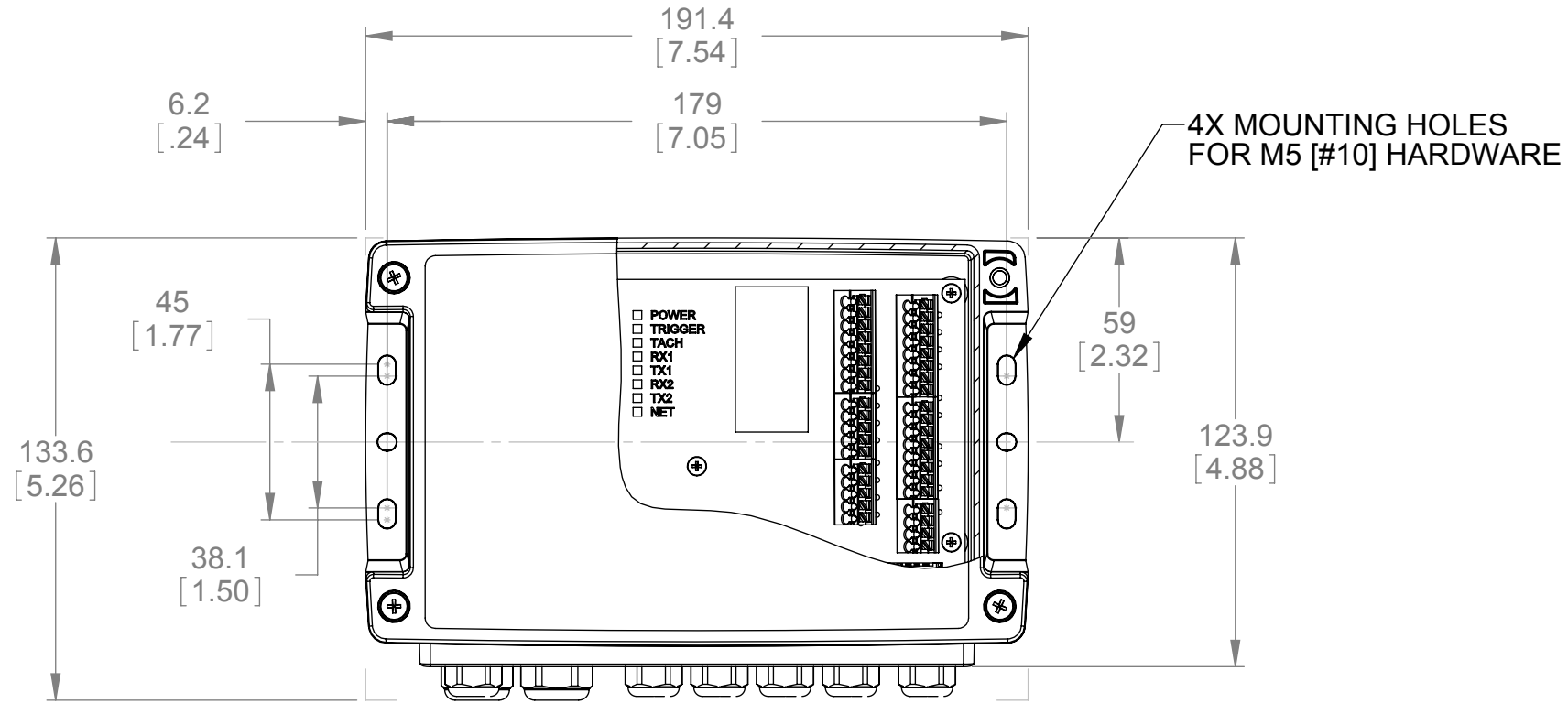

ACCU-SORT 1.5"X3" STRUCTURAL EXTRUSION SHOWN FOR ILLUSTRATION PURPOSES ONLY

PART NO. 0111634001

METRIC

THIS IS NOT A CONTROLLED COPY UNLESS STAMPED "CONTROLLED COPY" IN RED

UNLESS OTHERWISE SPECIFIED DIMENSIONS ARE IN MILLIMETERS [INCHES] ALL ANGLES ARE 90° REMOVE BURRS AND SHARP EDGES

THIS DOCUMENT IS PROVIDED FOR A SPECIFIC PURPOSE AND THE DISCLOSED INFORMATION REMAINS OUR PROPERTY. IT MAY NOT BE DISCLOSED, COPIED, OR REPRODUCED, EXCEPT FOR THE SPECIFIC PURPOSE, WITHOUT ACCU-SORT'S PRIOR APPROVAL. THIS NOTICE MUST APPEAR ON ANY COPY OR REPRODUCTION OF THIS DOCUMENT.
 © 2007 ACCU-SORT SYSTEMS, INC.

TOLERANCES:		
METRIC	[INCH	ANGULAR
X±2.500	[.X±.1000]	X±1.00°
.X±0.500	[.XX±.0200]	.X±0.10°
.XX±0.130	[.XXX±.0050]	.XX±0.01°
.XXX±0.013	[.XXXX±.0005]	

DRAWN	TJB	DATE	04.04.08
CHKD		DATE	
ENGR	TJB	DATE	04.04.08
DEPT.	MECH ENG		
E-	N/A		
CUSTOMER	N/A		
CONTRACT #	N/A		



ACCU-SORT® SYSTEMS, inc.
 TELFORD, PA 18969 USA

MECHANICAL SPECIFICATIONS
 ENHANCED INTERFACE MODULE - AL5010

SIZE	CAGE CODE	DWG. NO.	111634
B	53830		
SCALE	NONE	CAD SYS.	SOLIDWORKS
SHEET	1	OF	1

REFERENCE DRAWINGS
 111633 ASSEMBLY, ENHANCED INTERFACE MODULE

4

3

2

1

REVISION			
REV	CHANGE	BY	DATE
05	ECO 10-3	AS	02/17/10

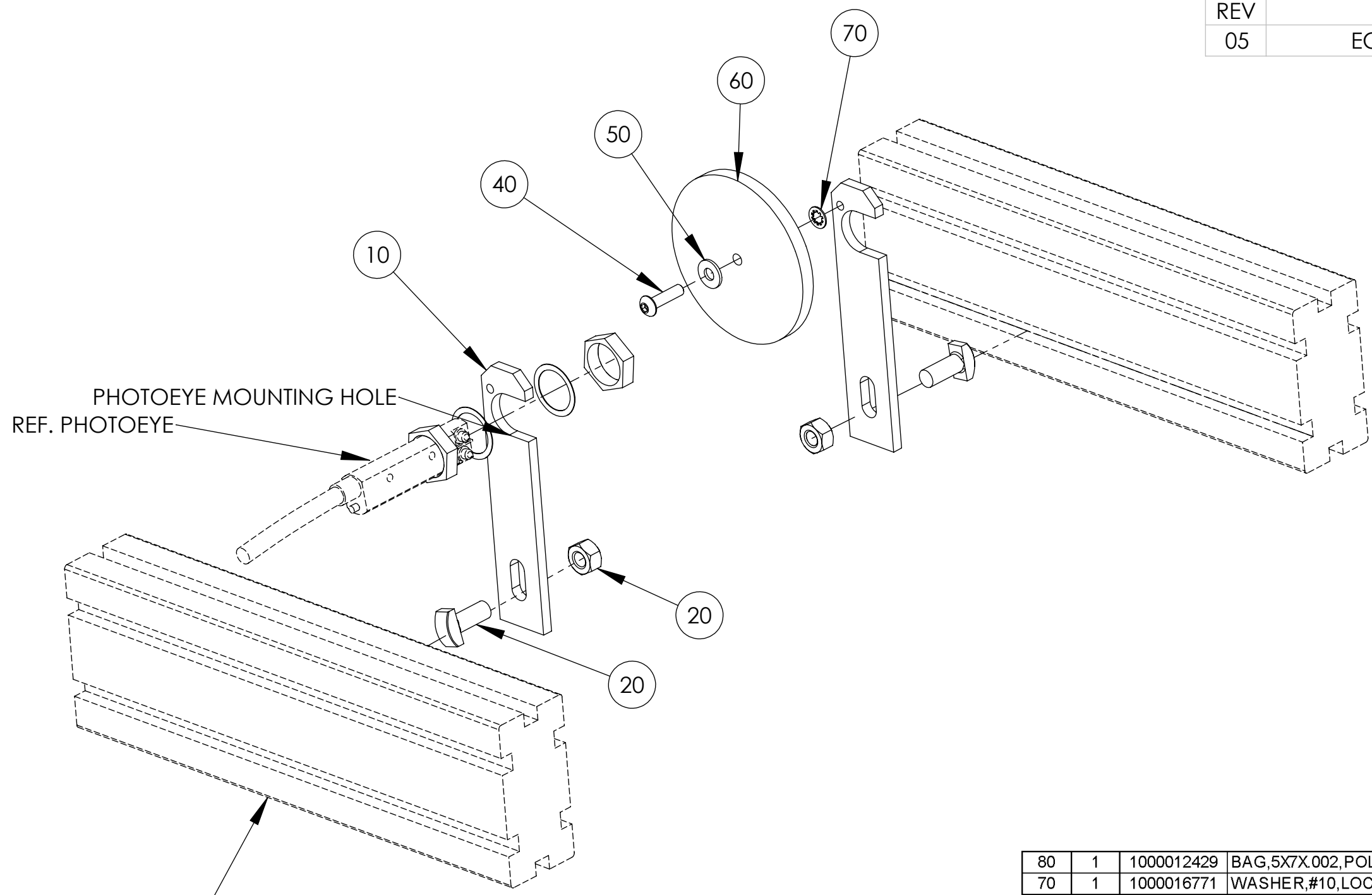

REF. 1.5" X 3.0" EXTRUSION (2)

ITEM	QTY.	PART NO.	DESCRIPTION
80	1	1000012429	BAG, 5X7X.002, POLY (NOT SHOWN)
70	1	1000016771	WASHER, #10, LOCK, INTERNAL TOOTH,,
60	1	1000013792	REFLECTOR, 3 INCH
50	1	1000022099	WASHER, #10, FLAT
40	1	1000005781	SCREW, 10-32, 3/4, HEX, CAP, BUTTON HEAD, STEEL, BLACK OXIDE
20	2	0110361001	ASSEMBLY, 1PK, 3/4IN, T-STUD AND FLANGED NUT
10	2	1000008700	PLATE, STRAIGHT, PHOTOEYE/REFLECTOR

PART NO. 1000020589

THIS IS NOT A CONTROLLED COPY UNLESS STAMPED "CONTROLLED COPY" IN RED

THIS DOCUMENT IS PROVIDED FOR A SPECIFIC PURPOSE AND THE DISCLOSED INFORMATION REMAINS OUR PROPERTY. IT MAY NOT BE DISCLOSED, COPIED, OR REPRODUCED, EXCEPT FOR THE SPECIFIC PURPOSE, WITHOUT ACCU-SORT'S PRIOR APPROVAL. THIS NOTICE MUST APPEAR ON ANY COPY OR REPRODUCTION OF THIS DOCUMENT.

© 2007 ACCU-SORT SYSTEMS, INC.

UNLESS OTHERWISE SPECIFIED DIMENSIONS ARE IN INCHES [MILLIMETERS]
 ALL ANGLES ARE 90°
 ALL C-CINKS ARE 82° INCLUDED ANGLE
 ALL BEND RELIEFS TO SUIT

TOLERANCES:

INCH	[METRIC]	ANGULAR
.X±.1000	[X±2.500]	X±1.00°
.XX±.0200	[.X±0.500]	.X±.10°
.XXX±.0050	[.XX±0.130]	.XX±.01°
.XXXX±.0005	[.XXX±0.013]	

FRACTIONS ±1/4
 FT., IN ±1"

REMOVE SHARP EDGES AND BURRS

DRAWN	AS	DATE	01/16/09
CHKD	XXX	DATE	XX.XX.XX
ENGR	AS	DATE	XX.XX.XX
DEPT.	MECH ENG		
E-	N/A		
CUSTOMER	N/A		
CONTRACT #	N/A		

ACCU-SORT® SYSTEMS, inc.
 TELFORD, PA 18969 USA

KIT, MOUNTING, REFLECTOR
 PHOTOEYE

SIZE	CAGE CODE	DWG. NO.
B	53830	41222

SCALE NONE CAD SYS. SOLIDWORKS SHEET 1 OF 1

REVISIONS			
REV	ECO	BY	DATE
5	05-1323	CDG/TCS	12.07.05

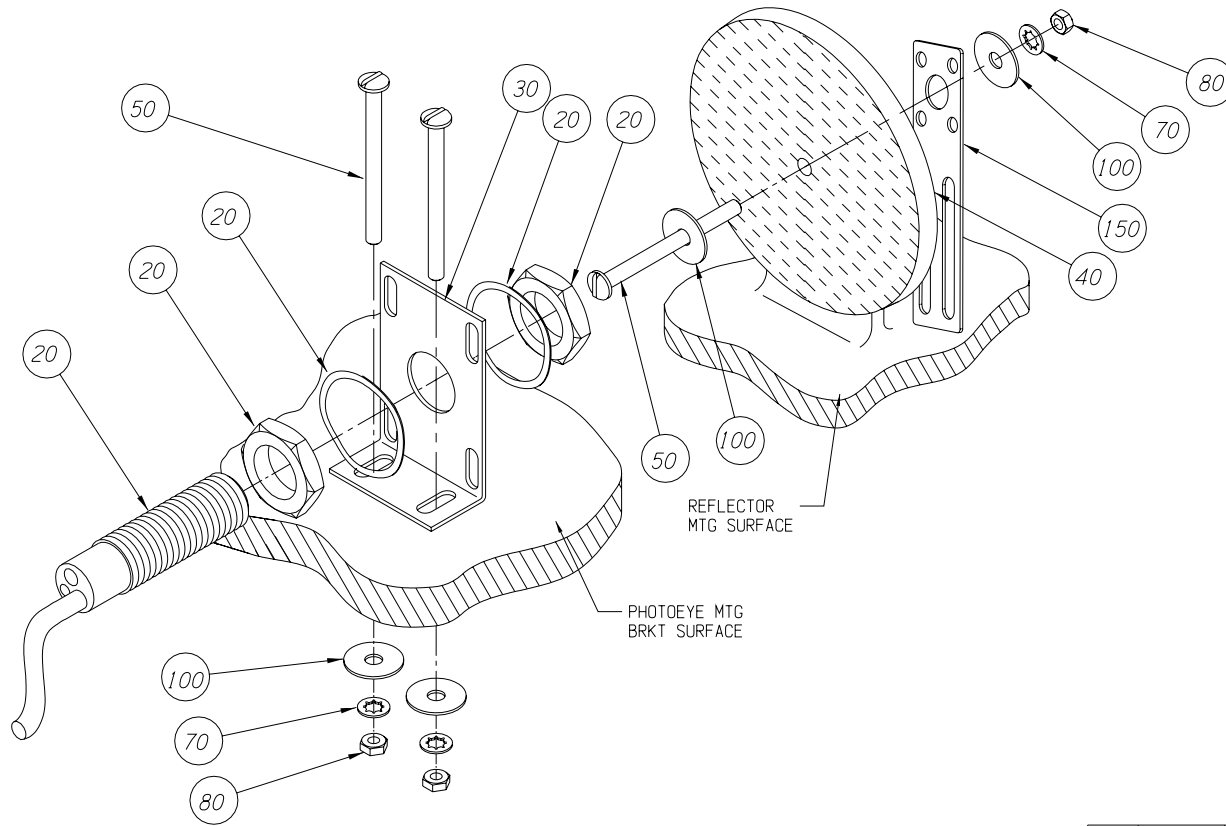

ITEM	QTY	PART NO	DESCRIPTION
150	1	1000012324	BRACKET, STANDARD PHOTOEYE MOUNTING
110	1	1000012429	BAG, 5X7X.002, POLY (NOT SHOWN)
100	4	1000022111	WASHER, #6 LARGE OD, FLAT, ...
90	1	1000019379	LABEL, WIRE 2 IN X .38 IN (NOT SHOWN)
80	3	1000018459	NUT, #6-32 HEX
70	3	1000016776	LOCKWASHER, #6 INTERNAL TOOTH
60	1	1000012302	BAG, 10X12X.002, POLY (NOT SHOWN)
50	3	1000009740	SCREW, 6-32, 2", PHILLIPS, MACHINE, PAN HEAD, STEEL, ZINC
40	1	1000013792	REFLECTOR, 3 INCH
30	1	1000011711	BRACKET, SMALL SCANNER PHOTOEYE MOUNTING
20	1	1000002103	ASSEMBLY, LARGE SCANNER SINGLE PHOTOEYE 12 FT SHIELDED CABLE W/AMPHENOL CONNECTOR
10	1	1000001504	DIAGRAM, POLARIZED PHOTOEYE MOUNTING

PART NO. 1000020538

THIS IS NOT A CONTROLLED COPY UNLESS STAMPED "CONTROLLED COPY" IN RED
 THIS DOCUMENT IS PROVIDED FOR A SPECIFIC PURPOSE AND THE DISCLOSED INFORMATION REMAINS OUR PROPERTY. IT MAY NOT BE DISCLOSED, COPIED, OR REPRODUCED, EXCEPT FOR THE SPECIFIC PURPOSE, WITHOUT ACCU-SORT'S PRIOR APPROVAL. THIS NOTICE MUST APPEAR ON ANY COPY OR REPRODUCTION OF THIS DOCUMENT.
 ©2004, ACCU-SORT SYSTEMS, INC.

UNLESS OTHERWISE SPECIFIED:
 ALL DIMENSIONS ARE IN INCHES
 ALL ANGLES ARE 90°
 ALL C-SINKS ARE 82°
 ALL BEND RELIEFS TO SUIT
 TOLERANCES:
 INCH (METRIC) ANGULAR
 .X1-.1000 (.X2,500) X±1.00"
 .XX1-.0200 (.XX4,500) .X±0.10"
 .XXX1-.0050 (.XXX4,130) .XX±0.01"
 .XXXX1-.0005 (.XXXX,013) .XX±0.01"
 FRACTIONS ±1/4
 FT., IN ±1/2
 REMOVE SHARP EDGES AND BURRS

DRAWN TJB DATE 11.10.05
 CHKD DATE
 ENGR TJB DATE 11.10.05
 DEPT. MECH ENG
 E- N/A
 CUSTOMER N/A
 CONTRACT # N/A

ACCU-SORT® SYSTEMS, inc.
 TELFORD, PA 18969 USA
 ASSEMBLY, POLARIZED PHOTOEYE MOUNTING DIAGRAM
 SIZE C CAGE CODE 53830 DWG. NO. 24130
 SCALE NONE CAD SYS. CADKEY SHEET 1 OF 2

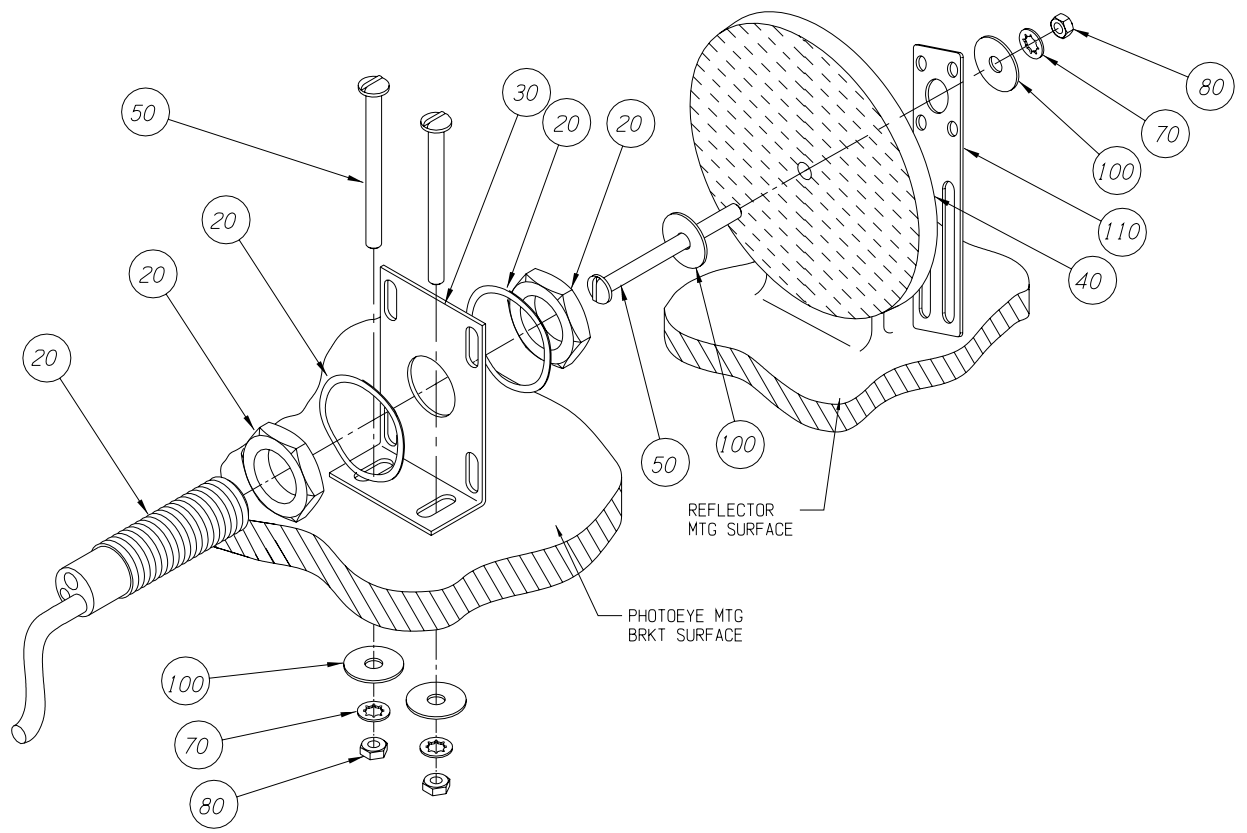

ITEM	QTY/ASSY	PART NO	DESCRIPTION
110	1	1000002324	BRACKET, STANDARD PHOTOEYE MOUNTING
100	4	1000022111	WASHER, #6 LARGE OD, FLAT, ...
90	1	1000019379	LABEL, WIRE 2 IN X .381 IN (NOT SHOWN)
80	3	1000018459	NUT, #6-32 HEX
70	3	1000016776	LOCKWASHER, #6 INTERNAL TOOTH
60	1	1000012384	BAG, 3X5X.002, POLY (NOT SHOWN)
50	3	1000009740	SCREW, 6-32, 2", PHILLIPS, MACHINE, PAN HEAD, STEEL, ZINC
40	1	1000013792	REFLECTOR, 3 INCH
30	1	1000011711	BRACKET, SMALL SCANNER PHOTOEYE MOUNTING
20	1	1000013425	PHOTOEYE, POLARIZED 6FT SHIELDED CABLE W/9-PIN DIN
10	1	1000001504	DIAGRAM, POLARIZED PHOTOEYE MOUNTING

PART NO. 1000020527		ITEM QTY/ASSY PART NO DESCRIPTION																
<p>THIS IS NOT A CONTROLLED COPY UNLESS STAMPED "CONTROLLED COPY" IN RED</p> <p>THIS DOCUMENT IS PROVIDED FOR A SPECIFIC PURPOSE AND THE DISCLOSED INFORMATION REMAINS OUR PROPERTY. IT MAY NOT BE DISCLOSED, COPIED, OR REPRODUCED, EXCEPT FOR THE SPECIFIC PURPOSE, WITHOUT ACCU-SORT'S PRIOR APPROVAL. THIS NOTICE MUST APPEAR ON ANY COPY OR REPRODUCTION OF THIS DOCUMENT.</p> <p>©2004, ACCU-SORT SYSTEMS, INC.</p>		<p>UNLESS OTHERWISE SPECIFIED: ALL DIMENSIONS ARE IN INCHES ALL ANGLES ARE 90° ALL C-SINKS ARE 82° ALL BEND RELIEFS TO SUIT</p> <p>TOLERANCES:</p> <table border="1"> <tr> <th>INCH</th> <th>(METRIC)</th> <th>ANGULAR</th> </tr> <tr> <td>.xx-1.000</td> <td>[x]±2,500</td> <td>x±1.00°</td> </tr> <tr> <td>.xxx-0.020</td> <td>[.x]±0,500</td> <td>.x±0.10°</td> </tr> <tr> <td>.xxxx-0.005</td> <td>[.xx]±0,130</td> <td>.xx±0.01°</td> </tr> <tr> <td>.xxxxx-0.001</td> <td>[.xxx]±0,013</td> <td></td> </tr> </table> <p>FRACTIONS 1/4 1/2 3/4 FT., IN REMOVE SHARP EDGES AND BURRS</p>		INCH	(METRIC)	ANGULAR	.xx-1.000	[x]±2,500	x±1.00°	.xxx-0.020	[.x]±0,500	.x±0.10°	.xxxx-0.005	[.xx]±0,130	.xx±0.01°	.xxxxx-0.001	[.xxx]±0,013	
		INCH	(METRIC)	ANGULAR														
.xx-1.000	[x]±2,500	x±1.00°																
.xxx-0.020	[.x]±0,500	.x±0.10°																
.xxxx-0.005	[.xx]±0,130	.xx±0.01°																
.xxxxx-0.001	[.xxx]±0,013																	
<p>DRAWN TJB DATE 11.10.05</p> <p>CHKD DATE</p> <p>ENGR TJB DATE 11.10.05</p> <p>DEPT. MECH ENG</p> <p>E- N/A</p> <p>CUSTOMER N/A</p> <p>CONTRACT # N/A</p>		<p>ACCU-SORT® SYSTEMS, inc. TELFORD, PA 18969 USA</p> <p>ASSEMBLY, POLARIZED PHOTOEYE MOUNTING DIAGRAM</p> <p>SIZE C CAGE CODE 53830 DWG. NO. 24130</p> <p>SCALE NONE CAD SYS. CADKEY SHEET 2 OF 2</p>																

NOTES:
 1) COMPONENTS LISTED IN ERP BILL OF MATERIALS (REF. # 0102974001)
 2) ATTACH ONE END OF THE 3 FT. GROUND WIRE TO ITEM 20 USING #6-32 CAP SCREW AND #6-32 HEX NUT AS SHOWN.

REVISION			
REV	CHANGE	BY	DATE
05	09-402	AS	10/28/09

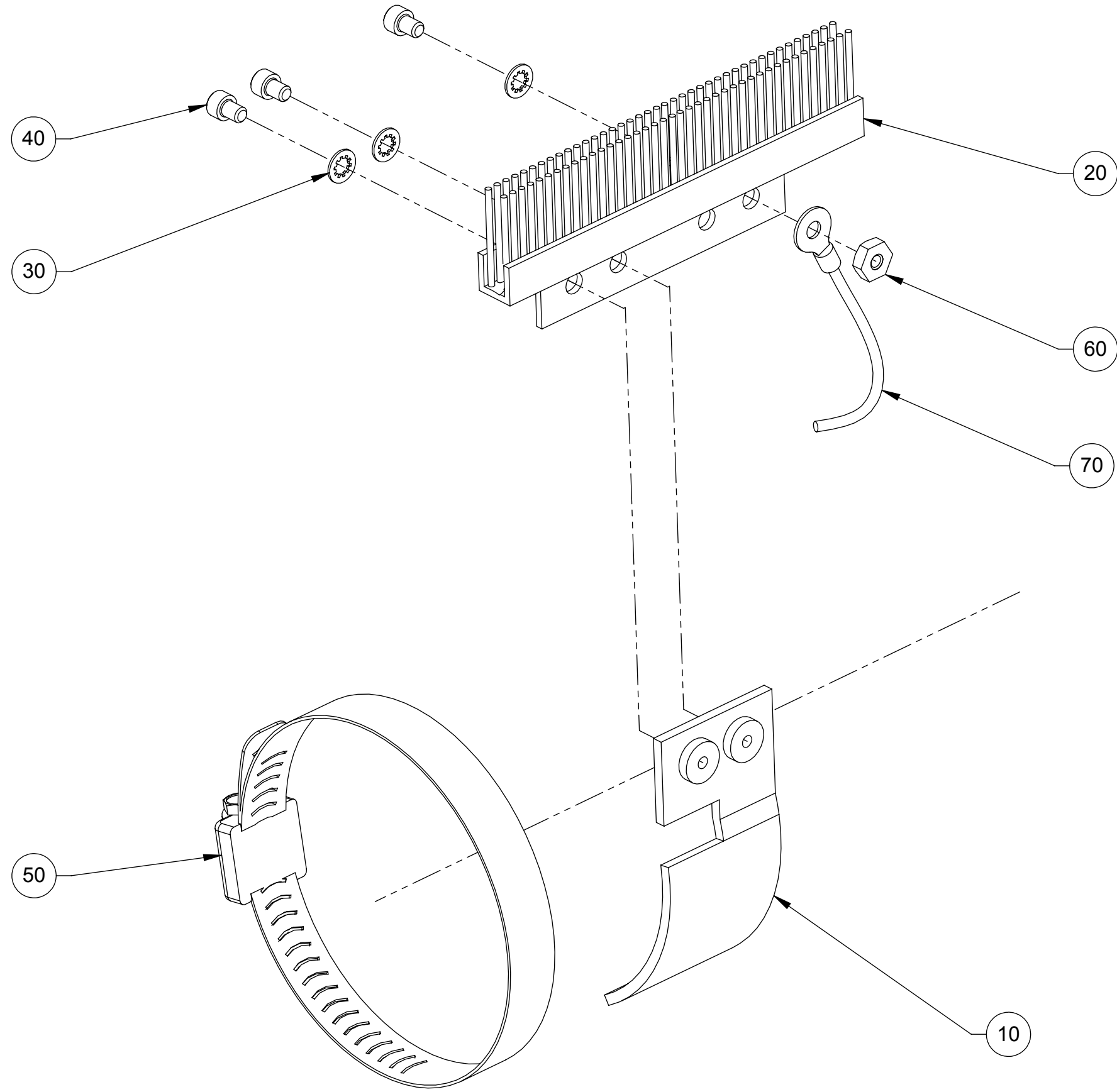

SHEET 2
 SHEET 2
 NOT SHOWN

ITEM	QTY.	PART NO.	DESCRIPTION
100	1	1000066953	FERRITE, STAR-RING RINGCORE WITH PLASTIC CASE, BLACK SNAP, CABLE DIA MAX 27MM, ROHS EU
90	1	0102974000	DIAGRAM, INSTALLATION, ANTI-STATIC BRUSH ASSEMBLY
80	1	1000009725	SCREW, 6-32, 1, HEX CAP, SOCKET HEAD, STEEL, BLACK OXIDE
70	1	1000053263	ASSEMBLY, GROUND-WIRE, ANTI-STATIC BRUSH
60	2	1000018459	NUT, #6-32 HEX
50	1	1000050624	CLAMP, 3.5 IN HOSE
40	3	1000009683	SCREW, 6-32, 1/4, HEX CAP, SOCKET HEAD, STAINLESS
30	4	1000016777	LOCKWASHER, #6 INTERNAL TOOTH, STAINLESS
20	1	0102973001	BRUSH, TACHOMETER, ANTI-STATIC
10	1	0102972001	BRACKET, TACHOMETER BRUSH, ANTI-STATIC

PART NO. 0102974001

THIS IS NOT A CONTROLLED COPY UNLESS STAMPED "CONTROLLED COPY" IN RED
 THIS DOCUMENT IS PROVIDED FOR A SPECIFIC PURPOSE AND THE DISCLOSED INFORMATION REMAINS OUR PROPERTY. IT MAY NOT BE DISCLOSED, COPIED, OR REPRODUCED, EXCEPT FOR THE SPECIFIC PURPOSE, WITHOUT ACCU-SORT'S PRIOR APPROVAL. THIS NOTICE MUST APPEAR ON ANY COPY OR REPRODUCTION OF THIS DOCUMENT.
 © 2007, ACCU-SORT SYSTEMS, INC.

UNLESS OTHERWISE SPECIFIED DIMENSIONS ARE IN INCHES [MILLIMETERS]
 ALL ANGLES ARE 90°
 ALL C-CINKS ARE 82° INCLUDED ANGLE
 ALL BEND RELIEFS TO SUIT
 TOLERANCES:

INCH	[METRIC]	ANGULAR
.X±.1000	[X±2.500]	X±1.00°
.XX±.0200	[X±0.500]	X±0.10°
.XXX±.0050	[X±0.130]	XX±0.01°
.XXXX±.0005	[XXX±0.013]	

 FRACTIONS ±1/4
 FT., IN ±1"
 REMOVE SHARP EDGES AND BURRS

DRAWN AS DATE 08/26/09
 CHKD XXX DATE XX.XX.XX
 ENGR DJK DATE 04/25/01
 DEPT. MECH ENG
 E- N/A
 CUSTOMER N/A
 CONTRACT # N/A

 ACCU-SORT® SYSTEMS, inc.
 TELFORD, PA 18969 USA

ASSEMBLY, BRUSH, ANTI-STATIC

SIZE C	CAGE CODE 53830	DWG. NO. 102974
SCALE NONE	CAD SYS. SOLIDWORKS	SHEET 1 OF 2

- NOTES:
 1) ATTACH OPPOSITE END OF GROUND WIRE TO CONVEYOR ESTABLISHING EARTH GROUND USING (1) #6-32 SCREW, (1) #6 HEX NUT, AND (1) #6 LOCKWASHER SUPPLIED.
 2) INSTALL BRUSH TOUCHING CONVEYOR NO MORE THAN 1/8" FROM BELT.
 3) CABLE TO WRAP AROUND FERRITE A MINIMUM OF 6 TIMES AS SHOWN.

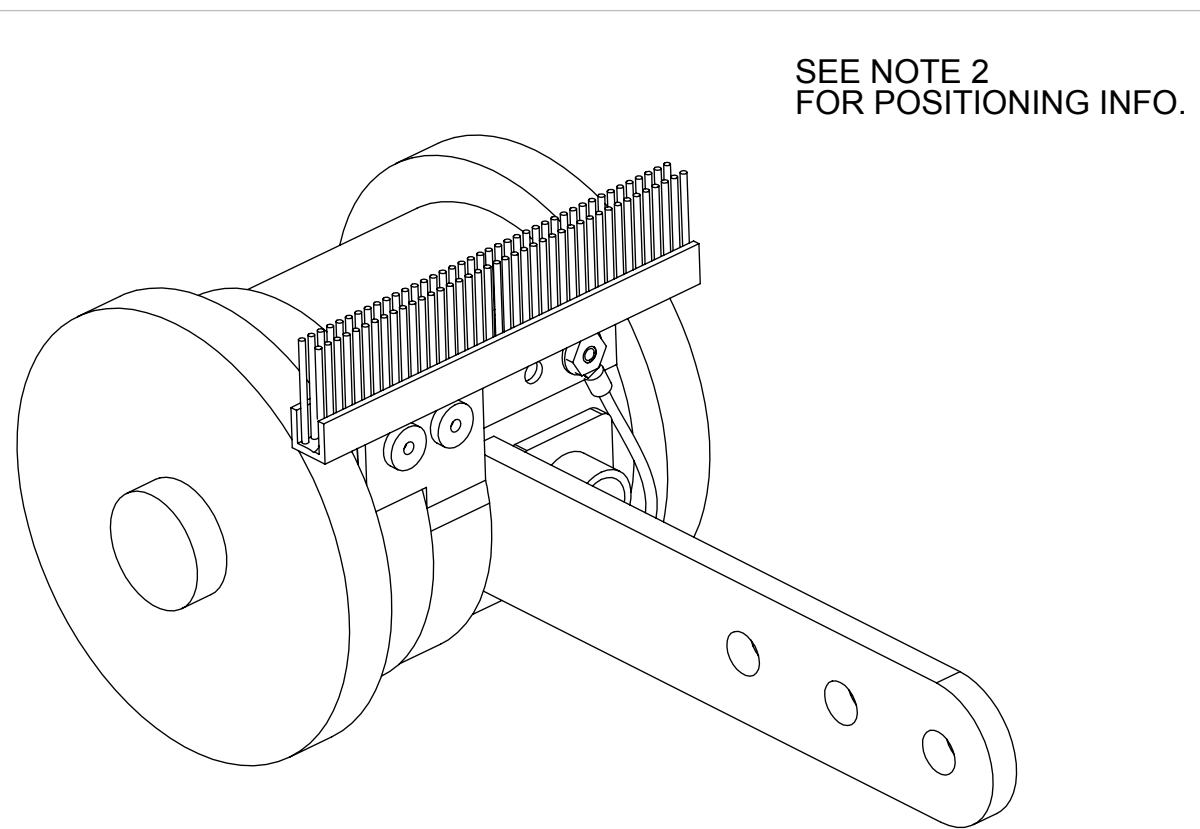
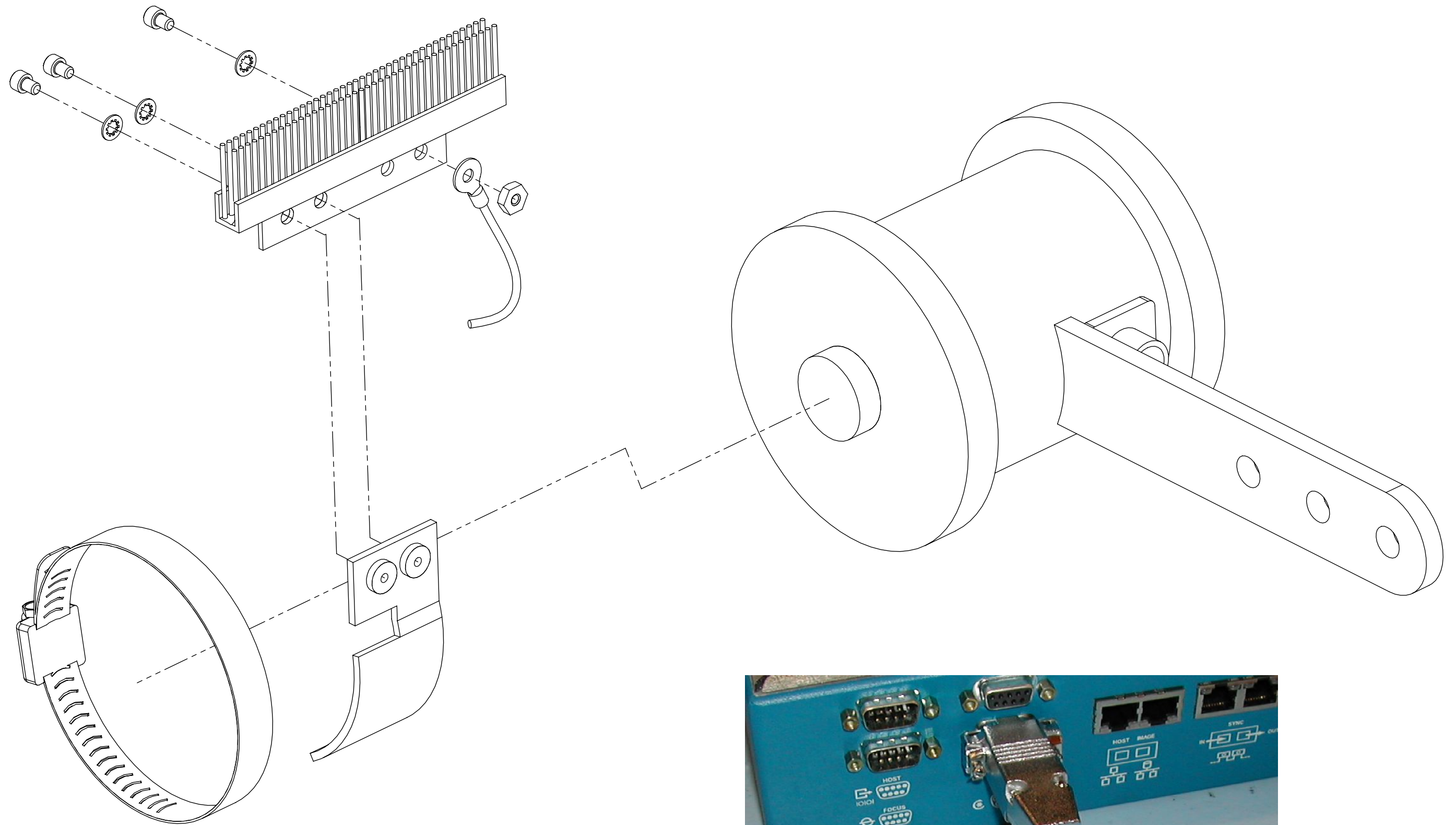

SEE NOTE 2 FOR POSITIONING INFO.

ASSEMBLED VIEW



FERRITE INSTALLATION AND LOCATION
SEE NOTE 3

PART NO. 0102974000

THIS IS NOT A CONTROLLED COPY UNLESS STAMPED "CONTROLLED COPY" IN RED
 THIS DOCUMENT IS PROVIDED FOR A SPECIFIC PURPOSE AND THE DISCLOSED INFORMATION REMAINS OUR PROPERTY. IT MAY NOT BE DISCLOSED, COPIED, OR REPRODUCED, EXCEPT FOR THE SPECIFIC PURPOSE, WITHOUT ACCU-SORT'S PRIOR APPROVAL. THIS NOTICE MUST APPEAR ON ANY COPY OR REPRODUCTION OF THIS DOCUMENT.
 © 2004, ACCU-SORT SYSTEMS, INC.

UNLESS OTHERWISE SPECIFIED DIMENSIONS ARE IN INCHES [MILLIMETERS]
 ALL ANGLES ARE 90°
 ALL C-CINKS ARE 82° INCLUDED ANGLE
 ALL BEND RELIEFS TO SUIT
 TOLERANCES:
 INCH [METRIC] ANGULAR
 .X±.1000 [X±2.500] X±1.00°
 .XX±.0200 [X±0.500] X±0.10°
 .XXX±.0050 [XX±0.130] XX±0.01°
 .XXXX±.0005 [XXX±0.013]
 FRACTIONS ±1/4
 FT., IN ±1"
 REMOVE SHARP EDGES AND BURRS

DRAWN	AS	DATE	08/26/09
CHKD	XXX	DATE	XX.XX.XX
ENGR	DJK	DATE	04/25/01
DEPT.	MECH ENG		
E-	N/A		
CUSTOMER	N/A		
CONTRACT #	N/A		

 ACCU-SORT [®] SYSTEMS, inc. TELFORD, PA 18969 USA		
ASSEMBLY, BRUSH, ANTI-STATIC INSTALLATION		
SIZE	CAGE CODE	DWG. NO.
C	53830	102974
SCALE	NONE	CAD SYS. SOLIDWORKS
SHEET		2 OF 2

REVISIONS			
REV		BY	DATE
3	ECO 12-40	JG	02/14/12

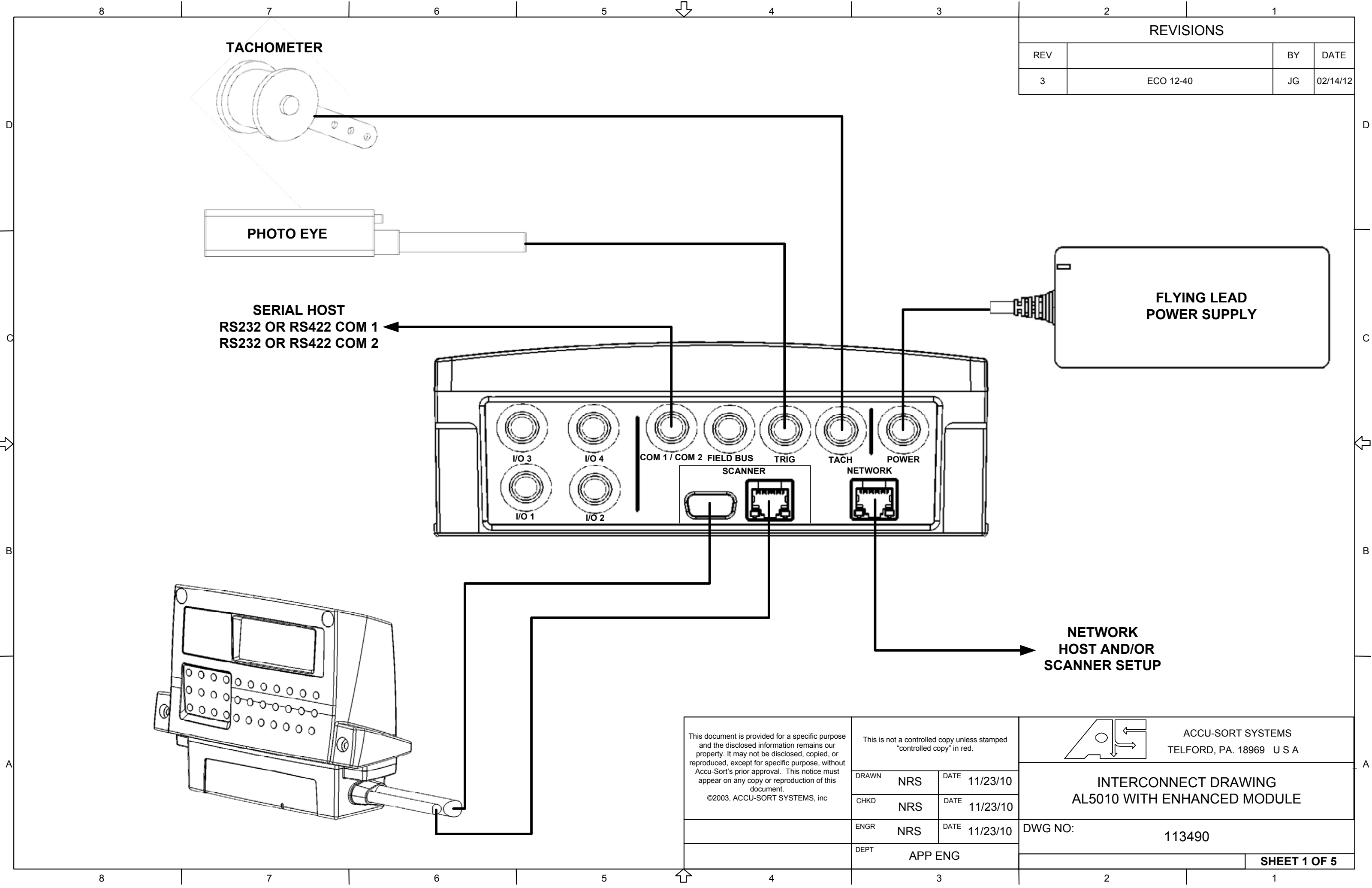

8 7 6 5 4 3 2 1

D

D

C

C

B

B

A

A

A

A

8 7 6 5 4 3 2 1

This document is provided for a specific purpose and the disclosed information remains our property. It may not be disclosed, copied, or reproduced, except for specific purpose, without Accu-Sort's prior approval. This notice must appear on any copy or reproduction of this document. ©2003, ACCU-SORT SYSTEMS, inc	This is not a controlled copy unless stamped "controlled copy" in red.			
	DRAWN	NRS	DATE	11/23/10
	CHKD	NRS	DATE	11/23/10
	ENGR	NRS	DATE	11/23/10
DEPT	APP ENG			

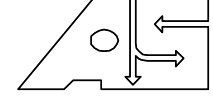
 ACCU-SORT SYSTEMS TELFORD, PA. 18969 U S A
DWG NO: 113490
SHEET 1 OF 5

REVISIONS			
REV		BY	DATE
3	ECO 12-40	JG	02/14/12

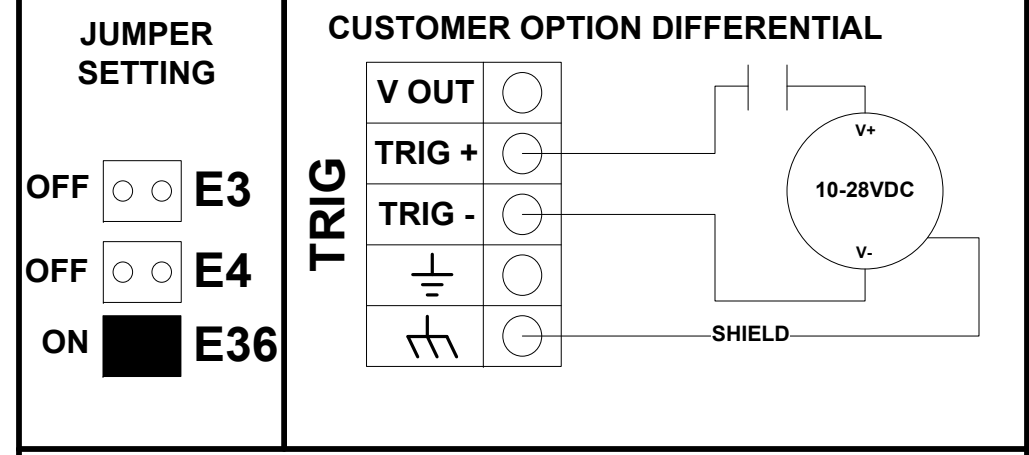
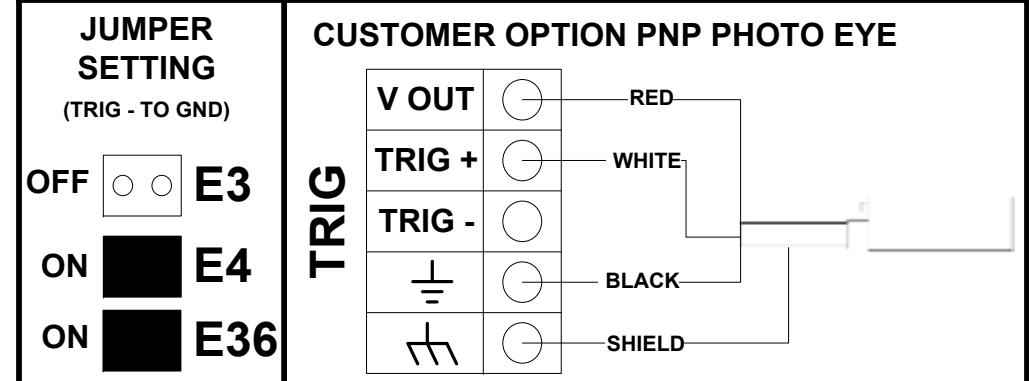
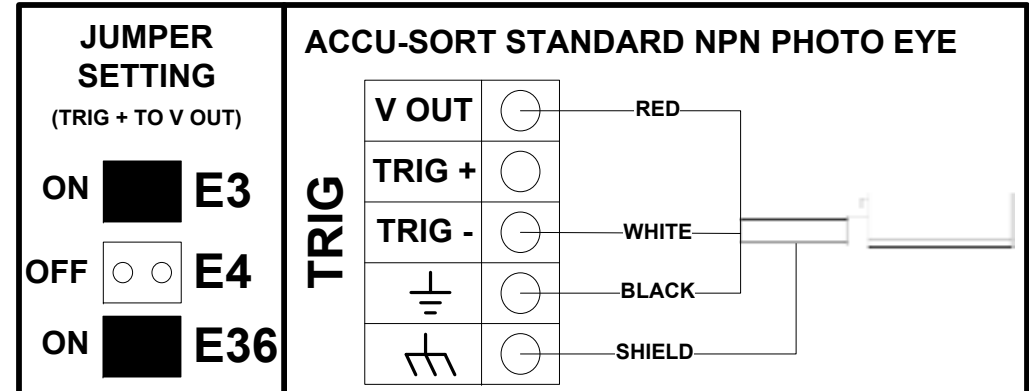

NOTE: REMOVE E36 TO INCREASE MINIMUM TRIGGER LEVEL TO APPROXIMATELY 7 VDC

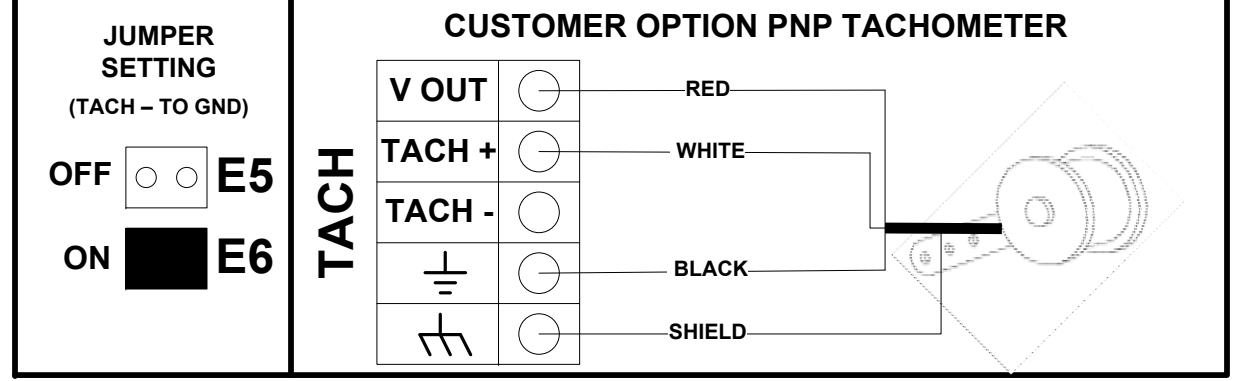
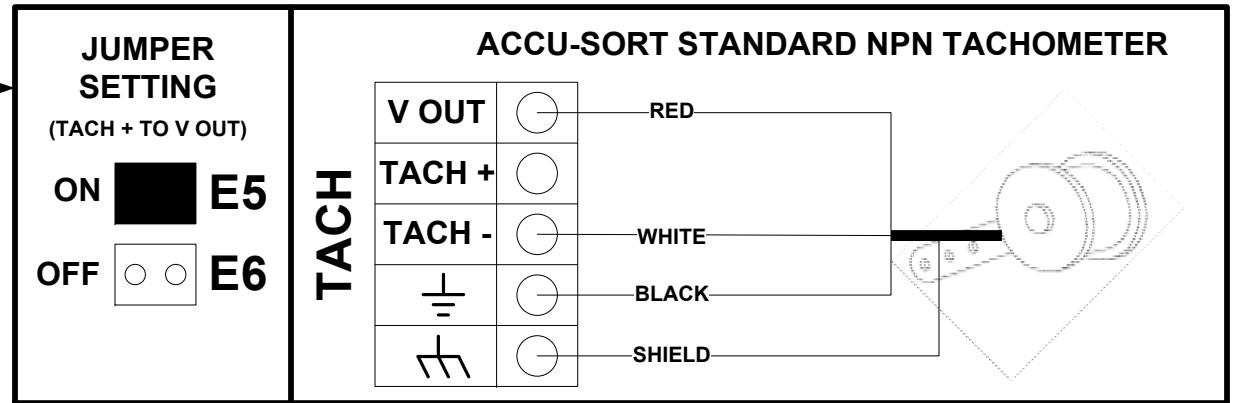
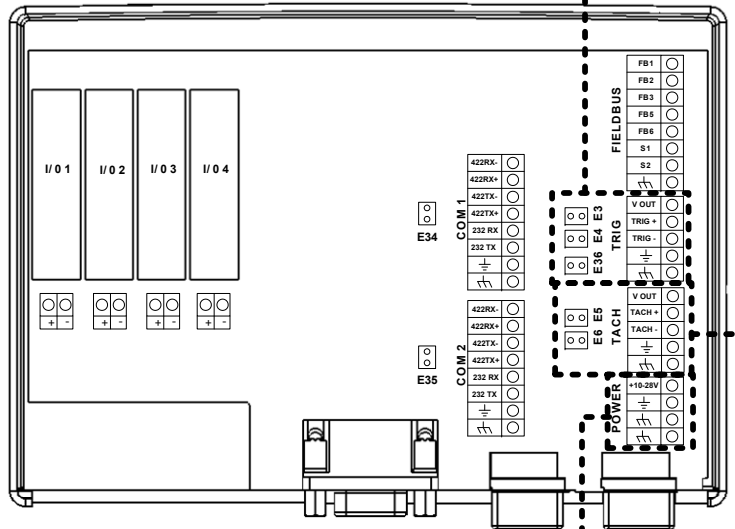
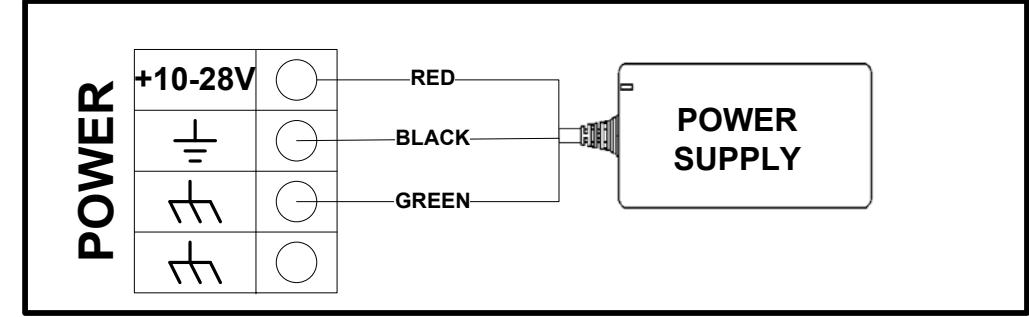

<p>This document is provided for a specific purpose and the disclosed information remains our property. It may not be disclosed, copied, or reproduced, except for specific purpose, without Accu-Sort's prior approval. This notice must appear on any copy or reproduction of this document.</p> <p>©2003, ACCU-SORT SYSTEMS, inc</p>	<p>This is not a controlled copy unless stamped "controlled copy" in red.</p>		<p>ACCU-SORT SYSTEMS TELFORD, PA. 18969 U S A</p>
	<p>DRAWN NRS</p>	<p>DATE 11/23/10</p>	
	<p>CHKD NRS</p>	<p>DATE 11/23/10</p>	<p>DWG NO: 113490</p>
	<p>ENGR NRS</p>	<p>DATE 11/23/10</p>	<p>DEPT APP ENG</p>

CONFIGURATION FOR START AND END TRIGGER PHOTO EYES

REVISIONS			
REV		BY	DATE
3	ECO 12-40	JG	02/14/12

ACCU-SORT STANDARD NPN PHOTO EYE
END TRIGGER

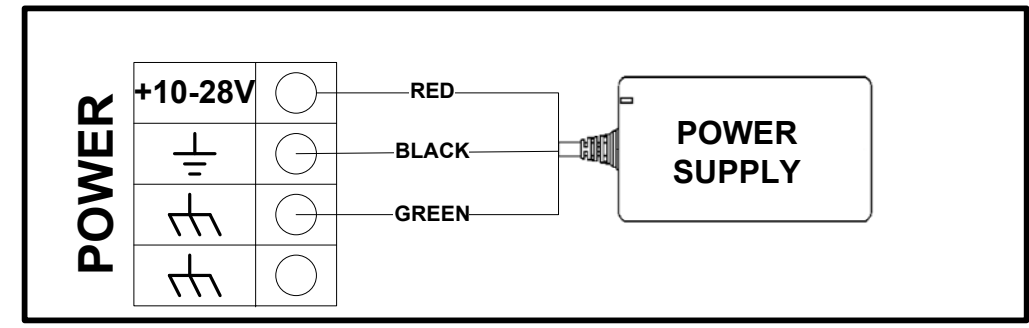
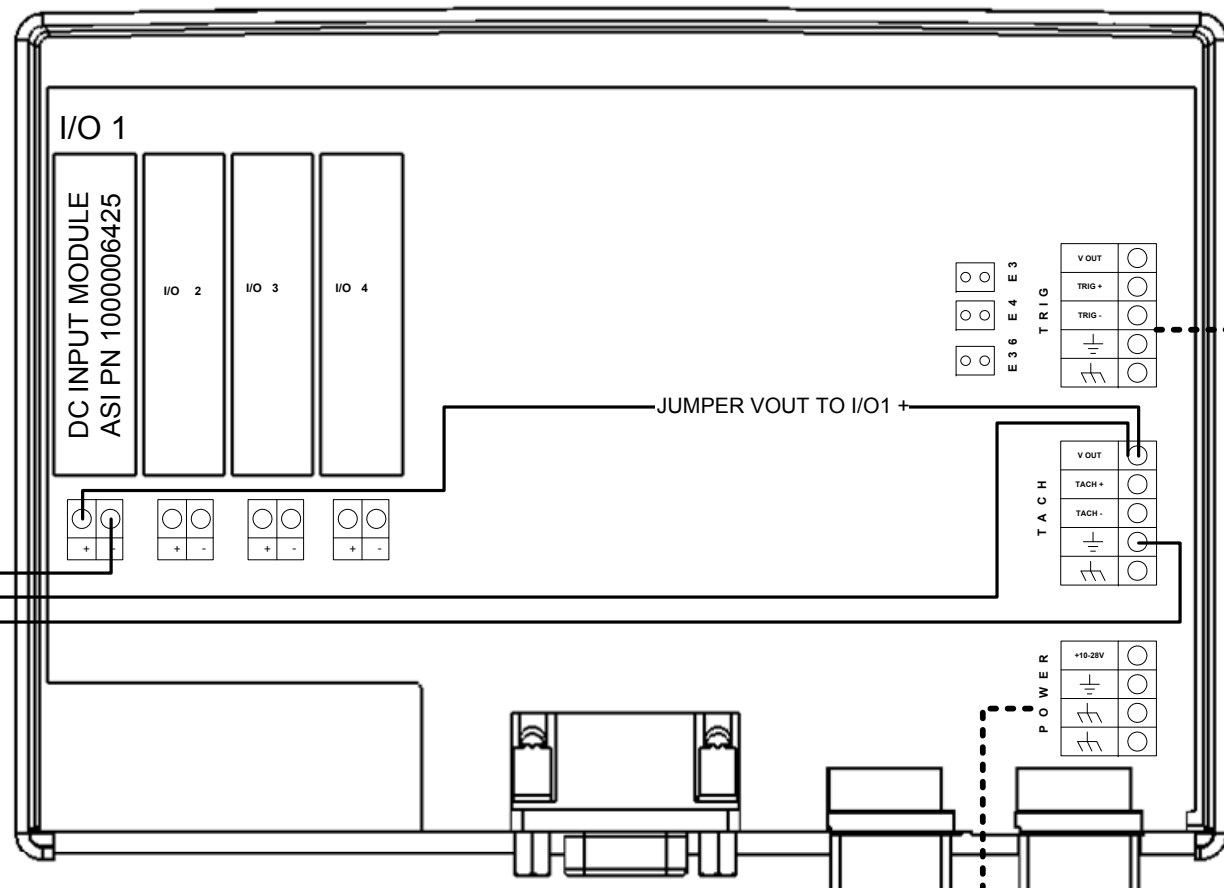
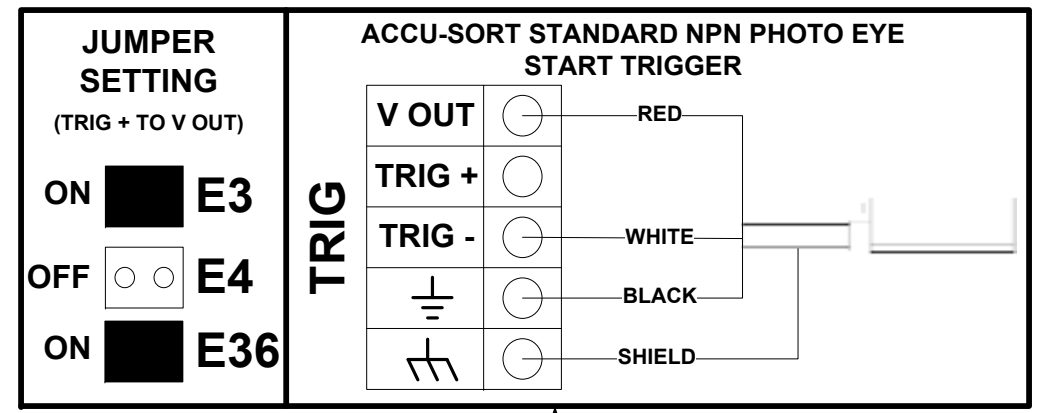
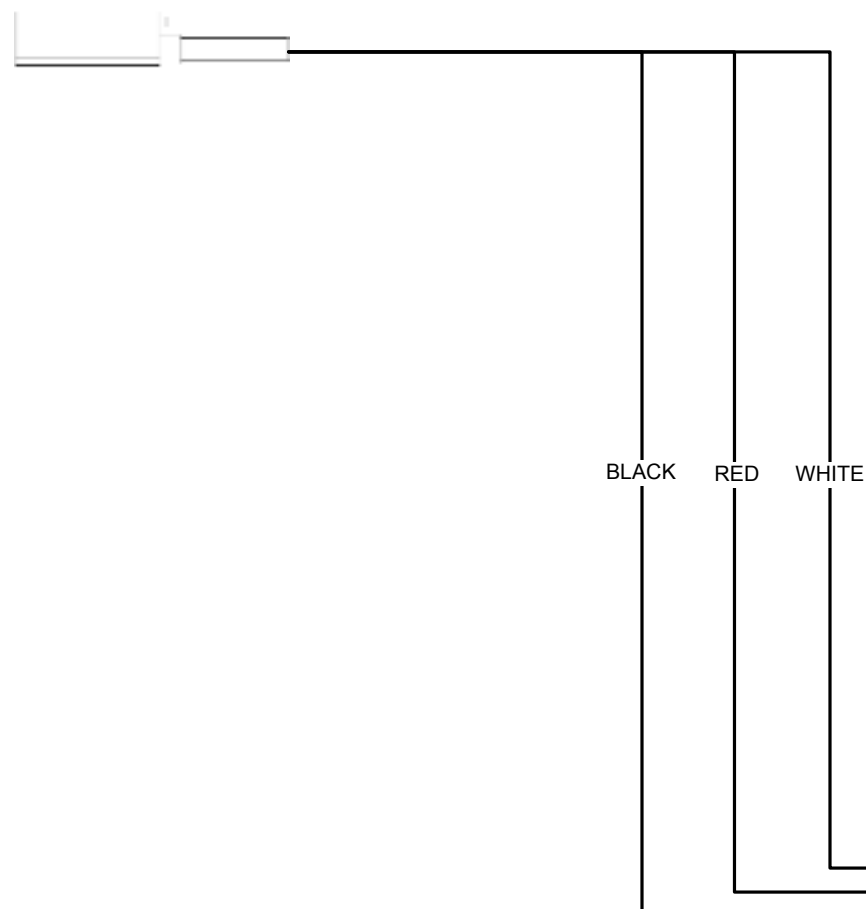

This document is provided for a specific purpose and the disclosed information remains our property. It may not be disclosed, copied, or reproduced, except for specific purpose, without Accu-Sort's prior approval. This notice must appear on any copy or reproduction of this document. ©2003, ACCU-SORT SYSTEMS, inc	This is not a controlled copy unless stamped "controlled copy" in red.		ACCU-SORT SYSTEMS TELFORD, PA. 18969 U S A	
	DRAWN	NRS		DATE
	CHKD	NRS	DATE	11/23/10
	ENGR	NRS	DATE	11/23/10
DEPT	APP ENG		DWG NO:	113490
			SHEET 3 OF 5	

CONFIGURATION FOR COMPUTED TACH PHOTO EYE AND TRIGGER PHOTO EYE

REVISIONS			
REV		BY	DATE
3	ECO 12-40	JG	02/14/12

ACCU-SORT STANDARD NPN PHOTO EYE TRIGGER

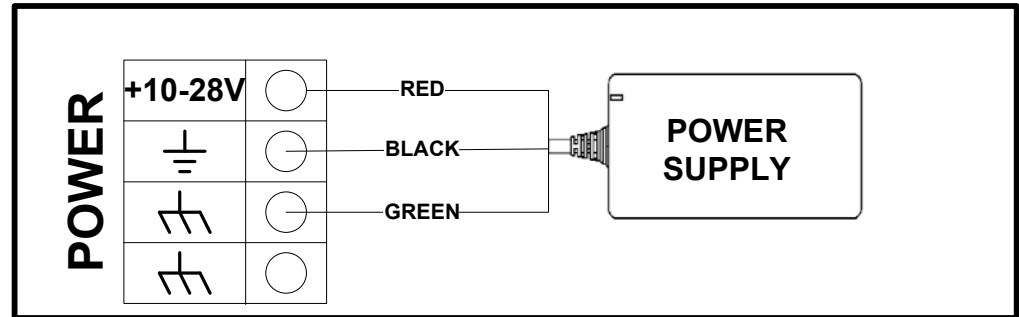
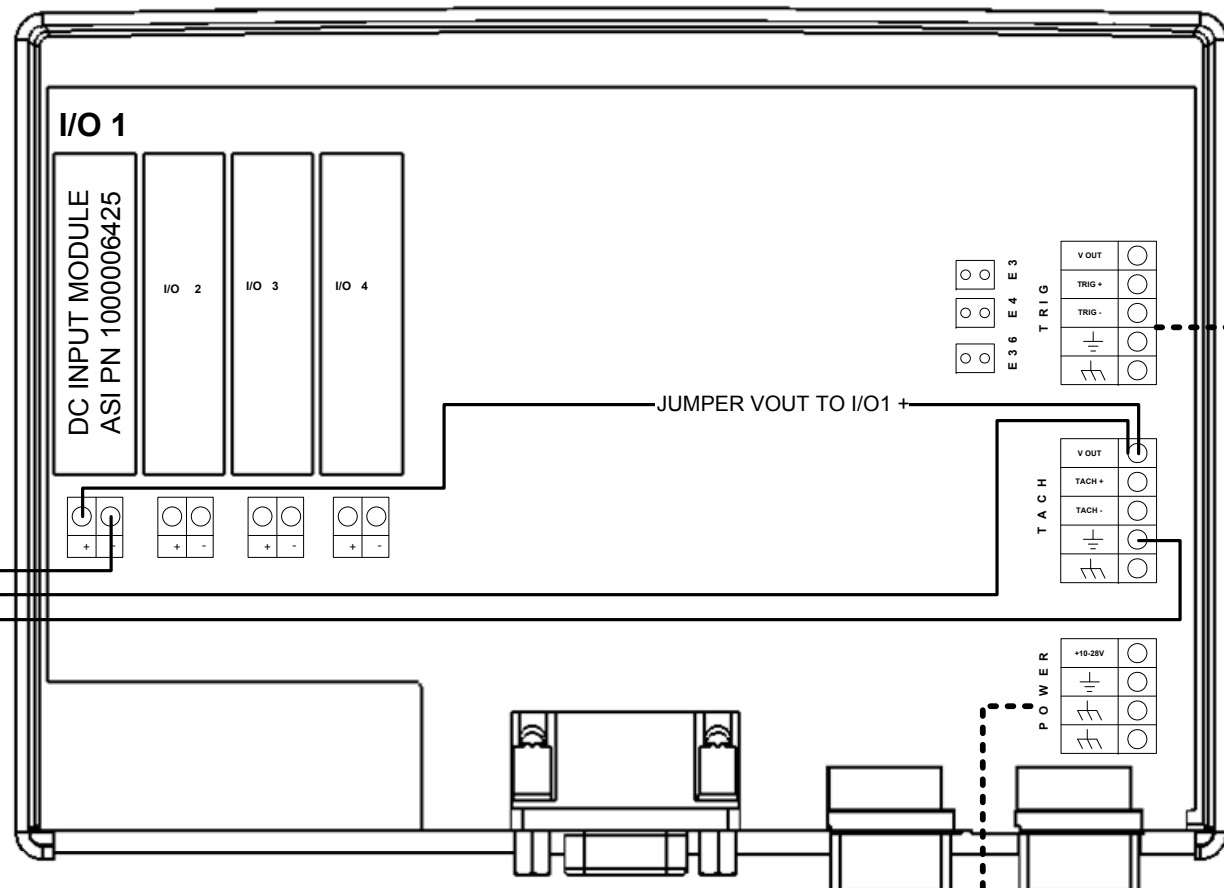
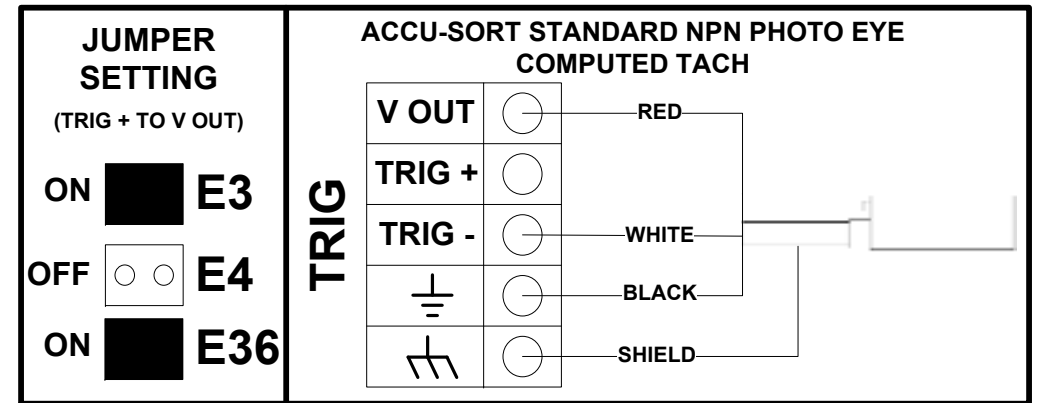
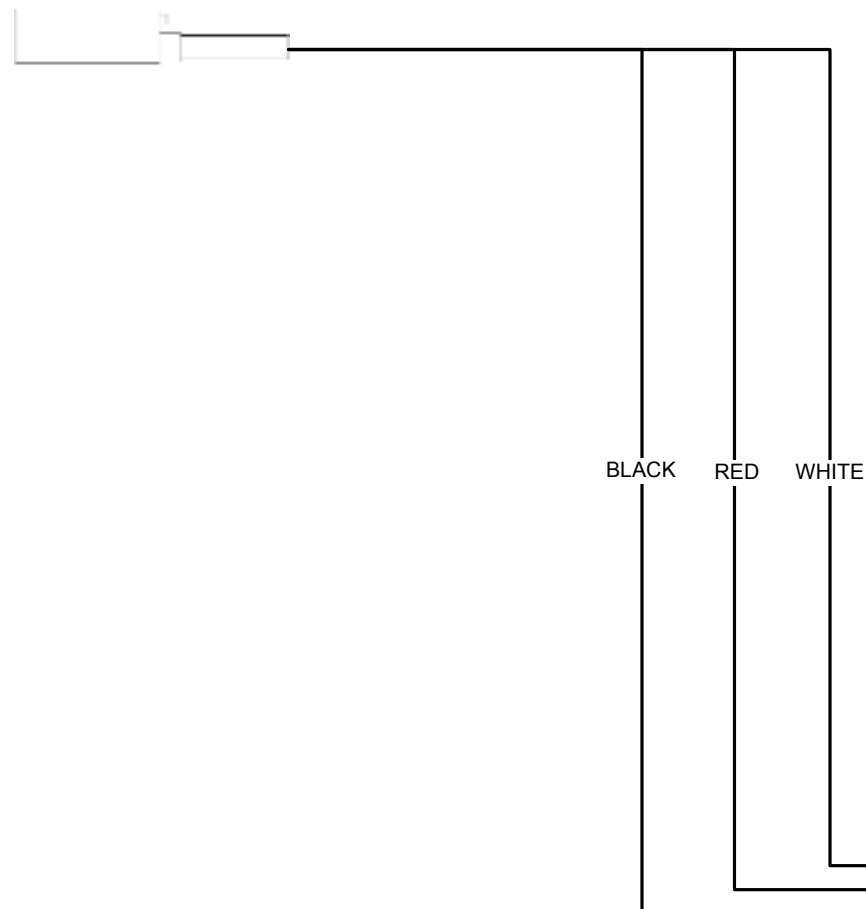

<p>This document is provided for a specific purpose and the disclosed information remains our property. It may not be disclosed, copied, or reproduced, except for specific purpose, without Accu-Sort's prior approval. This notice must appear on any copy or reproduction of this document.</p> <p>©2003, ACCU-SORT SYSTEMS, inc</p>	<p>This is not a controlled copy unless stamped "controlled copy" in red.</p>		<p>ACCU-SORT SYSTEMS TELFORD, PA. 18969 U S A</p>	
	DRAWN	NRS		DATE
	CHKD	NRS	DATE	11/23/10
	ENGR	NRS	DATE	11/23/10
DEPT	APP ENG		DWG NO:	113490
			SHEET 4 OF 5	

REVISIONS			
REV		BY	DATE
3	ECO 12-40	JG	02/14/12

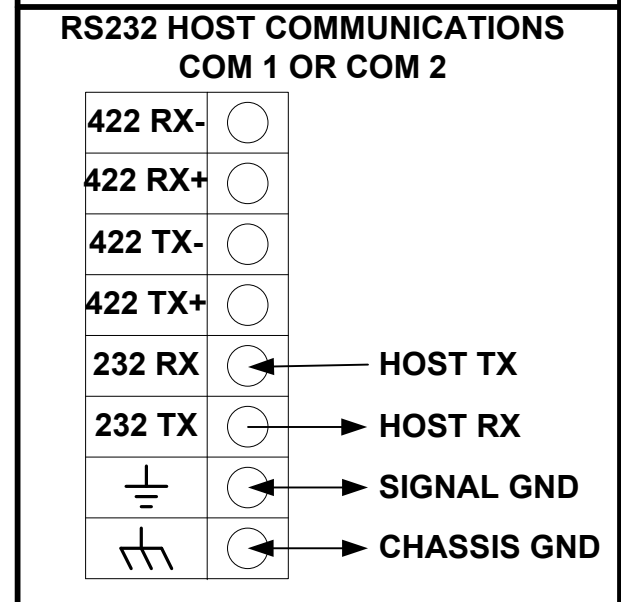
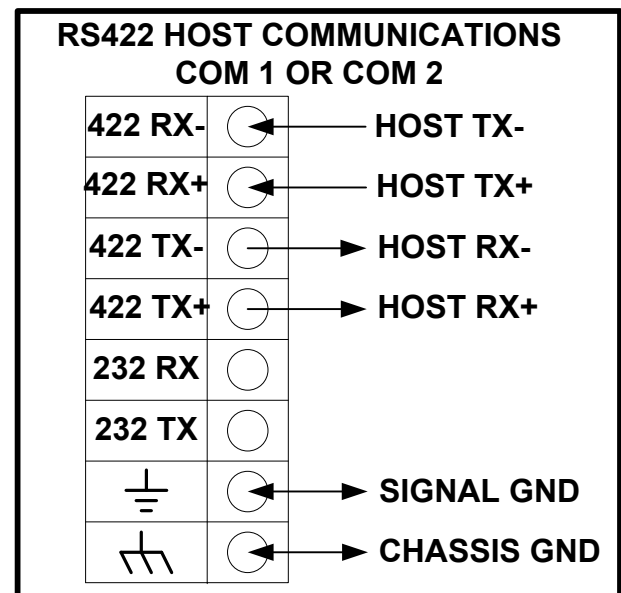

NOTE: RECOMMEND CABLE TYPE ALPHA 5473C OR EQUIVALENT

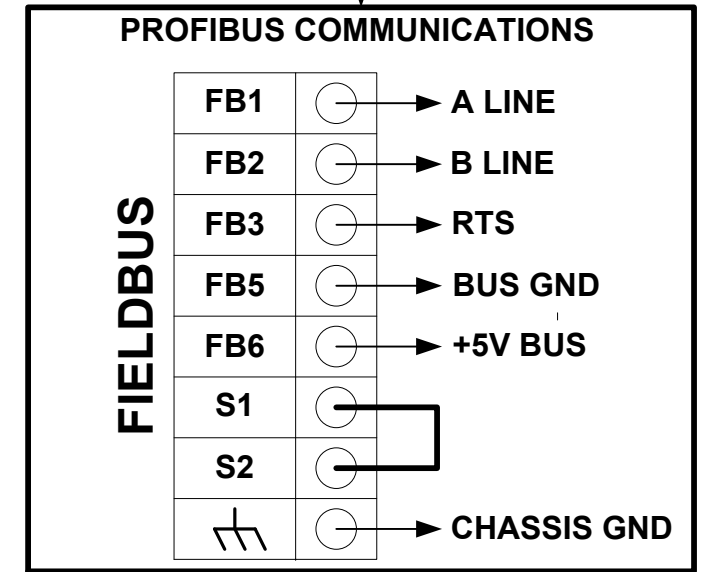
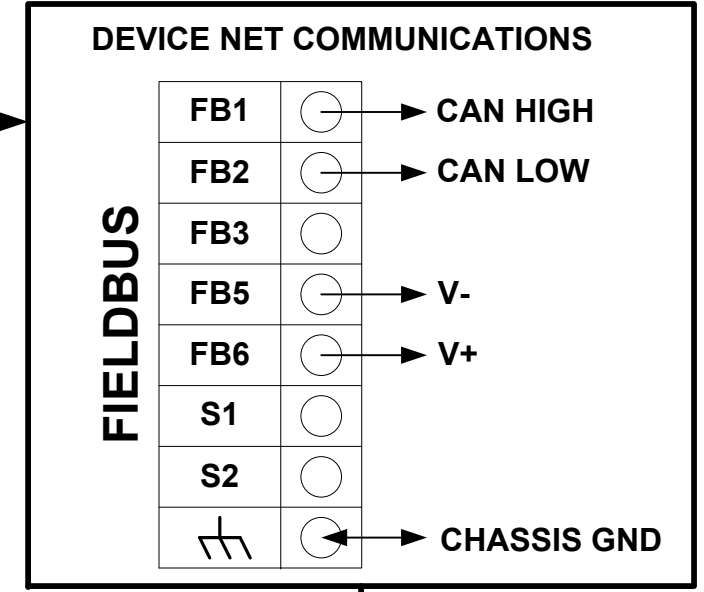
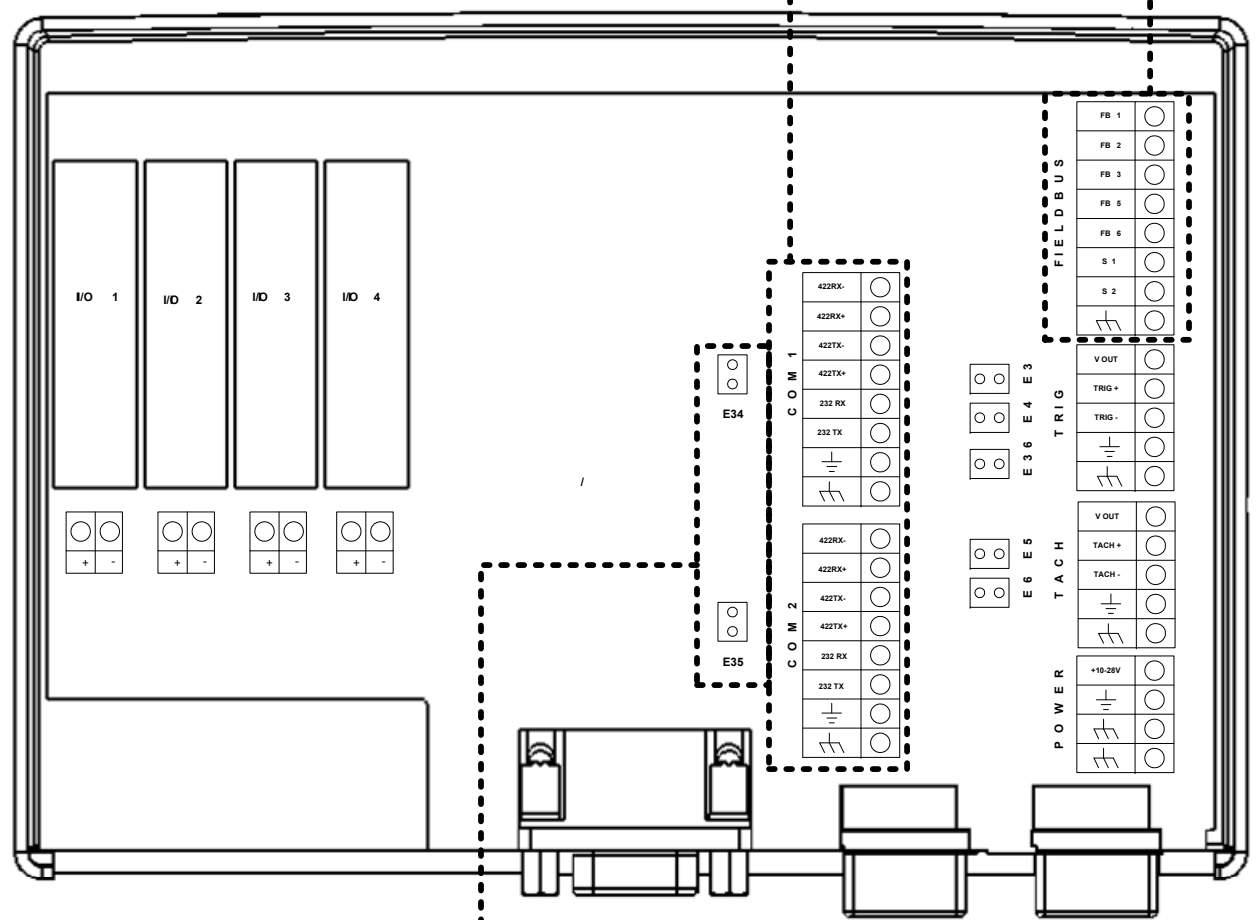
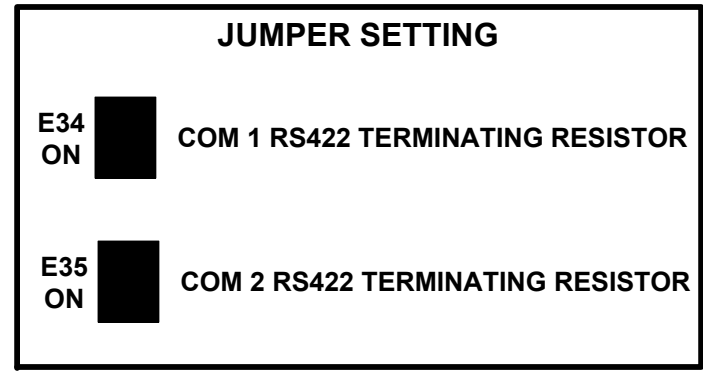

This document is provided for a specific purpose and the disclosed information remains our property. It may not be disclosed, copied, or reproduced, except for specific purpose, without Accu-Sort's prior approval. This notice must appear on any copy or reproduction of this document.

©2003, ACCU-SORT SYSTEMS, inc

DRAWN		NRS	DATE	11/23/10
CHKD		NRS	DATE	11/23/10
ENGR		NRS	DATE	11/23/10
DEPT		APP ENG		

ACCU-SORT SYSTEMS
TELFORD, PA. 18969 U S A

**INTERCONNECT DRAWING
AL5010 WITH ENHANCED MODULE**

DWG NO: 113490

SHEET 5 OF 5

REVISIONS			
REV		BY	DATE
1	INITIAL RELEASE	NRS	11/23/10

Controller-Client configuration using Enhanced Interface Module for the controller and the Basic Interface Module for the client. Refer to drawings 113490 INTERCONNECT DRAWING, AL5010 WITH ENHANCED MODULE and 113491 INTERCONNECT DRAWING, AL5010 WITH BASIC MODULE for component wiring directions.

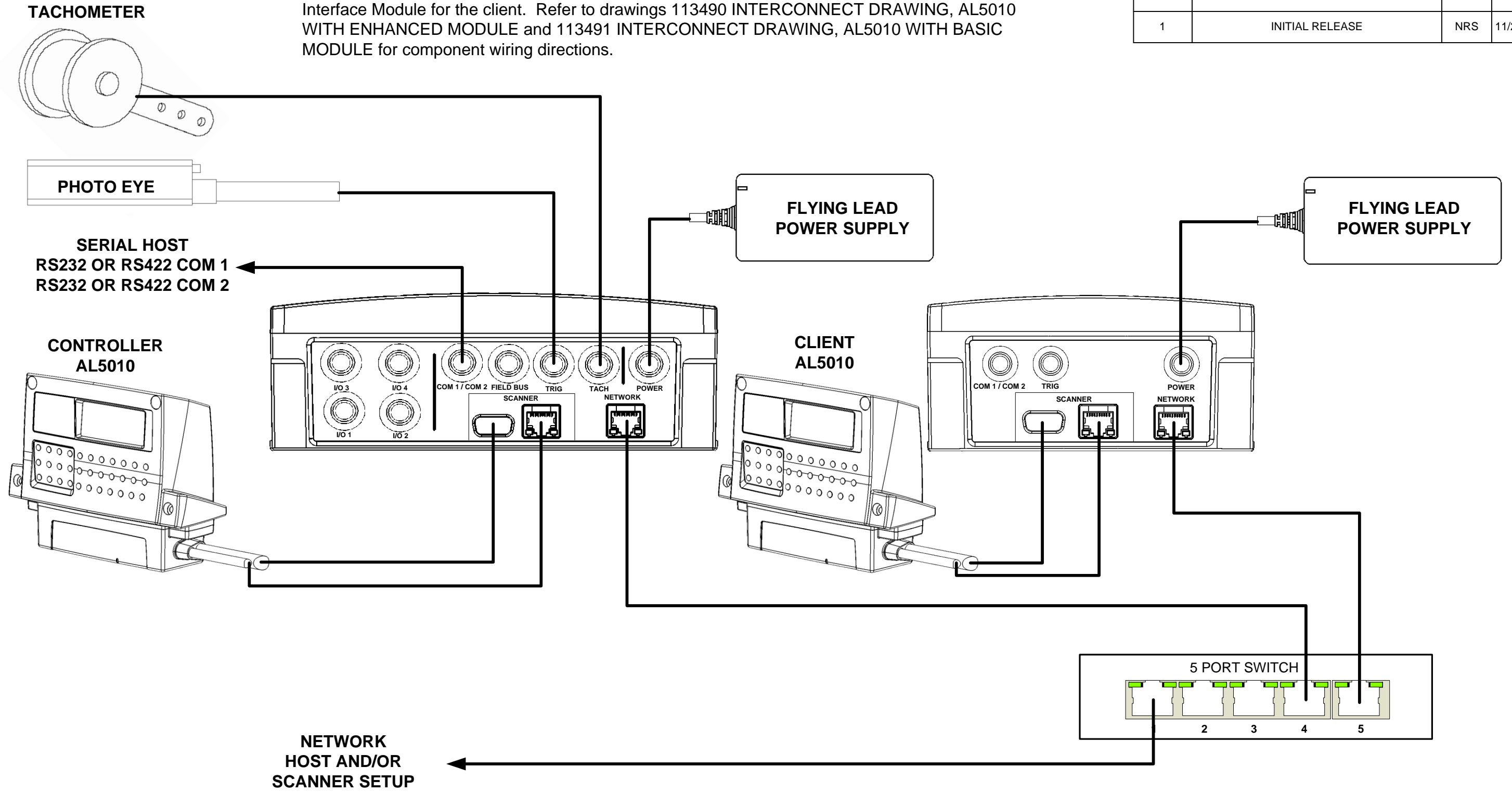

This document is provided for a specific purpose and the disclosed information remains our property. It may not be disclosed, copied, or reproduced, except for specific purpose, without Accu-Sort's prior approval. This notice must appear on any copy or reproduction of this document.
©2003, ACCU-SORT SYSTEMS, inc

This is not a controlled copy unless stamped "controlled copy" in red.			
DRAWN	NRS	DATE	11/23/10
CHKD	NRS	DATE	11/23/10
ENGR	NRS	DATE	11/23/10
DEPT	APP ENG		

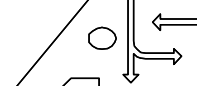
	ACCU-SORT SYSTEMS TELFORD, PA. 18969 U S A
	INTERCONNECT DRAWING AL5010 CONTROLLER CLIENT
DWG NO:	113492
SHEET 1 OF 2	

REVISIONS			
REV		BY	DATE
1	INITIAL RELEASE	NRS	11/23/10

Controller-Client configuration using Enhanced Interface Module for the controller and direct power connection on the client. Refer to drawings 113490 INTERCONNECT DRAWING, AL5010 WITH ENHANCED MODULE for component wiring directions.

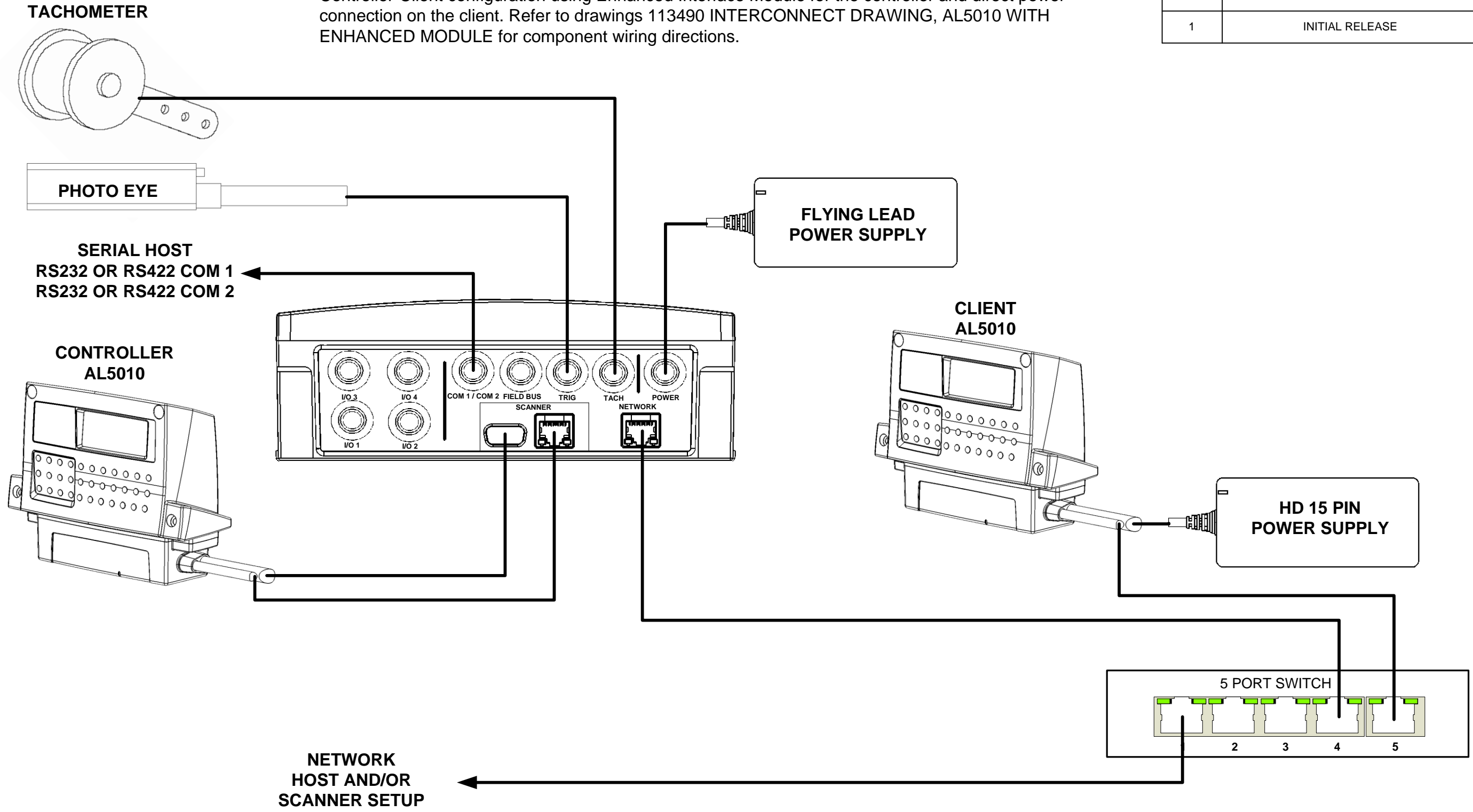

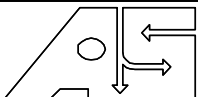
<p>This document is provided for a specific purpose and the disclosed information remains our property. It may not be disclosed, copied, or reproduced, except for specific purpose, without Accu-Sort's prior approval. This notice must appear on any copy or reproduction of this document.</p> <p>©2003, ACCU-SORT SYSTEMS, inc</p>	<p>This is not a controlled copy unless stamped "controlled copy" in red.</p>		 <p>ACCU-SORT SYSTEMS TELFORD, PA. 18969 U S A</p>		
	DRAWN	NRS		DATE	11/23/10
	CHKD	NRS	DATE	11/23/10	<p>INTERCONNECT DRAWING AL5010 CONTROLLER CLIENT</p>
	ENGR	NRS	DATE	11/23/10	
DEPT	APP ENG		DWG NO:	113492	
				SHEET 2 OF 2	

NOTES:

1. REFERENCE DRAWING 111593 CABLE ASSEMBLY AL5010 FOR CABLE BUILD SPECIFICATIONS

REVISIONS			
REV	CHANGES	BY	DATE
1	INITIAL RELEASE	NRS	12/07/10

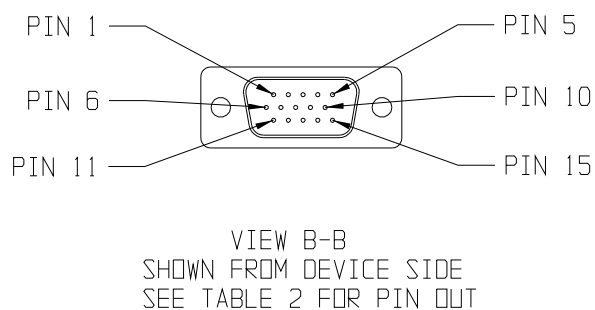
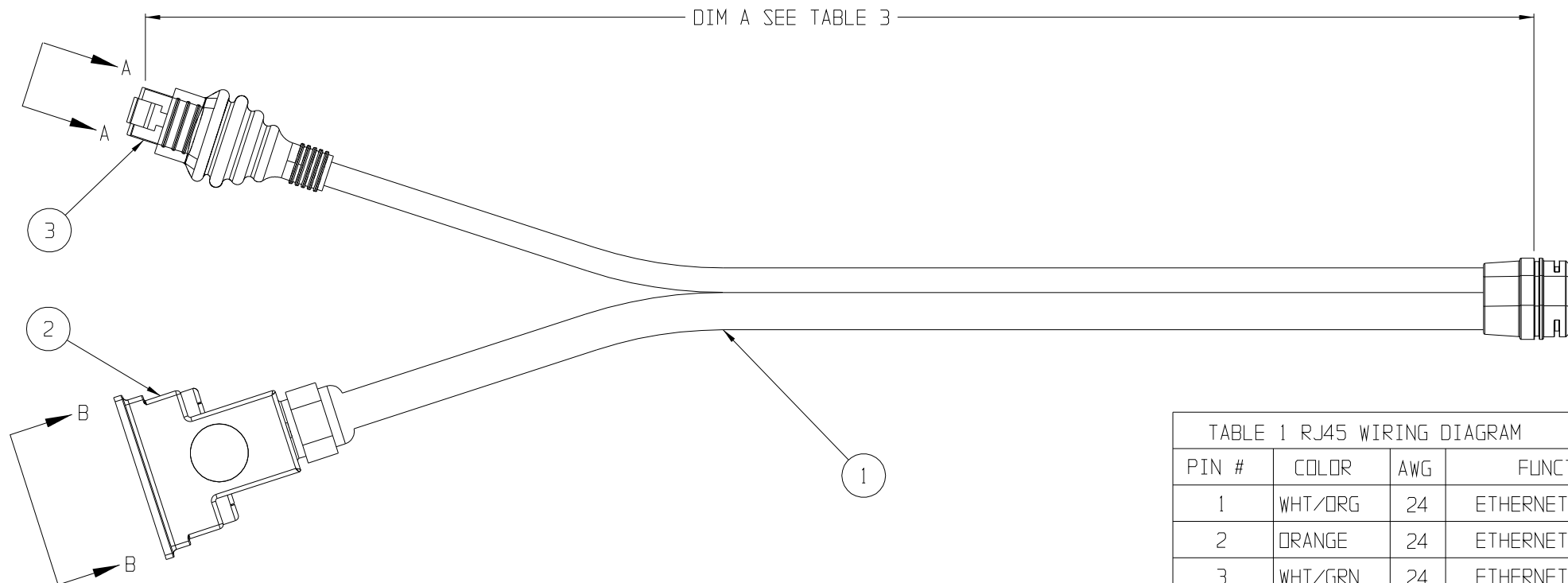
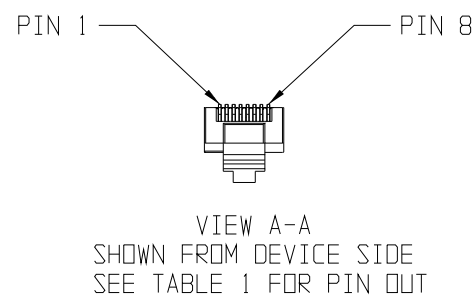

TABLE 1 RJ45 WIRING DIAGRAM

PIN #	COLOR	AWG	FUNCTION
1	WHT/ORG	24	ETHERNET TX + (OUT)
2	ORANGE	24	ETHERNET TX - (OUT)
3	WHT/GRN	24	ETHERNET RX + (IN)
6	GREEN	24	ETHERNET RX - (IN)

TABLE 2 15 PIN MALE D WIRING DIAGRAM

PIN #	COLOR	AWG	FUNCTION
1	WHT/BLU	24	RS 422 TX + (OUT)
2	WHT/BRN	24	RS 422 RX + (IN)
3	WHT/GRY	24	RS 232 TX (OUT)
4	WHT/YEL	24	TACH +
5	WHT/PUR	24	TRIG +
6	BLUE	24	RS 422 TX - (OUT)
7	BROWN	24	RS 422 RX - (IN)
8	GRAY	24	RS 232 RX (IN)
9	YELLOW	24	TACH -
10	PURPLE	24	TRIG -
11	PINK	22	10 - 28V (IN)
12	WHT/BLK	22	GROUND
13	RED	22	10 - 28V (IN)
14	BLACK	22	GROUND
15	DRAIN	20	CHASSIS GROUND

TABLE 3 CABLE PART NUMBERS

ASSEMBLY NO.	DIM A
0111593001	1M (39IN)
0111593002	2.9M (114IN)

TABLE 4 BILL OF MATERIALS

ITEM	QTY	PART NO.	DESCRIPTION
3	1	32-2298UL	RJ 45 MALE PLUG
2	1	1000012241	15 PIN MALE D
1	1	SEE TABLE 3	CABLE ASSEMBLY AL5010

PART NO. SEE TABLE 3

THIS IS NOT A CONTROLLED COPY UNLESS STAMPED "CONTROLLED COPY" IN RED

UNLESS OTHERWISE SPECIFIED:
ALL DIMENSIONS ARE IN INCHES
ALL ANGLES ARE 90°
ALL C-STAKES ARE 90°
ALL BEND RELIEFS TO SUIT

TOLERANCES:
LINEAR: .XX ±.000 ANGULAR: .X ±.01°
XXX ±.000 .XXX ±.01°
FT., IN FRACTIONS ±1/4"

REMOVE SHARP EDGES AND BURRS

DRAWN	NRS	DATE	12/07/10
CHKD		DATE	
ENGR	NRS	DATE	12/07/10
DEPT.	APP ENG		
E-	N/A		
CUSTOMER	N/A		
CONTRACT #	N/A		

ACCU-SORT® SYSTEMS, inc. TELFORD, PA 18969 USA			
CABLE ASSEMBLY, AL5010 PIN OUT			
SIZE D	CAGE CODE 53830	DWG NO.	113493
SCALE	NONE	CAD SYS.	CADKEY
		SHEET	1 OF 1

